

Light Oil Burners



RL 28/2 - 38/2 - 50/2
Low - High Operation

CONTENTS

TECHNICAL DATA	page 3
Burner models	3
Accessories	3
Burner description	4
Packaging - Weight	4
Max. dimensions	4
Standard equipment	4
Firing rate	5
INSTALLATION	6
Boiler plate	6
Blast tube length	6
Securing the burner to the boiler	6
Choice of nozzles for low and high fire	6
Nozzle assembly	7
Combustion head setting	7
Fuel supply	8
Hydraulic connections	8
Pump	9
Burner calibration	10
Final check	11
Burner operation	12
Factory wiring diagram - burner mounted LAL control	13
Field wiring diagram- burner mounted LAL control	14
Factory wiring diagram - remote panel	15
Appendix - Burner firing rates according to air density	16
Siemens LAL control sequence of operations	17
Siemens LAL control troubleshooting guide	18
Start up report	19

N.B.

Figures mentioned in the text are identified as follows:

- 1)(A) = part 1 of figure A, same page as text;
- 1)(A)p.4 = part 1 of figure A, page number 4.

WARNING

Do not store flammable or hazardous materials in the vicinity of fuel burning appliances.

Improper installation, adjustment, alteration, service or maintenance can cause property damage, personal injury or death. Refer to this manual for instructional or additional information. Consult a certified installer, service representative or the gas supplier for further assistance.

Burner shall be installed in accordance with manufacturers requirements as outlined in this manual, local codes and authorities having jurisdiction.

TECHNICAL DATA

MODEL			RL 28	RL 38	RL 38	RL 50
Output ⁽¹⁾ Delivery ⁽¹⁾	High fire	MBtu/hr ⁽³⁾	630 - 1260	896 - 1708	896 - 1708	1120 - 2240
		GPH	4.5 - 9	6.4 - 12.2	6.4 - 12.2	8 - 16
	Low fire	MBtu/hr ⁽³⁾	364 - 630	448 - 896	448 - 896	560 - 1120
		GPH	2.6 - 4.5	3.2 - 6.4	3.2 - 6.4	4 - 8
Fuel			# 2 Fuel oil			
Operation			Low - high			
Nozzles		number	2			
Standard applications			Hot water, steam, thermal oil			
Ambient temperature		°F	32 - 104 (0 - 40 °C)			
Combustion air temperature		°F max	140 (60 °C)			
Main power supply (+/- 10 %)		V/Ph/Hz	120/1/60		208-230 / 460 / 575 / 3 / 60	
Fan motor		rpm	3400		3400	
		W - HP	370 - 0.5		550 - 0.75	
		V	120		208 - 230 / 460 / 575	
		A	5.2		3.2 - 1.6 - 1.3	
Motor capacitor		µF	45			
Ignition transformer		V1 - V2 I1 - I2	120 V - 2 x 5 kV 3.7 A - 35 mA			
Pump delivery (174 PSI) pressure range		GPH PSI	22 60 - 260			
Electrical power consumption		W max	550	600	700	750
Electrical protection			NEMA 1			
Noise levels ⁽²⁾		dBA	68.0	70.0	70.0	75.0

(1) Reference conditions: Ambient temperature 68° F (20° C) - Barometric pressure 394" WC - Altitude 329 ft.

(2) Sound pressure measured in manufacturers combustion laboratory, with burner operating on test boiler and at maximum rated output.

(3) Equivalent Btu values based on 1 USGPH = 140,000 Btu/hr.

Burner models designations

Model	Code	Voltage	Flame safeguard
RL 28	C9511200 (3473270)	120/1/60	Burner mounted
	C9611200 (3473272)	120/1/60	Remote panel
RL 38	C9512200 (3474170)	120/1/60	Burner mounted
	C9612200 (3474172)	120/1/60	Remote panel
	C9512250 (3474370)	208-230/460/3/60	Burner mounted
	C9512251 (3474370)	575/3/60	Burner mounted
	C9612250 (3474372)	208-230/460/3/60	Remote panel
	C9612251 (3474372)	575/3/60	Remote panel
RL 50	C9513200 (3474670)	208-230/460/3/60	Burner mounted
	C9513201 (3474670)	575/3/60	Burner mounted
	C9613200 (3474672)	208-230/460/3/60	Remote panel
	C9613201 (3474672)	575/3/60	Remote panel

ACCESSORIES (optional):

• Kit for lengthening the combustion head

L = Standard length

L1 = Length obtainable with the kit

COD. 3010250 L = 8 1/2" L1 = 13 13/16" • RL 28

COD. 3010251 L = 8 1/2" L1 = 13 13/16" • RL 38

COD. 3010252 L = 8 1/2" L1 = 13 13/16" • RL 50

Important:

The installer is responsible for the supply and installation of any safety device(s) not indicated in this manual.

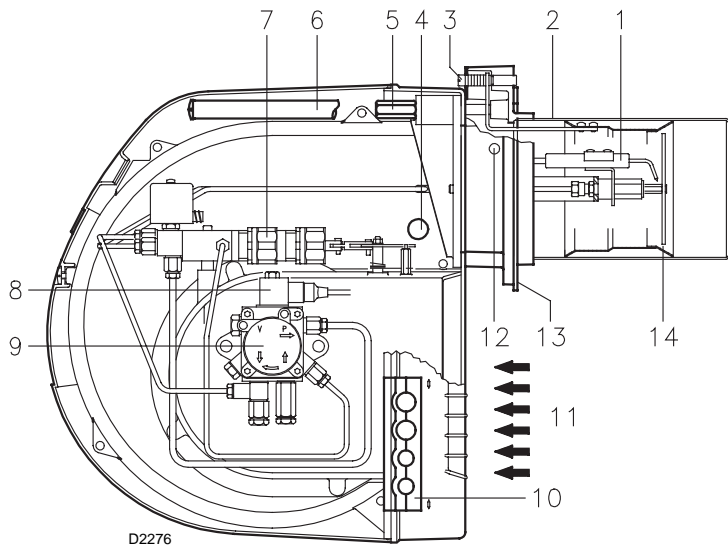

D2276

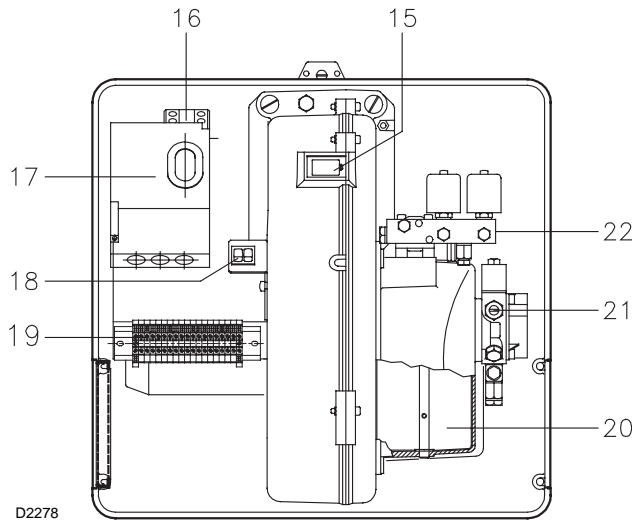

D2278

BURNER DESCRIPTION (A)

- 1 Ignition electrodes
- 2 Combustion head
- 3 Screw for combustion head adjustment
- 4 Photocell for flame monitoring
- 5 Screw for fixing fan to flange
- 6 Slide bars for opening the burner and inspecting the combustion head
- 7 Hydraulic cylinder for regulation of the air damper in low and high fire positions. When the burner is not operating the air damper is fully closed in order to reduce heat dispersion from the boiler due to the flue draught which draws air from the fan suction inlet.
- 8 Safety solenoid valve
- 9 Pump
- 10 Plate prearranged to drill 4 holes for the passage of hoses and electrical cables.
- 11 Air inlet to fan
- 12 Fan pressure test point
- 13 Boiler mounting flange
- 14 Flame stability disk
- 15 Flame inspection window
- 16 Motor contactor
- 17 Flame safeguard control
- 18 Two switches:
 - one "burner off - on"
 - one for "low and high fire operation"
- 19 Burner terminal strip
- 20 Air damper
- 21 Pump pressure adjustment
- 22 Low and high fire valve assembly

Two types of burner failure may occur:

- **FLAME SAFEGUARD LOCK-OUT:**
if the flame relay 17(A) pushbutton lights up, it indicates that the burner is in lock-out.
To reset, press the pushbutton.
- **MOTOR TRIP**
(RL 38 - RL 50 three phase):
release by pressing the pushbutton on thermal overload.

PACKAGING-WEIGHT (B)

Approximate measurements

- The burner is shipped in cardboard box with the maximum dimensions shown in table (B).
- The weight of the burner complete with packaging is indicated in table (B).

MAX. DIMENSIONS (C)

Approximate measurements

The maximum dimensions of the burners are given in (C).

Inspection of the combustion head requires the burner to be opened and the rear part withdrawn on the slide bars.

The maximum dimension of the burner, without casing, when open is give by measurement H.

STANDARD EQUIPMENT

- 2 - Flexible hoses
- 1 - Burner head gasket
- 4 - Screws to secure the burner flange to the boiler:
3/8 W x 1"
- 1 - Instruction booklet
- 1 - Spare parts list
- 1 - Adaptor G 1/8" - 1/8" NPT

(A)

inch	A	B	C	lbs
RL 28	39 ³¹ / ₃₂ "	24 ¹³ / ₁₆ "	19 ¹¹ / ₁₆ "	80
RL 38	39 ³¹ / ₃₂ "	24 ¹³ / ₁₆ "	19 ¹¹ / ₁₆ "	84
RL 50	39 ³¹ / ₃₂ "	24 ¹³ / ₁₆ "	19 ¹¹ / ₁₆ "	86

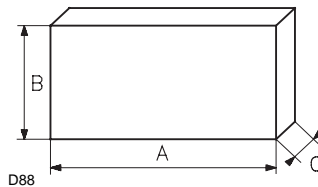

D88

(B)

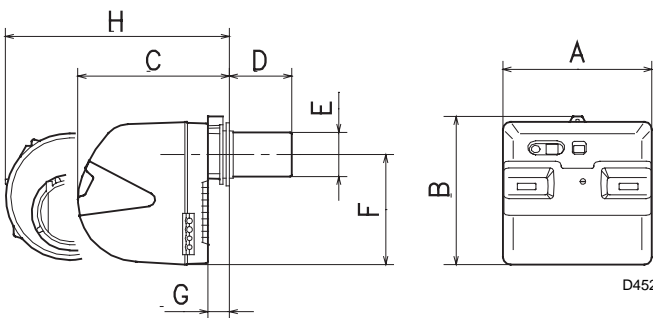

D452

(C)

RL	A	B	C	D ⁽¹⁾	E	F	G	H ⁽¹⁾
28	18 ²³ / ₃₂ "	18 ²¹ / ₃₂ "	18 ¹³ / ₃₂ "	8 ¹ / ₂ " - 13 ¹³ / ₁₆ "	5 ¹ / ₂ "	13 ²⁷ / ₃₂ "	2 ¹ / ₁₆ "	26 ¹⁵ / ₃₂ " - 31 ³ / ₄ "
38	18 ²³ / ₃₂ "	18 ²¹ / ₃₂ "	18 ¹³ / ₃₂ "	8 ¹ / ₂ " - 13 ¹³ / ₁₆ "	5 ¹ / ₂ "	13 ²⁷ / ₃₂ "	2 ¹ / ₁₆ "	26 ¹⁵ / ₃₂ " - 31 ³ / ₄ "
50	18 ²³ / ₃₂ "	18 ²¹ / ₃₂ "	18 ¹³ / ₃₂ "	8 ¹ / ₂ " - 13 ¹³ / ₁₆ "	5 ³ / ₃₂ "	13 ²⁷ / ₃₂ "	2 ¹ / ₁₆ "	26 ¹⁵ / ₃₂ " - 31 ³ / ₄ "

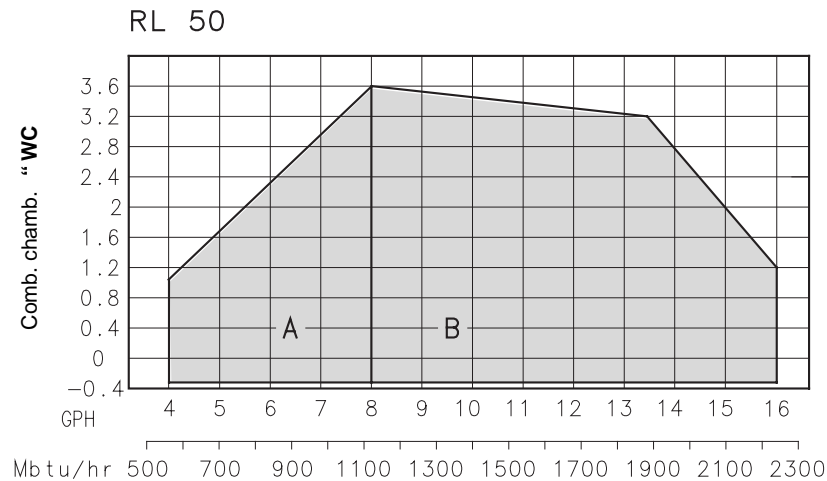
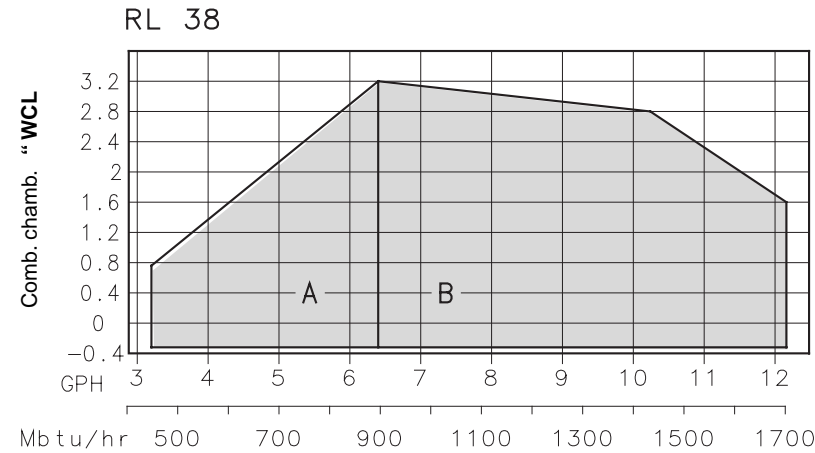
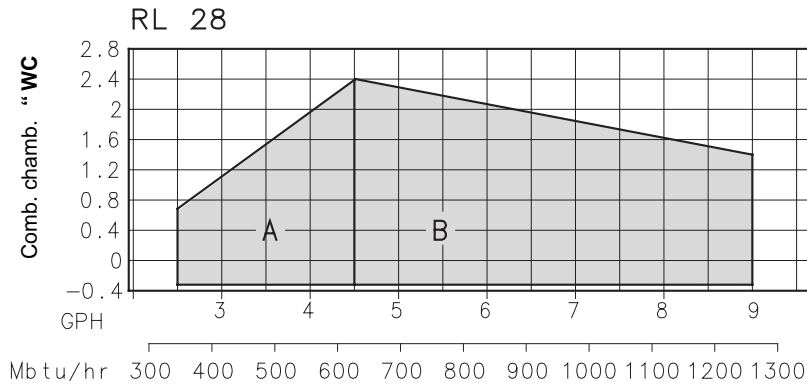

(A) D2279

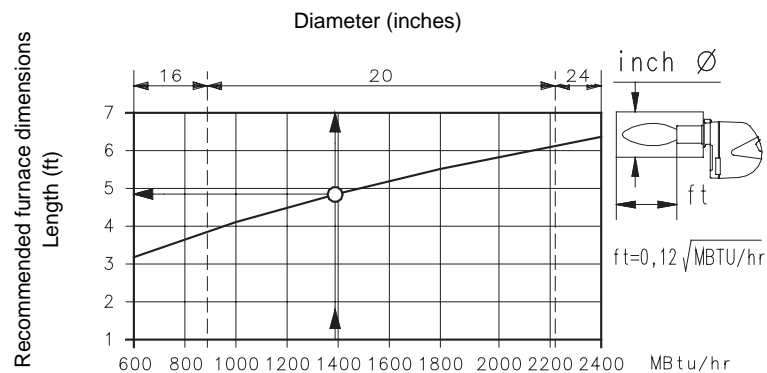

(B) D2918

FIRING RATE (A)

The RL 28 - 38 - 50 Model burners are available in low-high firing configuration.

LOW FIRE DELIVERY must be selected within area A of the adjacent diagrams.

HIGH FIRE DELIVERY must be selected within area B. This area provides the maximum delivery of the burner in relation to the pressure in the combustion chamber.

The firing rate may be found by plotting a vertical line from the desired delivery and a horizontal line from the pressure in the combustion chamber. The intersection of these two lines is the firing rate which must lie within area B.

Important:

the FIRING RATE area values have been obtained considering a surrounding temperature of 68 °F (20 °C), and an atmospheric pressure of 394" WC above sea level and with the combustion head adjusted as shown on page 7.

Note:

The FIRING RATE areas given in figure (A) have been reduced by 10% with respect to the maximum range that can be reached.

Consult Appendix on page 16 for operation at different surrounding temperatures and/or altitudes.

MINIMUM FURNACE DIMENSIONS (B)

The firing rates were set in relation to certified test boilers.

Figure (B) indicates the diameter and length of the test combustion chamber.

Example:

output 1388 MBtu/hr:
diameter 20 inch - length 4.9 ft.

INSTALLATION

inch	A	B	C
RL 28	6 ⁵ / ₁₆ "	8 ¹³ / ₁₆ "	3/8 W
RL 38	6 ⁵ / ₁₆ "	8 ¹³ / ₁₆ "	3/8 W
RL 50	6 ⁵ / ₁₆ "	8 ¹³ / ₁₆ "	3/8 W

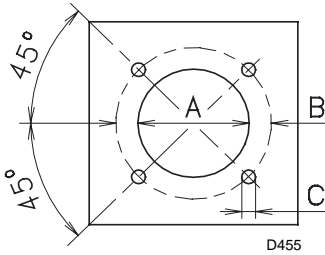

(A)

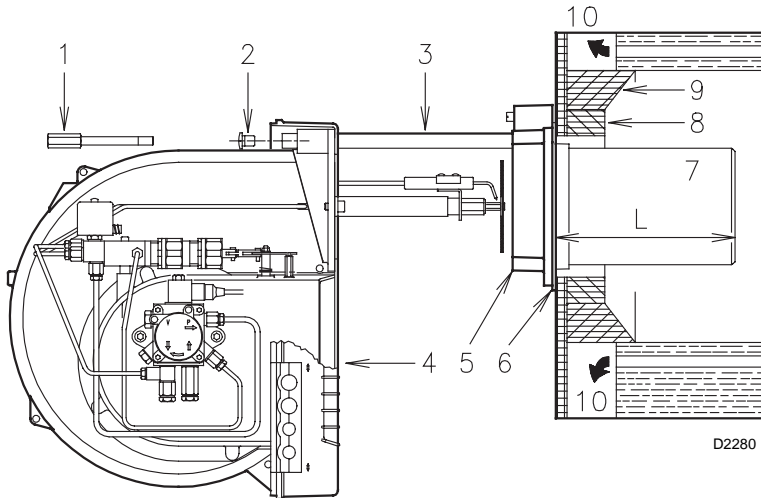

(B)

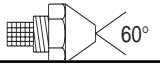
	Nozzle size	GPH			MBtu/hr 174 PSI
		145 PSI	174 PSI	203 PSI	
RL 28	2.00	2.47	2.72	2.95	381
	2.25	2.75	3.04	3.33	428
	2.50	3.07	3.39	3.68	475
	3.00	3.68	4.07	4.42	570
	3.50	4.32	4.74	5.16	664
RL 38	2.50	3.07	3.39	3.68	475
	3.00	3.68	4.07	4.42	570
	3.50	4.32	4.74	5.16	664
	4.00	4.93	5.44	5.89	762
	4.50	5.54	6.12	6.63	857
RL 50	5.00	6.15	6.79	7.36	951
	3.00	3.68	4.07	4.42	570
	3.50	4.32	4.74	5.16	664
	4.00	4.93	5.44	5.89	762
	4.50	5.54	6.12	6.63	857
	5.00	6.15	6.79	7.36	951
	5.50	6.75	7.46	8.10	1044
	6.00	7.40	8.17	8.87	1144

D339

(C)

BOILER PLATE (A)

Drill the combustion chamber mounting plate as shown in (A). The position of the threaded holes can be marked using the burner gasket supplied with the burner.

BLAST TUBE LENGTH (B)

The length of the blast tube must be selected according to the indications provided by the manufacturer of the boiler, and it must be greater than the thickness of the boiler door complete with its insulation. The range of lengths available, L (inch), is as follows:

Blast tube 7):	RL 28	RL 38	RL 50
• short	8 ¹ / ₂ "	8 ¹ / ₂ "	8 ¹ / ₂ "
• long (with the kit)	13 ¹³ / ₁₆ "	13 ¹³ / ₁₆ "	13 ¹³ / ₁₆ "

For boilers with front flue passes (10) or flame inversion chambers, protective insulation material (8) must be inserted between the boiler's refractory (9) and the blast tube (7).

This protective insulation must not compromise the extraction of the blast tube.

For boilers having a water-cooled front, the insulation (8)-(9)(B) is not required unless it is required by the boiler manufacturer.

SECURING THE BURNER TO THE BOILER (B)

Disassemble the blast tube (7) from the burner (4) by proceeding as follows:

- Remove the screws (2) from the two slide bars (3).
- Remove the screw (1) fixing the burner (4) to the flange (5).
- Withdraw the blast tube (7) complete with flange (5) and slide bars (3).

Secure flange (5)(B) to the boiler plate inserting the supplied gasket (6). Use the 4 screws provided after having protected the thread with an anti-seize product (high-temperature grease, compounds, graphite).

The burner-boiler seal must be airtight.

CHOICE OF NOZZLES FOR 1st AND 2nd STAGE

Both nozzles must be chosen from among those listed in Table (C).

The first nozzle determines the delivery of the burner at low fire.

The second nozzle works in combination with the low fire nozzle to determine the delivery of the burner at high fire.

The total deliveries of the low and high fire nozzles must be contained within the value range indicated on page 3.

Use nozzles with a 60° spray angle at the recommended pressure of 174 PSI.

The two nozzles usually have equal deliveries, but the low fire nozzle may have the following specifications if required:

- a delivery less than 50% of the total delivery whenever the back-pressure peak must be reduced at the moment of firing;
- a delivery higher than 50% of the total delivery whenever the combustion during low fire must be improved.

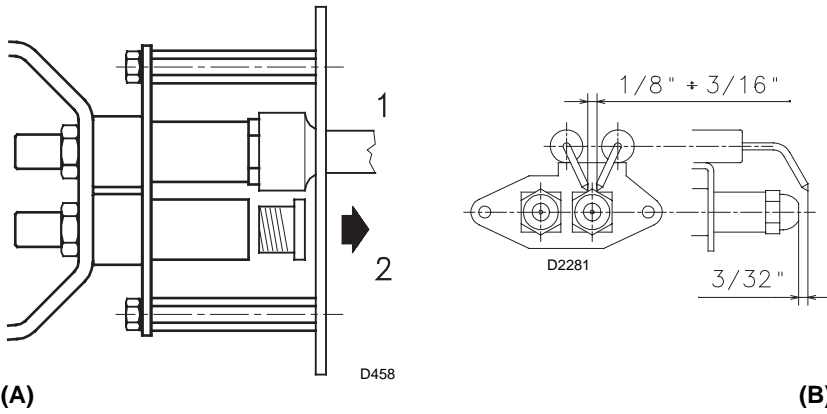

Example with the RL 38 Model

Boiler output = 912 MBTU/hr - efficiency 80 %
 Output required by the burner =
 $912 / 0.8 = 1140 \text{ MBTU/hr}$
 $1140 / 2 = 570 \text{ MBTU/hr per nozzle}$
 therefore, two equal, 60°, 174 PSI nozzles are required:
 $1^\circ = 3.00 \text{ GPH with } 2^\circ = 3.00 \text{ GPH,}$
 or the following two different nozzles:
 $1^\circ = 3.50 \text{ GPH with } 2^\circ = 2.50 \text{ GPH,}$
 or:
 $1^\circ = 2.50 \text{ GPH with } 2^\circ = 3.50 \text{ GPH.}$

NOZZLE ASSEMBLY

At this stage of installation the burner is still disassembled from the blast tube; it is now possible to fit two nozzles, after having removed the plastic plugs 2)(A), inserting the wrench through the central hole in the flame stability disk. Do not use any sealing products such as gaskets, sealing compound, or tape. Be careful to avoid damaging the nozzle sealing seat. The nozzles must be screwed into place tightly but carefully.
 The nozzle for the low fire of operation is the one lying beneath the firing electrodes Fig. (B).

Make sure that the electrodes are positioned as shown in Figure (B).
 Finally remount the burner 4)(C) to the slide bars 3) and slide it up to the flange 5), keeping it slightly raised to prevent the flame stability disk from pressing against the blast tube.

Tighten the screws 2) on the slide bars 3) and screw 1) that attaches the burner to the flange.

If it proves necessary to change a nozzle with the burner already fitted to the boiler, proceed as outlined below:

- Retract the burner on its slide bars as shown in fig. (B)p.6.
- Remove the nuts 1)(D) and the disk 2).
- Use wrench 3)(D) to change the nozzles.

COMBUSTION HEAD SETTING

The setting of the combustion head depends exclusively on the delivery of the burner at high fire - in other words, the combined delivery of the two nozzles selected on page 6. Turn screw 4)(E) until the notch shown in diagram (F) is level with the front surface of flange 5)(E).

Example:

The RL 38 Model with two 3.00 GPH nozzles and 174 PSI pump pressure.
 Find the delivery of the two 3.00 GPH nozzles in table (C), page 6:
 $4 + 4 = 8 \text{ GPH.}$
 Diagram (F) indicates that for a delivery of 8 GPH the RL 38 Model requires the combustion head to be set to approx. three notches, as shown in Figure (E).

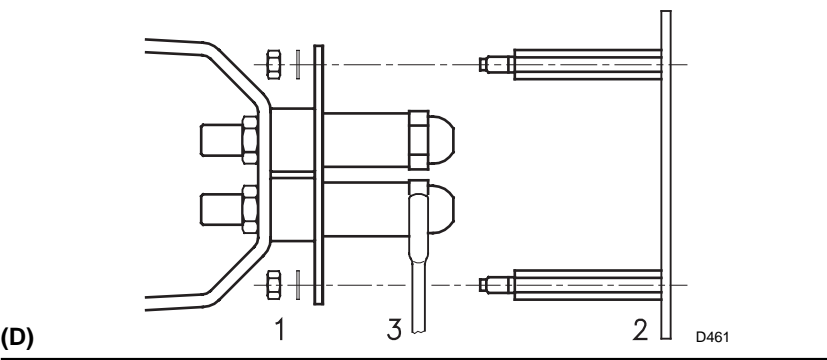
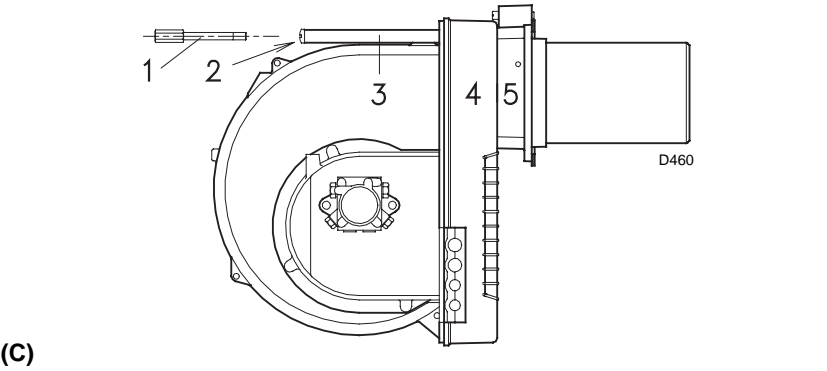

SETTING THE COMBUSTION HEAD

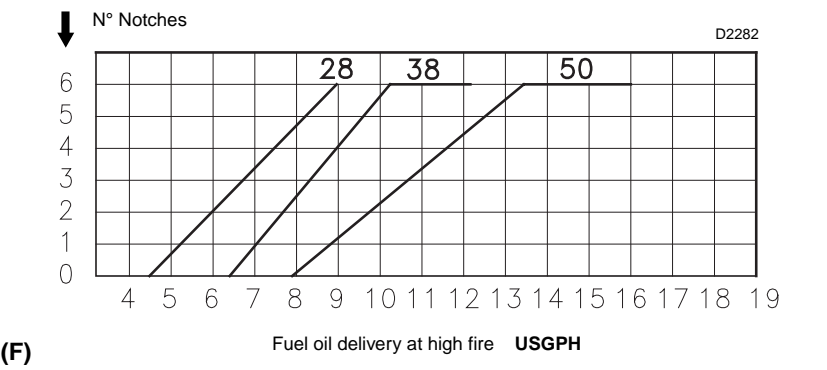
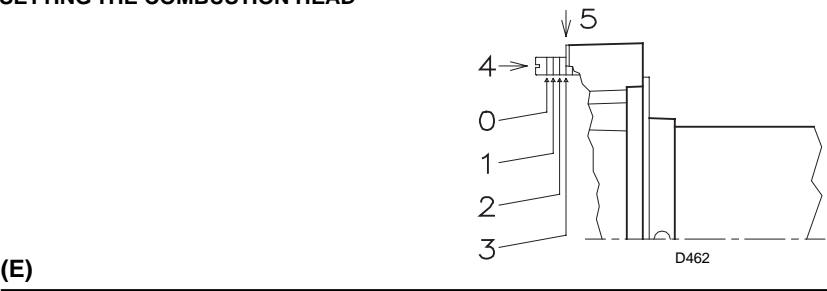

HYDRAULIC SYSTEM

FUEL SUPPLY

DOUBLE - PIPE SYSTEM (A)

The burner is equipped with a self-priming pump which is capable of feeding itself within the limits listed in the table at the left.

The tank higher than the burner **A**

The distance "P" must not exceed 33 ft in order to avoid subjecting the pump's seal to excessive strain; the distance "V" must not exceed 13 ft in order to permit pump self-priming even when the tank is almost completely empty.

The tank lower than the burner **B**

Pump suction values higher than 6.5 PSI must not be exceeded because at higher levels gas is released from the fuel, the pump starts making noise and its working life-span decreases.

It is good practice to ensure that the return and suction lines enter the burner from the same height; in this way it will be more improbable that the suction line fails to prime or stops priming.

LOOP CIRCUIT

A loop circuit consists of a loop of piping supplied from and returning to the tank with an auxiliary pump that circulates the fuel under pressure. A branch connection from the loop goes to feed the burner. This circuit is extremely useful whenever the burner pump does not succeed in self-priming because the tank distance and/or height difference are higher than the values listed in the table.

Key

H = Pump/Foot valve height difference

L = Piping length

Ø = Inside pipe diameter

1 = Burner

2 = Pump

3 = Filter

4 = Manual on/off valve

5 = Suction line

6 = Foot valve

7 = Return line

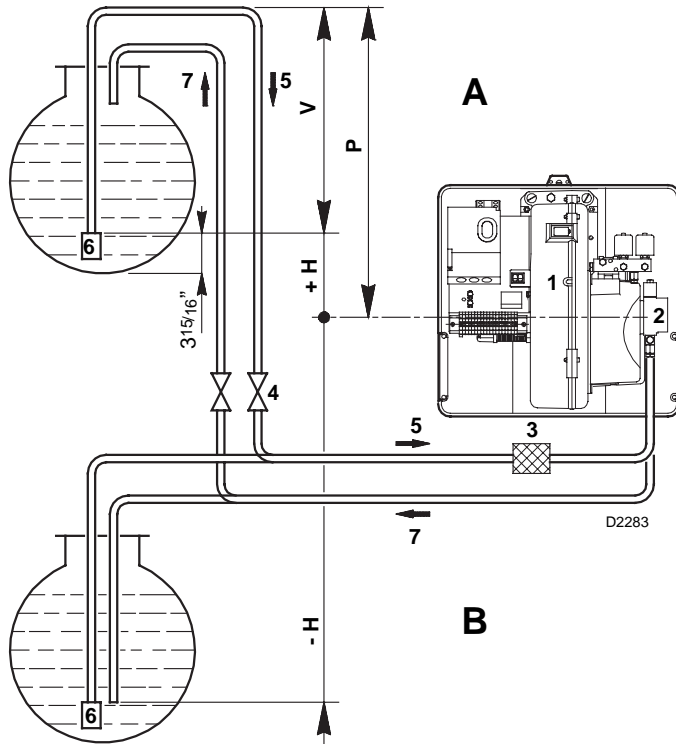

+ H - H (ft)	L (ft)		
	5/16"	3/8"	1/2"
+ 13	115	296	500
+ 10	99	263	500
+ 6.6	86	227	500
+ 3.3	69	194	428
+ 1.6	63	174	391
0	56	158	355
- 1.6	49	141	319
- 3.3	43	122	283
- 6.6	30	89	211
- 10	13	53	138
- 13	-	20	66

(A)

HYDRAULIC CONNECTIONS

HYDRAULIC CONNECTIONS (B)

The pumps is equipped with a by-pass that connects return line and suction line. It is factory set with the by-pass valve closed by screw 6)(A)p.12.

It is therefore necessary to connect both hoses to the pump.

The pump seal will be damaged immediately if it is run with the return line closed and the by-pass screw inserted.

Remove the plugs from the suction and return connections of the pump.

Insert the hose connectors into the connections and screw them down.

Take care that the hoses are not stretched or twisted during installation.

Route the hoses through the holes in the plate, preferably using those on the rh side, fig. (B): unscrew the screws 1), now divide the insert piece into its two parts 2) and 3) and remove the thin section blocking the two passages 4).

Install the hoses where they cannot be stepped on or come into contact with hot surfaces of the boiler.

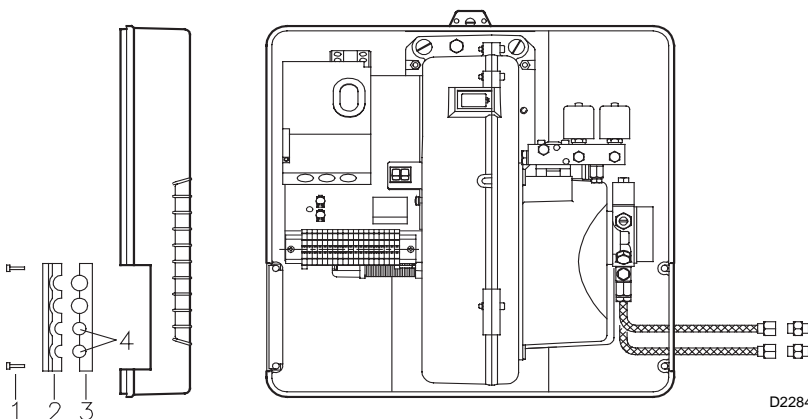

(B)

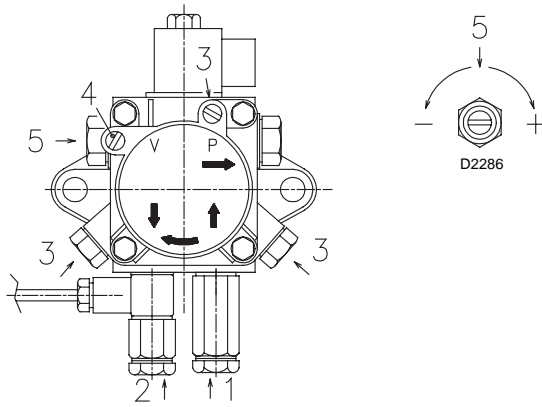

PUMP (A)

- 1 - Suction 1/4" NPT
- 2 - Return 1/4" NPT
- 3 - Pressure gauge attachment G 1/8
- 4 - Vacuum gauge attachment G 1/8
- 5 - Pressure adjustment screw

- A - Min. delivery rate at 174 PSI pressure
- B - Delivery pressure range
- C - Max. suction pressure
- D - Viscosity range
- E - Fuel oil max. temperature
- F - Max. suction and return pressure
- G - Pressure calibration in the factory
- H - Filter mesh width

PUMP PRIMING

- **Before starting the burner, make sure that the tank return line is not clogged. Obstructions in the line could cause the seal located on the pump shaft to break.** (The pump leaves the factory with the by-pass closed).
- In order for self-priming to take place, one of the screws 3)(A) of the pump must be loosened in order to bleed off the air contained in the suction line.
- Start the burner by closing the control circuit and with switch 1)(B)p.10 in the "ON" position. The pump must rotate in the direction of the arrow marked on the cover.
- The pump can be considered to be primed when the fuel oil starts coming out of the screw 3). Stop the burner: switch 1)(B)p.10 set to "OFF" and tighten the screw 3).

The time required for this operation depends upon the diameter and length of the suction tubing. If the pump fails to prime at the first starting of the burner and the burner locks out, wait approx. 15 seconds, reset the burner, and then repeat the starting operation as often as required. After 5 or 6 starting operations allow 2 or 3 minutes for the transformer to cool.

Do not illuminate the photocell or the burner will lock out; the burner should lock out anyway about 10 seconds after it starts.

Important:

the priming operation is possible because the pump is already full of fuel when it leaves the factory. If the pump has been drained, fill it with fuel through the opening on the vacuum gauge connection prior to starting; otherwise, the pump will seize. Whenever the length of the suction piping exceeds 66 - 99 ft, the supply line must be filled using a separate pump.

PUMP		AL 65 C
A	GPH	21.5
B	PSI	58 - 261
C	PSI	6.5
D	cSt	2 - 12
E	°F - °C	140 - 60
F	PSI	29
G	PSI	174
H	inch	0.006

(A)

BURNER CALIBRATION

FIRING

Set switch 1)(B) to "ON".

During the first firing, during the switch over from low to high fire, there is a momentary lowering of the fuel pressure caused by the filling of the high fire nozzle tubing. This lowering of the fuel pressure can cause the burner to lock-out and can sometimes give rise to pulsations.

Once the following adjustments have been made, the firing of the burner must generate a noise similar to the noise generated during operation.

OPERATION

The optimum calibration of the burner requires an analysis of the flue gases at the boiler outlet and adjustments on the following points.

- **Low and high fire nozzles**

See the information listed on page 6.

- **Combustion head**

The adjustment of the combustion head already carried out need not be altered unless the high fire delivery of the burner is changed.

- **Pump pressure**

174 PSI: This is the pressure calibrated in the factory which is usually sufficient for most purposes. Sometimes, this pressure must be adjusted to:

145 PSI in order to reduce fuel delivery. This adjustment is possible only if the ambient temperature remains above 0°C;

203 PSI in order to increase fuel delivery or to ensure firings even at temperatures of less than 0°C.

In order to adjust pump pressure, use the relevant screw 5)(A) page 9.

- **Low fire air damper**

Keep the burner operating at low fire by setting the switch 2)(B) to the low fire. Opening of the air damper 1)(A) must be adjusted in proportion to the selected nozzle: the index 7)(A) must be aligned with the rate specified in table (C). This adjustment is achieved by turning the hex element 4)(A):

- in rh direction (- sign) the opening is reduced;

- in lh direction (+ sign) the opening increases.

Example RL 38 - low fire nozzle 3.00 GPH:

18° notch aligned with index 7)(A).

When the adjustment is done lock the hex element 4) with the ring nut 3).

- **High fire air damper**

Set switch 2)(B) to the high fire position and adjust the air damper 1)(A) by turning the hex element 6)(A), after having loosened the ring nut 5)(A).

Air pressure at attachment 1)(D) must be approximately the same as the pressure specified in table (D) plus the combustion chamber pressure measured at attachment 2). Refer to the example in the adjacent figure.

NOTE:

in order to facilitate adjustment of hex elements 4) and 6)(A), use a 1/8" Allen key 8)(A).

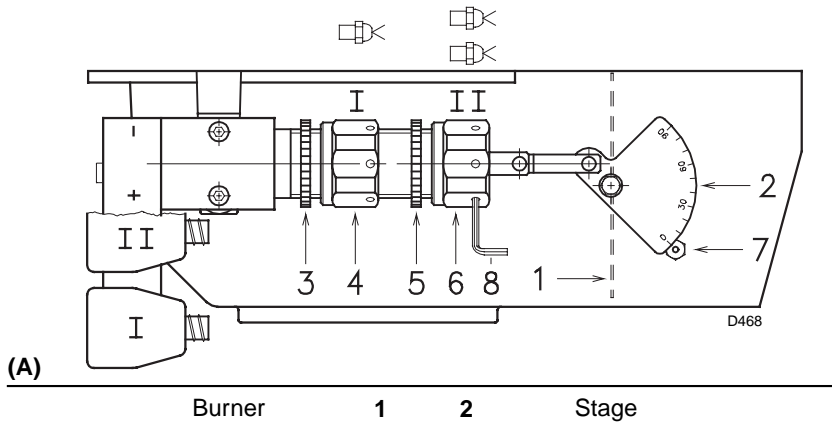

(A)

Burner 1 2 Stage

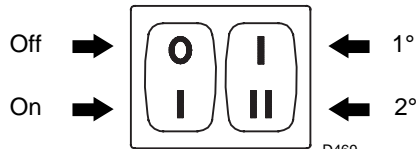

(B)

Low fire

RL 28		RL 38		RL 50	
Nozzle size GPH	α°	Nozzle size GPH	α°	Nozzle size GPH	α°
2.00	14	2.50	12	3.00	12
2.25	17	3.00	18	3.50	15
2.50	20	3.50	20	4.00	18
3.00	22	4.00	22	4.50	21
3.50	24	4.50	23	5.00	23
		5.00	26	5.50	27
				6.00	28

(C)

High fire

RL 28		RL 38		RL 50	
Nozzle size GPH	"WC	Nozzle size GPH	"WC	Nozzle size GPH	"WC
4.50	2.40	6.40	2.70	8.00	2.40
5.10	2.50	7.00	2.70	9.30	2.40
5.80	2.60	7.70	2.70	10.60	2.50
6.40	2.70	8.30	2.70	11.80	2.60
7.00	2.80	9.30	2.70	13.10	2.60
7.70	3.00	10.20	2.70	14.40	3.00
8.30	3.30	11.20	3.10	16.00	4.00
9.00	3.50	12.10	3.70	16.00	3.60

"WC" = air pressure in 1) with zero pressure in 2)

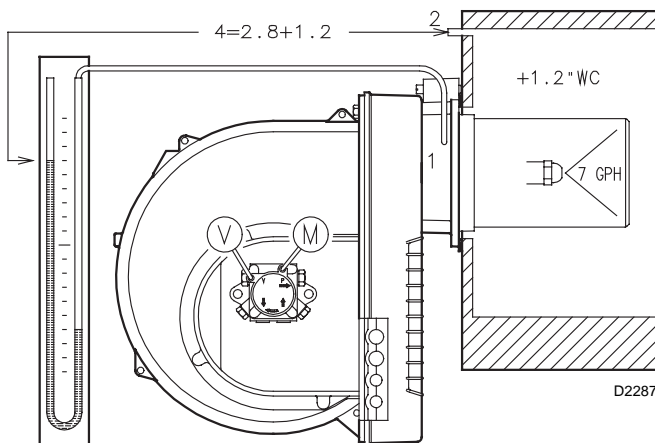

(D)

FINAL CHECKS

- Obscure the photocell and switch on the burner: the burner should start and then lock-out about 5 s after opening of the low fire nozzle valve.
- Illuminate the photocell and reset the burner: the burner should go into lock-out.
- Obscure the photocell while the burner is in high fire operation, the following must occur in sequence: flame extinguished within 1 s, pre-purging for about 20 s, sparking for about 5 s, burner goes into lock-out.
- Switch off operating control while the burner is running: the burner should stop.

MAINTENANCE

Combustion

An analysis of the flue gases at the boiler outlet is required. Significant differences with respect to the previous measurements indicate the points where more care should be exercised during maintenance.

Pump

The pump delivery pressure must be stable at 174 PSI. The suction must be less than 6.5 PSI. Unusual noise must not be evident during pump operation.

If the pressure is found to be unstable or if the pump runs noisily, the flexible hose must be detached from the line filter and the fuel must be sucked from a tank located near the burner. This measure permits the cause of the anomaly to be traced to either the suction line or the pump.

If the problem lies in the suction line, check to make sure that the filter is clean and that air is not entering the piping.

Filters (A)

Check the following filters:

- on line 1) • at nozzle 3), pump 2) and clean or replace as required.

If rust or other impurities are observed inside the pump, use a separate pump to suck out any water and other impurities that may have deposited on the bottom of the tank.

Fan

Check to make sure that no dust has accumulated inside the fan or on its blades, as this condition will cause a reduction in the air flow rate and create incomplete combustion.

Combustion head

Check to make sure that all the parts of the combustion head are in good condition, positioned correctly, free of all impurities, and that no deformation has been caused by operation at high temperatures.

Nozzles

Do not clean the nozzle orifices.

Replace the nozzles every 2-3 years or whenever necessary. Combustion must be checked after the nozzles have been changed.

Photocell (cad cell) (B)

Clean the glass cover from any dust that may have accumulated. Photocell 1) can be removed by pulling it outward forcefully.

Flame inspection window (C)

Clean the glass.

Flexible hoses

Check to make sure that the flexible hoses are still in good condition.

Boiler

Clean the boiler as indicated in its accompanying instructions in order to maintain all the original combustion characteristics intact, especially the flue gas temperature and combustion chamber pressure. Lastly, check the condition of the flue gas stack.

TO OPEN THE BURNER (D)

- Switch off the electrical power.
- Loosen screws 1) and withdraw the cover 2).
- Unscrew screws 3).
- Fit the two extensions 4) supplied with the burner onto the slide bars 5) (model with long blast tube, obtainable with the kit).
- Pull part A backward keeping it slightly raised to avoid damaging the disk 6) on blast tube 7).

FUEL PUMP AND/OR COUPLINGS REPLACEMENT (E)

See fig. (E). Dimension X should be set as follows:

RL28 - 1/4"

RL38 - 5/32"

RL50 - 5/32"

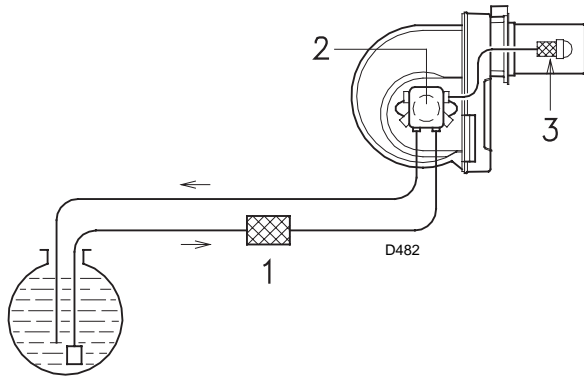

(A)

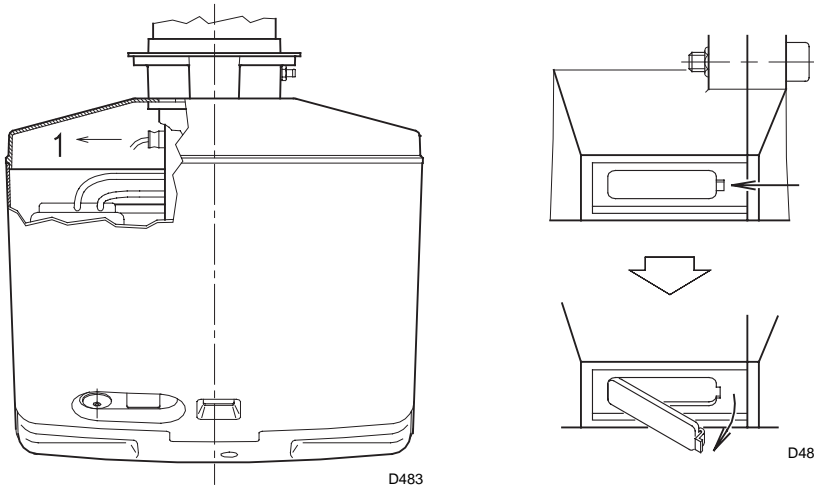

(B)

(C)

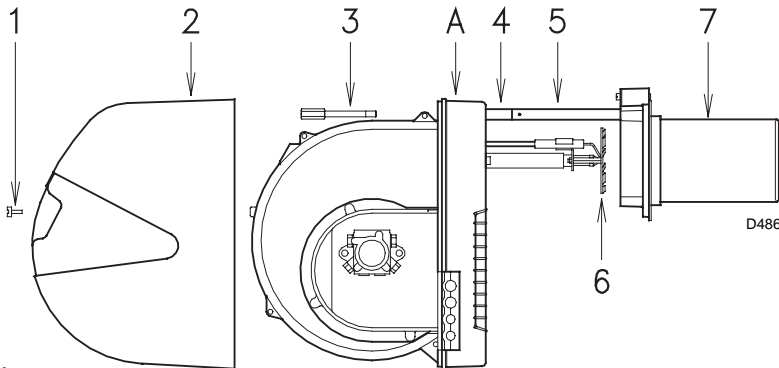

(D)

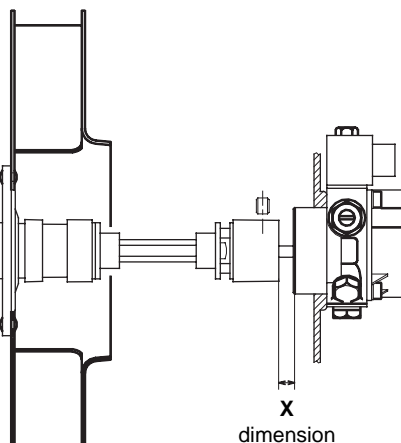

(E)

D2854

BURNER OPERATION

BURNER STARTING (A)

Operating control closes.

The motor starts and the ignition transformer is connected.

The pump 3) sucks the fuel from the tank through the piping 1) and the filter 2) and pumps it under pressure for delivery. The piston 4) rises and the fuel returns to the tank through the piping 5) - 7). The screw 6) closes the by-pass to the suction side of the pump and the solenoid valves 8) - 11) - 16), de-energized, close the flow to the nozzles.

The hydraulic cylinder 15), piston A, opens the air damper: pre-purging begins with the low fire air delivery.

At the opening of the solenoid valves 8) and 16) the fuel passes through the piping 9) and filter 10) and is then sprayed out through the nozzle, igniting when it comes into contact with the spark. This is the low fire flame.

If the high fire control device is closed, the solenoid valve 11) is opened and the fuel enters the valve 12) and raises the piston which opens two passages: one to piping 13), filter 14), and the high fire nozzle, and the other to the cylinder 15), piston B, that opens the fan air damper for high fire.

FIRING FAILURE

If the burner does not fire, it goes into lock-out within 5 s of the opening of the low fire solenoid valve.

The flame safeguard indicator light will light up.

LOCKOUT DURING OPERATION

If the flame goes out during operation, the burner shuts down automatically within 1 second and automatically attempts to start again by repeating the starting cycle.

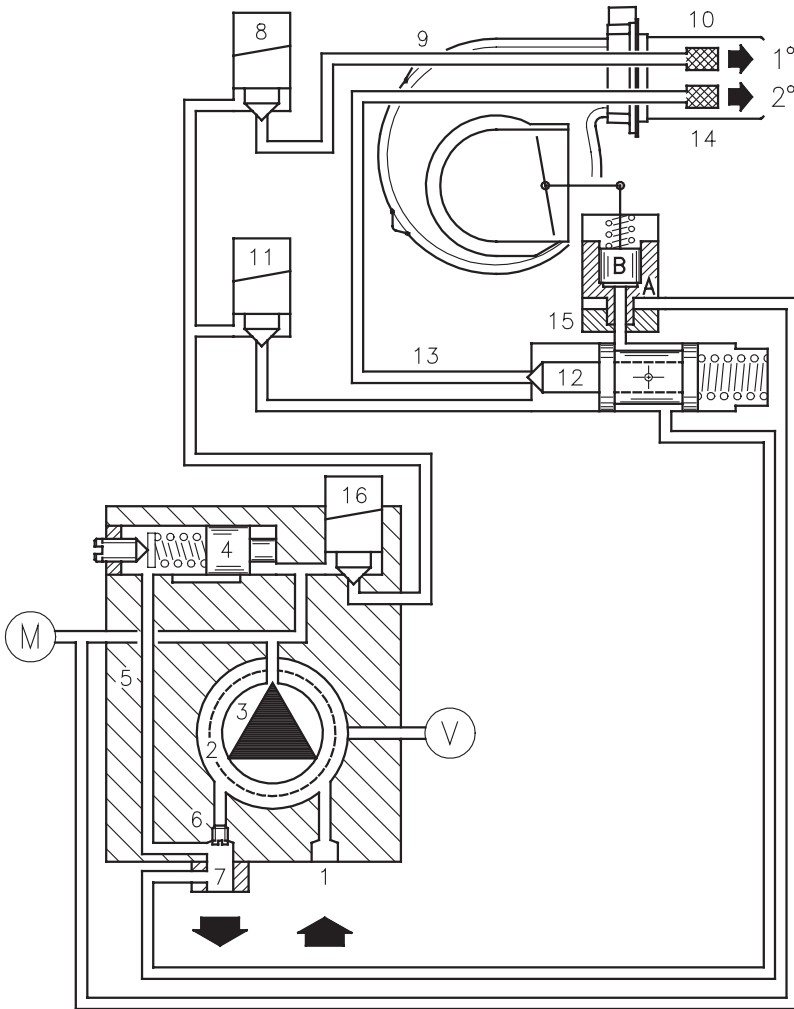

D2288

(A)

Factory Wiring Diagram

RL 28 - 38 single phase with burner mounted Siemens LAL control

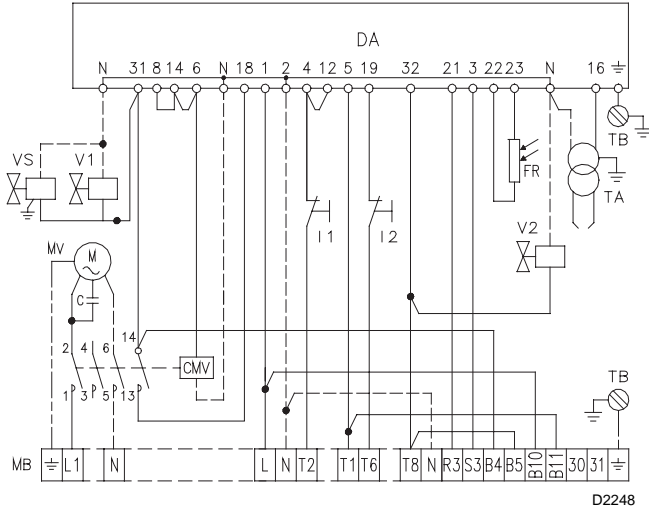

Continuous fan operation

Change the wire connection from terminal 6 to terminal 1 of control box.

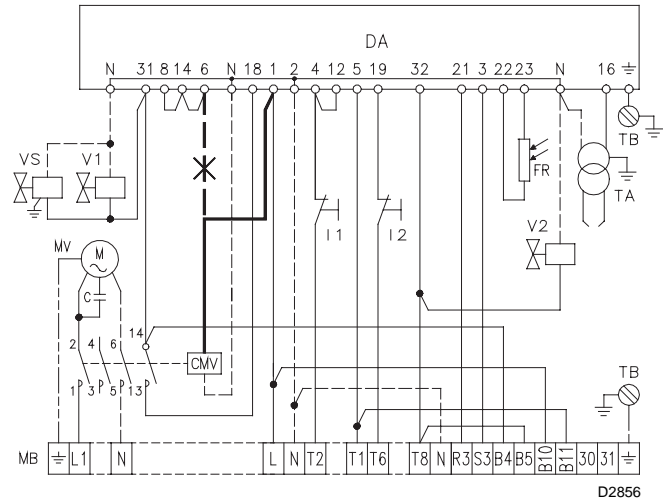

(A)

RL 38 - 50 three phase with burner mounted Siemens LAL control

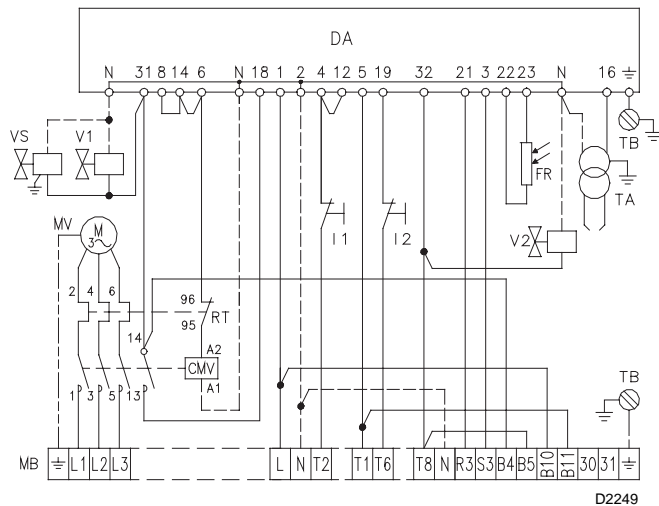

Continuous fan operation

Change the wire connection from terminal 6 to terminal 1 of control box.

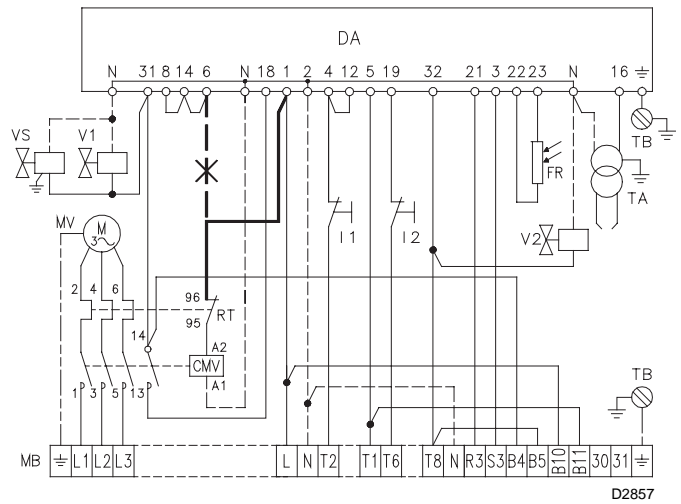

(B)

LAYOUT (A)

Burners RL 28 (single-phase)

The flame safeguard mounted on the burner.

LAYOUT (B)

Burners RL 38-50 (three-phase)

The flame safeguard mounted on the burner.

- Models RL 38 - RL 50 three phase leave the factory preset for **208-230 V** power supply.
- If **460 V** power supply is used, change the motor connection from delta to star and change the setting of the thermal cut-out as well.

Key to Layouts (A) - (B)

C	- Capacitor
CMV	- Motor contactor
DA	- Control box
MB	- Burner terminal strip
FR	- Photocell
I1	- Switch: burner off - on
I2	- Switch: low and high fire operation
MV	- Fan motor
TA	- Ignition transformer
TB	- Burner ground (earth) connection
V1	- Low fire solenoid valve
V2	- High fire solenoid valve
VS	- Safety solenoid valve
RT	- Thermal overload

Field Wiring Diagram

RL 28 - 38 single-phase burner with burner mounted LAL flame safeguard

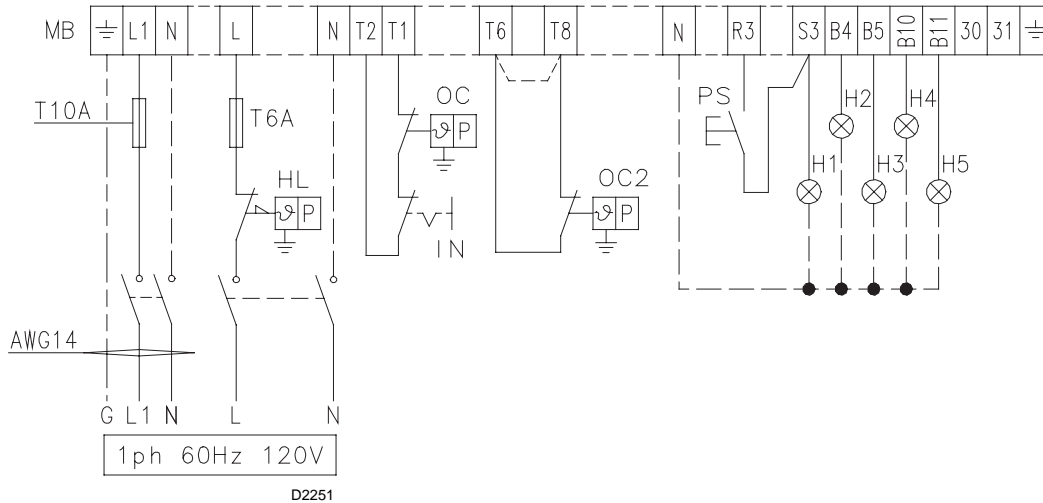

(A)

RL 38 - 50 three-phase burner with burner mounted LAL flame safeguard

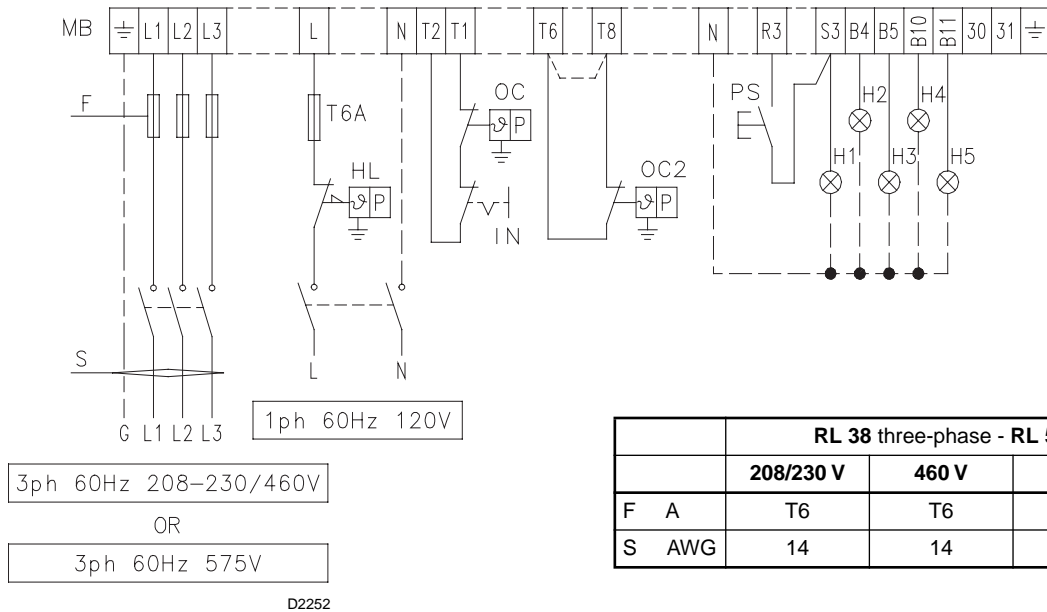

RL 38 three-phase - RL 50				
		208/230 V	460 V	575 V
F	A	T6	T6	T4
S	AWG	14	14	14

(A)

FIELD WIRING CONNECTIONS

As set by installer

Use flexible cables according to local regulation.

LAYOUT (A)

The RL 28 - 38 Models field connections single-phase 120 V power supply.

LAYOUT (B)

The RL 38 - 50 Models field connections three-phase 208-230/460 V power supply.

Key to wiring layouts (A) - (B)

- MB - Burner terminal strip
- PS - Remote lock-out reset
- H1 - Remote lock-out signal
- H2 - Low fire signal
- H3 - High fire signal
- H4 - Power on signal
- H5 - Limit satisfied
- IN - Manual burner stop switch
- OC - Operating control.
- OC2 - High-low control.
- HL - High limit control.

Important:

The burner is factory set for low - high operation and it must be connected to the OC2 control device to control fuel oil valve V2. If on - off operation is required, instead of control device OC2 install a jumper lead between terminals T6 and T8 of burner terminal strip.

NOTE

- The setting of the thermal overload must be according to the total burner amperage draw.
- Burners RL 38 three-phase and RL 50 leave the factory preset for **208-230 V** power supply. If **460 V** power supply is used, change the motor connection from delta to star and change the setting of the thermal overload.
- The RL 28 - 38 - 50 burners have been type-approved for intermittent operation. This means they should compulsorily be stopped at least once every 24 hours to enable the control box to perform self checks at start-up. Burner halts are normally provided for automatically by the boiler load control system.

Factory Wiring Diagram

RL 28 - 38 single phase with remote control panel

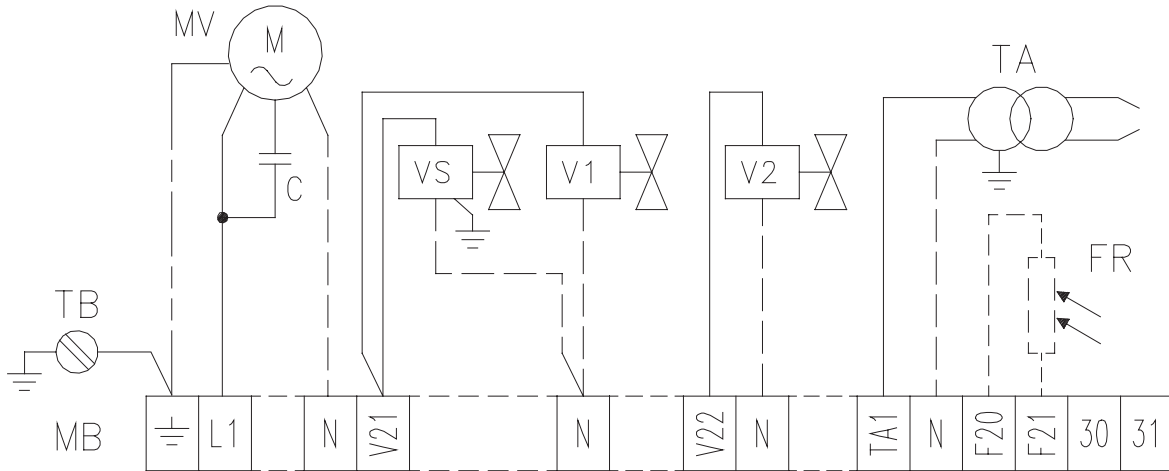

D2356

(A)

RL 38 - 50 single phase with remote control panel

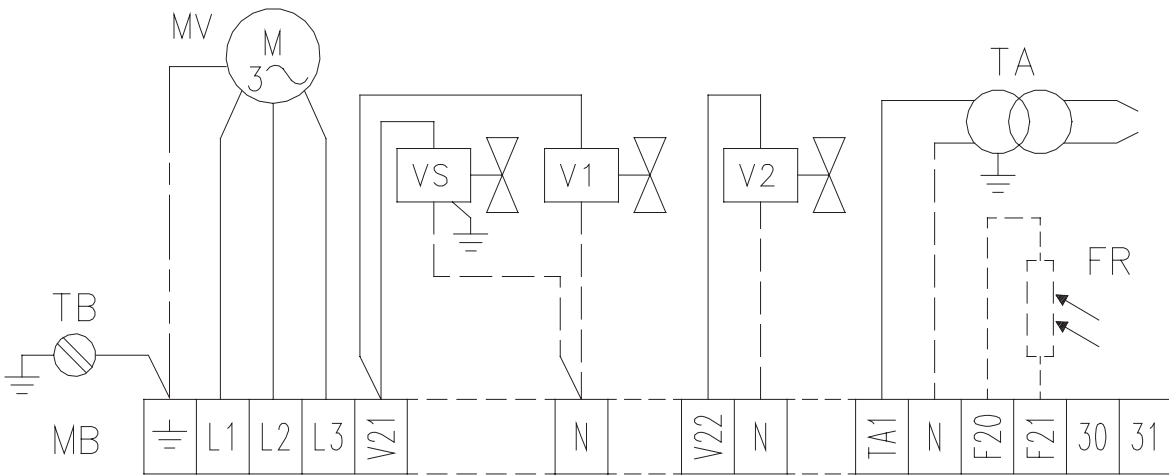

D2357

(B)

LAYOUT (A)

Burners RL 28-38 (single-phase)

See the internal electrical systems of the remote panel in order to have the complete wiring diagram.

LAYOUT (B)

Burners RL 38-50 (three-phase)

For remote panel configurations

See the internal electrical systems of the remote panel in order to have the complete wiring diagram.

Key to Layouts (A) - (B)

- C - Capacitor
- CMV - Motor contactor
- DA - Control box
- MB - Burner terminal strip
- FR - Photocell
- I1 - Switch: burner off - on
- I2 - Switch: low and high fire operation
- MV - Fan motor
- TA - Ignition transformer
- TB - Burner ground (earth) connection
- V1 - Low fire solenoid valve
- V2 - High fire solenoid valve
- VS - Safety solenoid valve
- RT - Thermal overload

APPENDIX - Burner firing rates according to air density

above sea level		average barom. pressure		CORRECTION FACTOR F								
				Air temperature °F (°C)								
ft	m	" W.C.	mbar	0 (0°C)	41 (5°C)	50 (10°C)	59 (15°C)	68 (20°C)	77 (25°C)	86 (30°C)	104 (40°F)	
0	0	399	1013	1,087	1,068	1,049	1,031	1,013	0,996	0,980	0,948	
329	100	394	1000	1,073	1,054	1,035	1,017	1,000	0,983	0,967	0,936	
658	200	389	989	1,061	1,042	1,024	1,006	0,989	0,972	0,956	0,926	
987	300	385	978	1,050	1,031	1,013	0,995	0,978	0,962	0,946	0,916	
1316	400	380	966	1,037	1,018	1,000	0,983	0,966	0,950	0,934	0,904	
1645	500	376	955	1,025	1,007	0,989	0,972	0,955	0,939	0,923	0,894	
1974	600	372	944	1,013	0,995	0,977	0,960	0,944	0,928	0,913	0,884	
2303	700	367	932	1,000	0,982	0,965	0,948	0,932	0,916	0,901	0,872	
2632	800	363	921	0,988	0,971	0,954	0,937	0,921	0,906	0,891	0,862	
2961	900	358	910	0,977	0,959	0,942	0,926	0,910	0,895	0,880	0,852	
3290	1000	354	898	0,964	0,946	0,930	0,914	0,898	0,883	0,868	0,841	
3947	1200	346	878	0,942	0,925	0,909	0,893	0,878	0,863	0,849	0,822	
4605	1400	337	856	0,919	0,902	0,886	0,871	0,856	0,842	0,828	0,801	
5263	1600	329	836	0,897	0,881	0,866	0,851	0,836	0,822	0,808	0,783	
5921	1800	321	815	0,875	0,859	0,844	0,829	0,815	0,801	0,788	0,763	
6579	2000	313	794	0,852	0,837	0,822	0,808	0,794	0,781	0,768	0,743	

(A)

The FIRING RATE area values have been obtained considering a surrounding temperature of 68°F (20°C), and an atmospheric pressure of 398" W.C. and with the combustion head adjusted as shown on page 7.

The burner may be required to operate with combustion air at a higher temperature and/or at higher altitudes.

Heating of air and increase in altitude produce the same effect: the expansion of the air volume, i.e. the reduction of air density.

The burner fan's delivery remains substantially the same, but the oxygen content per cubic meter and the fan's head are reduced.

It is therefore important to know if the maximum output required of the burner at a given combustion chamber pressure remains within the burner's firing rate range even at different temperature and altitude conditions. Proceed as follows to check the above:

- 1 - Find the correction factor F in the Table (A) for the plant's air temperature and altitude.
- 2 - Divide the burner's delivery Q by F in order to obtain the equivalent delivery Q_e:

$$Q_e = Q : F \quad (\text{MBtu/hr})$$

- 3 - In the firing rate range of the burner, Fig. (B), indicate the work point defined by:

Q_e = equivalent delivery

H₁ = combustion chamber pressure

The resulting point A must remain within the firing rate range.

- 4 - Plot a vertical line from Point A as shown in Figure (B) and find the maximum pressure H₂ of the firing rate.
- 5 - Multiply H₂ by F to obtain the maximum reduced pressure H₃ of the firing rate.

$$H_3 = H_2 \times F \quad (\text{" W.C.})$$

If H₃ is greater than H₁, as shown in Fig. (B), the burner delivers the output required.

If H₃ is lower than H₁, the burner's delivery must be reduced. A reduction in delivery is accompanied by a reduction of the pressure in the combustion chamber:

Q_r = reduced delivery

H_{1r} = reduced pressure

$$H_{1r} = H_1 \times \left(\frac{Q_r}{Q} \right)^2$$

Example, a 5% delivery reduction:

$$Q_r = Q \times 0.95$$

$$H_{1r} = H_1 \times (0.95)^2$$

Steps 2 - 5 must now be repeated using the new Q_r and H_{1r} values.

Important: the combustion head must be adjusted in respect to the equivalent delivery Q_e.

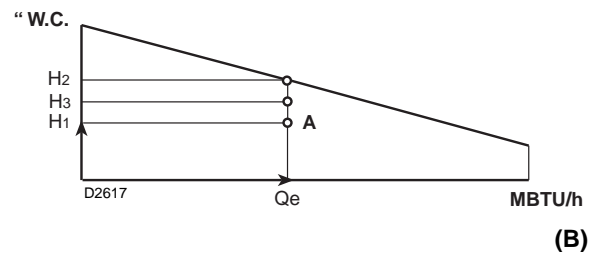

(B)

Low-High

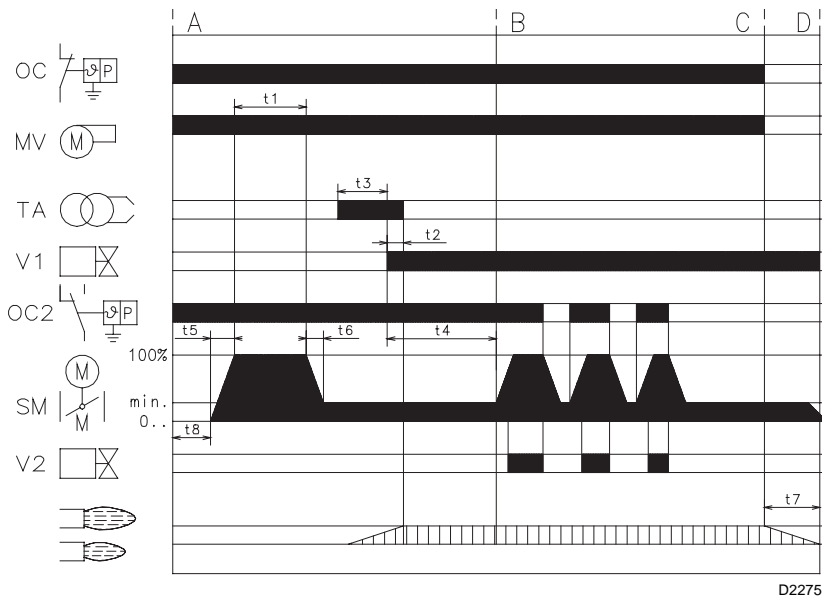

OPERATION LAYOUT

Switching times are given in seconds, in the burner startup sequence.

LAL 2.25

t1	18	t5	optional
t2	4	t6	optional
t3	2	t7	12
t4	12	t8	4

Legend for the times

- t1** Pre-purge time with air damper open.
- t2** Safety time.
- t3** Pre-ignition time, short ("Z" connected to terminal "16").
- t4** Interval between voltage at terminals "18" and "20"
- t5** Air damper running time to OPEN position.
- t6** Air damper running time to low-flame position (MIN).
- t7** Permissible after-burn time.
- t8** Interval to the OPEN command for the air damper.

(A)

BURNER FAULT INDICATIONS

Control program fault conditions and lock-out indication

Whenever a fault occurs, the sequence switch stops and with it the lock-out indicator.
The symbol above the reading mark of the indicator gives the type of fault:

◀	No start	One of the contacts has not closed	The contact of the limit thermostat or any other switching devices in the control loop of terminal 4 to terminal 5 are opened.
		Extraneous light	Lock-out during or after completion of the control program Examples: – Flame not extinguished – Leaking fuel valves – Faulty flame supervision circuit
▲	Interruption of startup sequence	Terminals 6, 7 and 15 remain under voltage until fault has been corrected	
■	Lock-out		Defect in the flame supervision circuit, faulty flame signal, extraneous light
▼	Interruption of startup sequence		Terminals 6, 7 and 15 remain under voltage until fault has been corrected
1	Lock-out		No flame signal is present on completion of the safety time
I	Lock-out		Flame signal has been lost during operation

BURNER START UP REPORT

Model number: _____	Serial number: _____
Project name: _____	Start-up date: _____
Installing contractor: _____	Phone number: _____

GAS OPERATION			
Gas Supply Pressure: _____	CO ₂ : Low Fire _____	High Fire _____	_____
Main Power Supply: _____	O ₂ : Low Fire _____	High Fire _____	_____
Control Power Supply: _____	CO: Low Fire _____	High Fire _____	_____
Burner Firing Rate: _____	NO _x : Low Fire _____	High Fire _____	_____
Manifold Pressure: _____	Net Stack Temp - Low Fire: _____	High Fire: _____	_____
Pilot Flame Signal: _____	Comb. Efficiency - Low Fire: _____	High Fire: _____	_____
Low Fire Flame Signal: _____	Overfire Draft: _____		_____
High Fire Flame Signal: _____			_____

OIL OPERATION			
Oil supply pressure: _____	CO ₂ : Low Fire _____	High Fire _____	_____
Oil suction pressure: _____	O ₂ : Low Fire _____	High Fire _____	_____
Control Power Supply: _____	CO: Low Fire _____	High Fire _____	_____
Burner Firing Rate: _____	NO _x : Low Fire _____	High Fire _____	_____
Low Fire Flame Signal: _____	Net Stack Temp - Low Fire: _____	High Fire: _____	_____
High Fire Flame Signal: _____	Comb. Efficiency - Low Fire: _____	High Fire: _____	_____
Low Fire Nozzle Size: _____	Overfire Draft: _____		_____
High Fire Nozzle Size: _____	Smoke number: _____		_____

CONTROL SETTINGS			
Operating Setpoint: _____	Low Oil Pressure: _____	_____	_____
High Limit Setpoint: _____	High Oil Pressure: _____	_____	_____
Low Gas Pressure: _____	Flame Safeguard Model Number: _____	_____	_____
High Gas Pressure: _____	Modulating Signal Type: _____	_____	_____

NOTES	<hr/> <hr/> <hr/> <hr/> <hr/> <hr/> <hr/> <hr/>
--------------	-------------------------------------------------



Represented By:

Power Equipment Company

2011 Williamsburg Road

Richmond, VA 23231

Ph: 804-236-3800

Fx: 804-236-3882

www.peconet.com