

The logo for ISTEC, featuring the letters 'I', 'S', 'T', 'E', and 'C' in a bold, blue, sans-serif font. The letters are slightly slanted to the right. The background of the entire page is a close-up, high-angle shot of water splashing, creating a dynamic and textured appearance with various shades of white, light blue, and yellowish-brown.

Flow Measurement & Control

BTU Meters

Flow Meters

Remote Displays

Radiator Valves

Balancing Valves

Flow Measurement & Control Solutions

TABLE OF CONTENTS

BTU Meters – 4000 Series.....	3
Chip Card System – 5000 Series	4
Super Jet Water Meters – 1700 Series.....	5
Super Jet Water Meters – 1800 Series.....	6
Irrigation Meters – 1900 Series	7
Oil Meters – 9200 Series	8
Vortex Shedding Flow Meters – 2150 & 7150 Series	9
Electromagnetic Meters – 6000 Series	10
Remote Displays – 9500 Series	11
Balancing Valves – 2900 Series	12
Radiator Valves – 2000 Series	13
Water Meter Specifications.....	15

Mission Statement

To provide our customers with products of unsurpassed quality, superior support and innovative solutions to their flow measurement and control applications.

To respond to our customers' needs in a timely and professional manner.

To foster an ongoing relationship with our customers, suppliers and industry colleagues.

BTU METERS

4000 Series

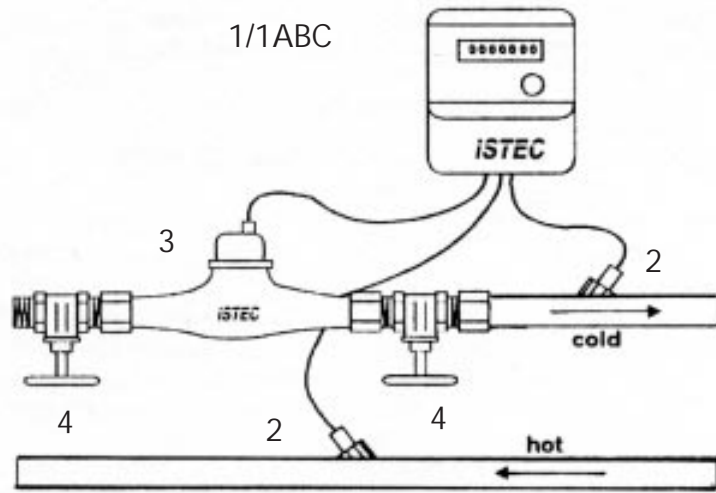

Applications

- Heating Systems
- Cooling systems
- District Heating/Cooling systems
- Cogeneration Systems
- Solar Systems
- Efficiency Measuring/Verification
- Geothermal systems
- Heat Reclaimers

Product Overview

ISTEC's BTU Meters measure the total energy used or transferred in a liquid system. BTU's are calculated by multiplying the temperature difference (ΔT) between the supply and return lines by the flow rate (gpm) through these lines.

$$\text{BTU} = \Delta T \times \text{Flow}$$

The illustration above shows a typical system:

1. Calculating Unit with Power Supply
2. Wells for supply & return
3. Flow Meter with Pulse
4. Stop Valves (recommended)

Technical Specifications

Minimum Temperature of Liquid	32°F
Maximum Temperature of Liquid	250°F
Minimum ΔT (temp. difference)	2°F
Maximum ΔT (temp. difference)	180°F
Ambient Temperature	14°F - 250°F
Temperature Sensor Resistance:	500 Ω @ 32°F 700 Ω @ 212°F

How to Order

- 1) BTU Calculating Unit:
 - 10' Probe - # 4001
 - 15' Probe - # 4002
 - 30' Probe - # 4003
- 1A) Power Supply:
 - 24VAC Converter - # 4010
 - Transformer (110 to 24 VAC) - #4018
 - 1 Year Battery - # 4011
 - 6 Year Battery - #4016
- 2) Temperature Sensor Wells – 3/8" NPT
 - Short - # 4020 (for pipe sizes up to 1-1/2")
 - Long - # 4022 (for pipe sizes 2" and up)
- 3) Flow Meter with Pulse (see pages 5 & 6)

Options

- 1B) Pulse Output Module - # 4072
- 1C) Pulse/4-20mA Output Module - # 4075

Dimensions

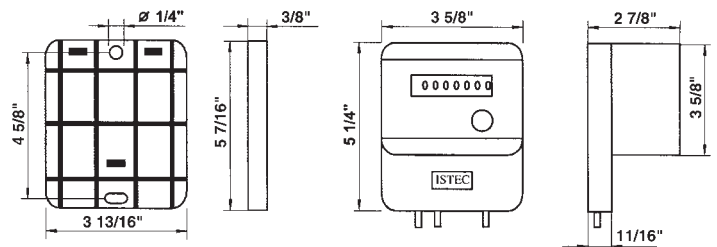

CHIP CARD SYSTEM

5000 Series



Applications

- Hot/Cold Water Meters
- BTU Meters
- Gas Meters
- Oil Meters
- Steam Meters
- Electric Meters

Product Overview

ISTEC's Chip Card System is used to measure and read Water Consumption, Energy Consumption in Heating and Cooling systems; or any other metering system with a pulse output.

The use of the Chip Card System virtually eliminates the error in the transcription process. It is a very simple and accurate way of transferring information from multiple meters to your computer.

Components

Chip Card is a credit card sized "smart card" equipped with a microprocessor module. A single card can store data from up to 50 meters.

Chip Card Reader transfers data from the Chip Card into your computer.

Smart Water Meter is a Water Meter (Hot or Cold) with a Liquid Crystal Display and a Chip Card Port. The Water Meter measures the flow and displays the total on the 6-Digit Liquid Crystal Display.

Smart BTU Meter is similar to the Smart Water Meter with the addition of platinum sensor probes. It measures the energy consumed in heating or cooling systems and displays the BTU total on the Liquid Crystal Display.

Pulse to Card Converter allows any pulse meter (gas, electric, etc.) to be compatible with and part of the Chip Card System.

Technical Specifications

Product Number	5101	5102	5201
Max. Temp. (°F)	104	190	190
Min. Flow (gpm)	0.2	0.2	0.2
Cont. Flow (gpm)	11.0	11.0	11.0
Max. Flow (gpm)	22.0	22.0	22.0
Max. Pres. (psi)	230	230	230
LCD	6-Digit	6-Digit	6-Digit
Display	Gals.	Gals.	BTU
Temp. Sensors	N/A	N/A	Platinum
Sensor Wells	N/A	N/A	3/8" NPT
Sensor Length	N/A	N/A	6'

Dimensions

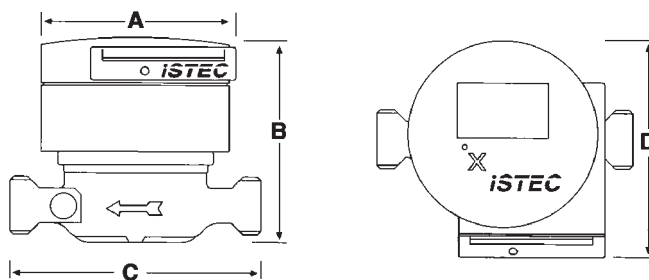

Pipe Size	A	B	C	D	Weight
3/4"	3-3/8"	3-5/8"	5-1/8"	3-15/16"	1-3/4 lbs

SUPER JET WATER METERS

1700 Series



Product Overview

ISTEC's "Super-Jet" 1700 Series Water Meters are the latest design in multi-wing flow meters. The result: high reliability with great accuracy at a low cost. The design of the "Super-Jet" flow chamber guides the water through the meter to minimize turbulence. For the 1" through 2" meters, no straight piping to the flow meter is necessary for accuracy that exceeds AWWA standards.

All ISTECH flow meters are designed with a trickle-flow indicator showing even the smallest water flow. The flow counter is non-resettable and available with contact pulsers for remote reading or computer inter-connections.

For easy installation, all ISTECH flow meters up to 1-1/2" are available with union connections and the 2" model is equipped with standard flanges. The smooth running, self-aligning turbine adds to the list of innovative features providing long life, accuracy and reliability.

Applications

- Cold Water
- Hot water
- Boiler Feed
- Heating Systems
- Cooling Systems

Technical Specifications

Meter Body	Brass (up to 1-1/2") Cast Iron (2")
Built-In Strainer	Polypropylene
O-Ring	Synthetic Rubber or Viton
Turbine	Polyamide Fiber Reinforced
Magnet	Samarium-Cobalt
Magnet Shield Ring	Steel
Pivot	Stainless Steel
Bearing	Ceramic
Register Cap	Polycarbonate
Connections	NPT or Sweat (1/2" to 1") NPT only (1-1/4" & 1-1/2") Flange (2")
Minimum Reading	0.05 Gals.
Maximum Reading	10 million US Gals. (1/2", 3/4") 100 million Gals. (1" - 2")
Accuracy	± 1-1/2%
Calibration	U.S. Gals. (Cubic Ft. available)

See page 15 for additional specifications

All Counters are non-resettable
For larger flow rates and higher temperatures, refer to 1800 Series Water Meter Specifications

Dimensions

Size	1/2	3/4	1	1-1/4	1-1/2	2
L (Body)	4-5/16	5-1/8	10-1/4	10-1/4	11-3/4	10-1/2
C (NPT)*	2-3/8	2-1/2	2-5/8	2-7/8	2-7/8	N/A
C (Sweat)	11/16	7/8	1-1/16	N/A	N/A	N/A
B (Width)	2-3/4	2-3/4	3-5/8	3-5/8	4-3/4	N/A
H (Height)	2	2	3-5/8	3-5/8	3-5/8	5-3/8
h (Height)	3/4	7/8	1-7/8	1-7/8	1-7/8	3-1/2

NOTE: All dimensions are in inches

*Short couplings available for 1/2" to 1"

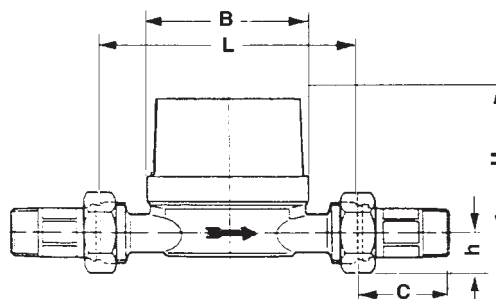

SUPER JET WATER METERS

1800 Series



Product Overview

ISTEC's "Super-Jet" 1800 Series are industrial grade water meters available in 1/2" through 12" sizes. All sizes incorporate a variety of standard features such as U.S. gallon register, hermetically sealed non-resettable counter, trickle flow indicator and pulse output. ISTEC's "Super-Jet" design leaves only the turbine immersed, resulting in reliable and long lasting performance.

For easy installation, all ISTEC flow meters up to 1-1/2" are available with union connections; 2" and larger sizes are designed with standard flanges. The smooth running turbine, together with a self-aligning suspension bearing system and other innovative features provides superior reliability and accuracy that meets or exceeds AWWA standards.

In addition, a high temperature version (350°F) of the 2", 3" and 4" meters is available.

Applications

- Cold water
- Hot Water
- Condensate
- Boiler Feed
- Heating Systems
- Cooling Systems

Technical Specifications

Meter Body	Brass (pipe size 1/2" to 1-1/2") Cast Iron (pipe size 2" and up)
Turbine	Fiberglass
Turbine axle	Chrome/Nickel/Steel
Bearing material	Stainless Steel/Sapphire
Tightening screws	Stainless steel
Magnetic transfer	Samarium-Cobalt
Gears, axles, screws	Stainless Steel
Counter Gears	Plastic
Counter axles	Chrome/Nickel/Steel
Display & housing	Plastic
Accuracy	± 1-1/2%
Calibration	U.S. Gals. (Metric Available)

See page 15 for additional specifications

All 1800 Series meters come equipped with a pulse output for remote reading or interconnection to strip recorders, computers, etc.

Dimensions

Size	1/2 (H)	3/4 (A)	1 (H)	1 (D)	1-1/2 (H)	1-1/2 (D)	2 (H)
A	3/4	3/4	1-3/4	5-7/8	2	7-7/8	3-1/4
B	3-3/4	3-3/4	5-1/2	7-1/2	6-1/4	8-3/4	7-1/8
C	4-1/2	5	10-1/4	1-1/4	11-7/8	7/8	10-1/2
Size	2 (A)	3 (A)	4 (A)	6 (A)	8 (A)	10 (A)	12 (A)
A	3	3-3/4	4-3/8	5-3/4	6-3/4	8	9
B	5-1/2	5-1/2	7-7/8	8-1/2	8-1/2	9-1/4	10-1/4
C	7-7/8	8-7/8	9-7/8	11-7/8	13-3/4	17-3/4	19-3/4

NOTE: All dimensions are in inches, (A) = Any Flow Direction
(H) = Horizontal Flow, (D) = Down Flow

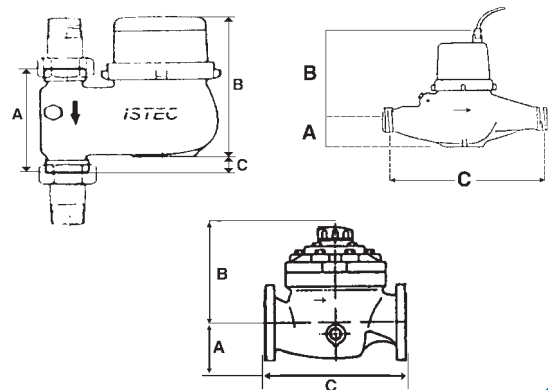

IRRIGATION METERS

1900 Series



Applications

- Irrigation
- Water Treatment
- Wells
- Agriculture
- Mining

Product Overview

ISTEC's 1900 Series Water Meters are ideally suited to measure the flow of irrigation, well water and even extremely polluted water. The practical design allows metering of liquids with up to 30% suspended solids. The entire meter is protected with an epoxy-based paint and features a self-cleaning turbine to assure perfect operation in tough environments. The vacuum-sealed counter has large, easy to read numbers and is non-resettable.

The meters range in size from 2" to 10" and can be mounted horizontally, inclined or vertical (up or down flow). Remote reading capability can easily be retrofitted onto the flow meter. The ISTEC 1900 Series: high reliability and great accuracy, at a low cost!

Features

- High Accuracy
- Large Digits for Easy Reading
- Removable Measuring Chamber
- Self-Cleaning Turbine
- Vacuum Sealed Counter
- Magnetic Coupling

Options

- Pulse Output - Reed Switch .2 Amp 24 V Rating
- Remote Reading, Data Logging, etc.

See page 15 for additional specifications

Dimensions

PIPE SIZE	H	h	L	WEIGHT (LBS)
2	6-1/8	2-15/16	7-7/8	24
2-1/2	6-1/8	3-3/8	7-7/8	29
3	6-1/8	3-3/4	8-7/8	34
4	6-1/8	4-1/8	9-7/8	42
5	6-5/8	4-3/4	9-7/8	53
6	6-5/8	5-5/16	11-7/8	66
8	7-1/8	7-1/8	13-3/4	106
10	6-1/8	7-7/8	17-3/4	187

Note: All dimensions are in inches

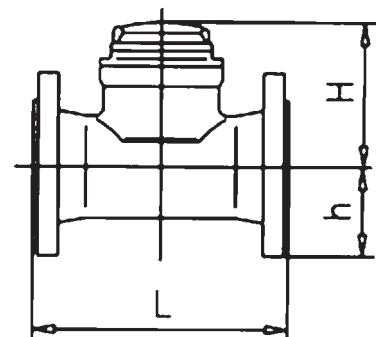

OIL METERS

9200 Series

Applications

- 2, 4 or 6 Oil
- Kerosene
- Diesel
- Gasoline
- Jet fuel
- Freon



Product Overview

ISTEC's 9200 Series are positive displacement type meters that offer very high accuracy ($\pm 1\%$) over a wide flow range. Viscosity and density do not influence their accuracy.

Two types of displays are available, mechanical (with or w/o pulse output) and electronic. The electronic counter features a LCD display with two totals (one that is resettable) as well as flow rate indication. All counters are sealed and restart at zero after reaching maximum capacity.

The 9200 Series is available with different body materials, pistons and gaskets to measure many other liquids (gasoline, freon, kerosene, etc.). They can also be ordered in matched pairs as well as in a high accuracy ($\pm 0.5\%$) version

Technical Specifications

Model	Pipe Size	Max Press PSI	Max Temp °F	Flow Range			Gals Per Pulse	Wt Lbs
				Min	Cont Gal/H	Max		
9204	1/4"	350	140	0.25	13.2	21	0.1	1.4
9208	3/8"	350	140	1	35	52.8	0.1	1.7
9215	1/2"	225	260	2.6	105	160	0.1	4.9
9220	3/4"	225	260	8	265	400	0.1	5.5
9225	1"	225	260	20	528	800	1	9.3
9240	1-1/2"	150	260	60	1600	2400	10	38
9250	2"	150	260	200	5300	8000	10	90.4

Note: 1/4" & 3/8", Pressure or Flair Fittings; 1/2" to 1-1/2", NPT Fittings; 2", Flange

Dimensions

Model #	9215	9220	9225	9240	9250
A	1/2	3/4	1	1-1/2	2
B	6-1/2	6-1/2	7-1/2	11-13/16	13-3/4
C	10-1/4	10-1/4	12	17-3/8	--
D	1-3/4	2	3	4-1/2	6-1/2
E (Mech)	2-3/8	2-3/8	2-1/2	3	3-1/4
E (LCD)	5-1/2	5-1/2	5-5/8	6-1/4	6-3/8
F	4-1/8	4-1/8	5-1/8	8-1/4	11

NOTE: All Dimensions in Inches

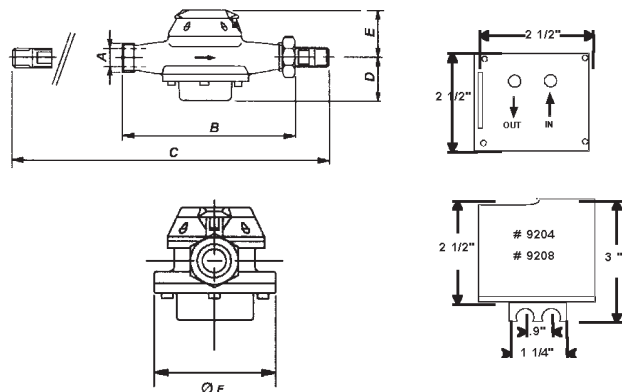

VORTEX METERS

2150 & 7150 Series



Product Overview

ISTEC's 2150 & 7150 Series Vortex Meters can be used to measure the flow of a wide variety of liquids and gases. They are available in wafer or flange configurations with various output signal and remote display options.

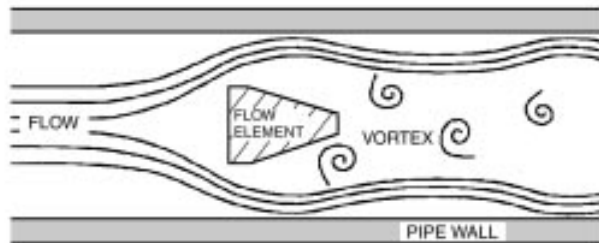

FLOW PATTERN GENERATED BY A VORTEX SHEDDING FLOW ELEMENT

When a liquid or gas flows around a fixed body (vortex shedder), flow-related effects produce vortices downstream. These vortices are shed alternatively from side to side in a regular pattern. The pressure variation caused by the vortices can be measured electronically and be converted into exact flow or volume units.

Technical Specifications

Sizes	3/4" to 8" (wafer or flange)
Pressure	Up to 1500 psig
Temperature	Up to 800°F
Accuracy	± 1.0%
Repeatability	± 0.1%
Construction	316 SS
Electronics	NEMA 4X
Power Supply	10.5 to 50VDC

Applications

- Steam
- Liquids
- Gases
- Cryogenic Fluids
- Oil

Features

- Accuracy within ± 1.0% of reading
- Remote reading capability
- Low maintenance
- Minimal pressure loss
- No recalibration
- Low total cost
- Easy installation
- Liquid, gas or steam can be measured
- All stainless steel construction
- High pressure - high temperature rating
- Rugged construction
- Repeatability ± 0.1% of reading
- Digital and/or analog output
- Fast response time

How to Order

In order to quote the correct meter, the following information is necessary:

- Type of Medium (Gas, Steam, etc.)
- Temperature (°F)
- Pressure (psi)
- Minimum Flow Rate (lbs/hr, gpm, etc.)
- Maximum Flow Rate (lbs/hr, gpm, etc.)
- Pipe Size (inches)
- Pipe Schedule (40 or 80)
- Type of Display (Rate or Rate & Total)
- Output (4-20mA Scale)

ELECTROMAGNETIC METERS

6000 Series



Product Overview

ISTEC's 6000 Series Magnetic Flowmeters are designed to measure liquids or slurries (even abrasive or corrosive fluids) with electrical conductivity. Their accuracy is unaffected by viscosity, density, pressure or other physical characteristics. Available in a number of common body (sensor) styles, these meters can be installed horizontally or vertically, even next to elbows.

Numerous Converter options are available to power the sensor coils and process the flow data. They can be mounted remotely or directly to the sensor and provide a LCD display. Standard features include multiple outputs and alarms.

Features

- Remote reading capability
- Low maintenance
- Minimal pressure loss
- Easy installation
- High pressure - high temperature rating
- Rugged construction
- Digital and/or analog output

Applications

- Liquids with Suspended Solids
- Slurries
- Corrosive Liquids
- Waste Water
- Food Products
- Beverages

Technical Specifications

Accuracy	± 0.25% from 3 ft/sec to 36 ft/sec
Sizes	1/8" to 42"
Flow	0.1 to 155,000 gpm
Styles	NPT, Tri-Clover, Wafer & Flanged
Flow Tube	Stainless Steel
Lining	PTFE, PP, EPDM & Hard Rubber
Electrodes	316 SS, Hastelloy B & C, Platinum, Tantalum or Titanium
Connections	NPT: 316 SS or Hastelloy Flange: Epoxy Coated Carbon Steel or 304 SS
Pressure	NPT: 225 psig @ Ambient Temperature Wafer: Compatible with ANSI 150 Flanged: Compatible with ANSI 150
Temperature:	NPT: Up to 300°F Wafer: Up to 356°F Flanged: Up to 356°F (1" to 8") Up to 200°F (10" to 42")

How to Order

In order to quote the correct meter, the following information is necessary:

- Type of Fluid
- Temperature (°F)
- Pressure (psi)
- Minimum Flow Rate (gpm)
- Maximum Flow Rate (gpm)
- Pipe Size (inches)

REMOTE DISPLAYS

9500 Series



Applications

- Water Meters
- Condensate Meters
- Oil Meters
- Steam Meters

Product Overview

All remote displays require a pulse or an electronic signal from the flow meter and can be interconnected to water, condensate, oil, BTU and other types of flowmeters.

The displays can be mechanical counters, liquid crystal displays (LCD) or light emitting diodes (LED).

Displays # 2 & 3 are in tough steel NEMA 1 enclosures, size: 7" x 5-3/4" x 5" (h x w x d).

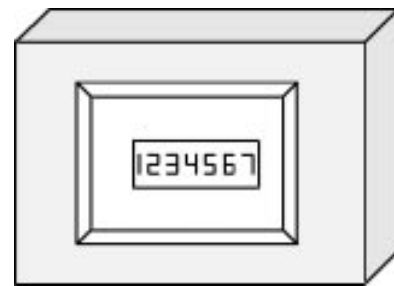

Figure #1

Technical Specifications

Model #	Display Type	Power Supply	# Digits Size	Input Signal	Special Features
9501	LED	110 VAC	6 5/8"	Pulse or Electronic	Total (Gallons)
9502	LED	110 VAC	5 5/8"	Pulse or Electronic	Rate (GPM)
9503	LED	110 VAC	5 Rate 6 Total 5/8"	Pulse or Electronic	Rate & Total
9504	LED	110 VAC	5 Rate 6 Total 5/8"	Pulse or Electronic	Rate, Total & 4-20mA
9505	LCD	Battery	5 Rate 8 Total 7/16"	Pulse	Rate & Total
9510	LCD	Battery	7 1/4"	Pulse	Total no Reset
9512	LCD	Battery	7 1/4"	Pulse	Total w/Reset
9515	LCD	110 VAC	6 Rate 8 Total 7/16"	Pulse or Electronic	Rate & Total
9530	MECH	110 VAC	7 1/4"	Pulse	Total no Reset

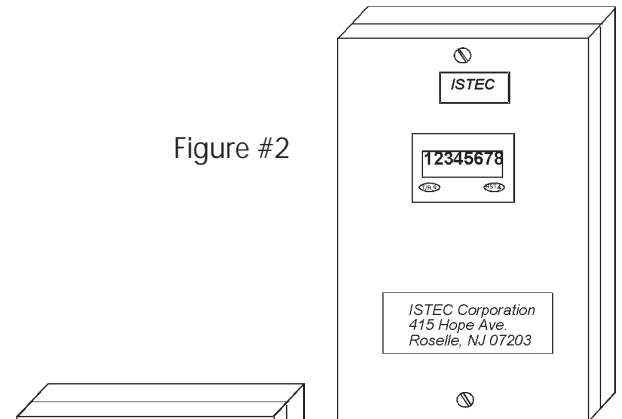

Figure #2

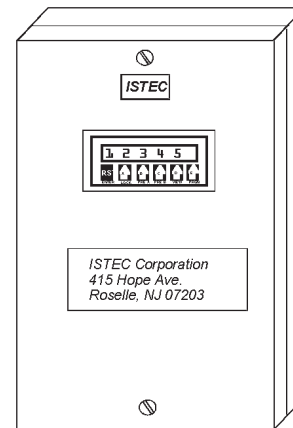

Figure #3

BALANCING VALVES

FlowGuard 2900 Series



Applications

- Heating Systems
- Cooling Systems
- Radiant Systems
- Solar Panels
- Heat Pumps
- Fan Coil Units
- Air Handling Units

Product Overview

ISTEC's FlowGuard is the perfect combination of a balancing valve and a flow rate indicator. It can be used to balance and verify the flow rate in heating, cooling, solar, radiant or heat pump systems, etc.

The FlowGuard is a very simple and accurate device. The multi-turn balancing valve adjusts the flow to the desired rate while the indicator constantly shows the momentary value. This allows for fast and easy verification, without the need for additional equipment.

With FlowGuard, easy balancing and verification of complex systems is possible.

Advantages

- Accurate flow balancing
- Visual indication of flow rate
- Self-contained balancing/reading system
- Positive shut-off
- Easy Installation
- Works In any position
- Sturdy and attractive design

Materials

- Brass body
- High temp. plastic flow indicator
- Stainless Steel spring
- EPDM Rubber O-Ring seals

Technical Specifications & Dimensions

Model #	2907	2908	2911	2912
Size (inches)	3/4	3/4	1	1-1/4
Flow Range (gpm)	0.5 - 4	1 - 9	1 - 13	2 - 21
Cv	3.5	4.1	6.4	10.5
Temp Range (°F)	38 to 212			
Max. Pressure (psi)	150			
A	3/4"	3/4"	1"	1 1/4"
B	3-3/8"	3-3/8"	4-3/4"	5-5/16"
C	2-11/16"	2-11/16"	2-7/8"	3"
D	1-5/8"	1-5/8"	2-3/4"	3"
E	2 1/2"	2 1/2"	2 5/8"	2-7/8"

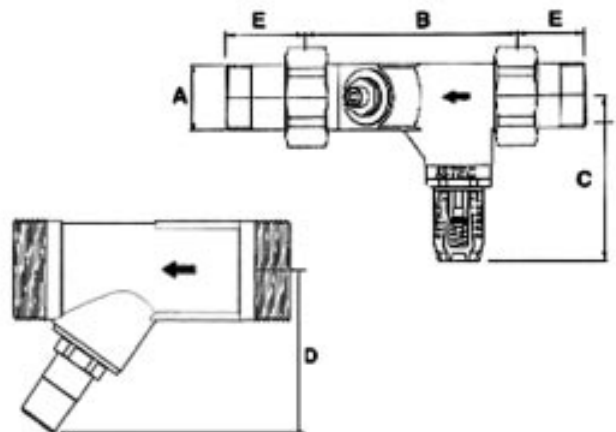

RADIATOR VALVES

2000 Series



Product Overview

The ISTEC 2000 Series Radiator Valve is a self-contained, non-electric temperature-regulating device. The rugged and reliable construction provides years of trouble-free service in hot water or steam heating systems.

The wax-type temperature sensor expands or contracts based on room temperature changes. This movement adjusts the valve opening which increases or decreases the flow through the radiator. Continual modulation of the valve reduces energy consumption and provides even temperature levels in each heating zone.

The valve's innovative design pattern minimizes expansion noise and flow sound levels. All valve sizes and patterns utilize the same insert and accommodate any ISTEC temperature controller.

Technical Specifications

Body	Nickel Plated Brass
Stem & Spring	Stainless Steel
Seat	EPDM
Max. Temperature	250°F
Maximum Pressure	
Hot Water	150 psi
Steam	15 psi
Temperature Range	40°F to 80°F

Applications

- Hot Water Heating Systems
- 1 & 2-Pipe Steam Heating Systems
- Radiant Heating Systems

Features

- Increases heating system efficiency
- Provides even room temperature
- Maximizes comfort ($\pm 1^\circ\text{F}$)
- Desired temperature can be locked or limited
- Freeze Protection
- Positive shutoff
- Prevents overheating
- Balances the heating system
- Simple, "one - trade" installation
- Fully automatic
- "Memory-Disc" setpoint reminder
- Replaceable insert (without draining system)
- No service requirements
- Vandalproof design
- Exceeds ASHRAE standards

Sizes & Styles

Valves

Sizes: 1/8", 1/2", 3/4", 1", and 1-1/4"
Styles: Straight, Angle & Horizontal Angle
Connection: NPT or Sweat (1/2" to 1")
NPT (1/8" & 1-1/4")
Insert: Standard or Reversed flow

Controls

- Manual
- Self-Contained
- Remote Sensor (6', 10' & 15')
- Remote Sensor & Controller (6')
- Armored Tubing (6' Remote sensor only)
- 24VAC (N.C. Standard, N.O. Optional)

Accessories

- Locking ring
- Actuator Extension
- Re-calibration Tool

RADIATOR VALVES

2000 Series

Dimensions

VALVE BODY

Size	1/2"	3/4"	1"	1-1/4"
A	1-7/16	1-5/8	1-3/4	2-3/8
As	2-3/16	2-7/8	3-1/4	N/A
B	2-5/16	2-1/2	3-1/8	3-1/2
Bs	1-7/8	2-1/8	2-7/8	N/A
C	1-1/8	1-1/8	1-1/8	1-5/16
D	2-3/8	2-5/8	3	3-3/8
Ds	1-7/8	2-1/4	2-5/8	N/A
E	1	1-1/8	1-3/8	1-9/16
Es	1-3/4	2-3/8	2-7/8	N/A
F	1	1	1-1/16	1-1/16
G	1-5/8	1-1/2	1-1/2	N/A
H	2-5/16	2-5/8	3	N/A
Hs	1-7/8	2-1/4	2-5/8	N/A
I	1-1/8	1-1/8	2-15/16	N/A
Is	1-3/4	3	3-5/8	N/A

CONTROLS

K	1-1/2
L	1-1/2
M	1-5/8
N	3
P	11/16
Q	3-3/16
R	2-5/8
S	3-1/8
T	1-5/8
U	2-3/8

NOTE:
ALL CONTROLS
WILL FIT
ALL VALVE
SIZES AND STYLES

ALL
DIMENSIONS
IN INCHES

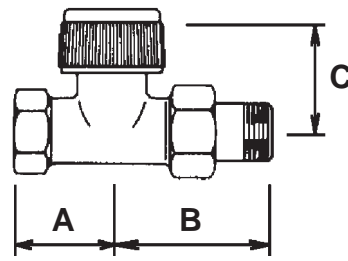

Straight

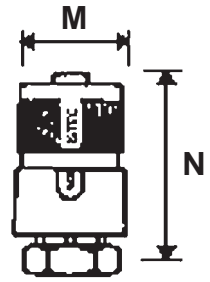

Self-Contained

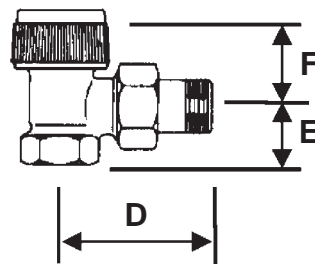

Angle

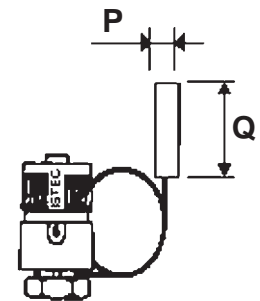

Remote Sensor

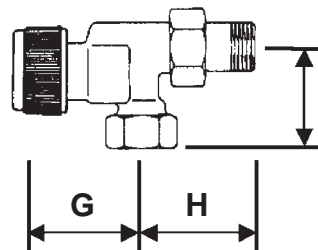

Horizontal Angle

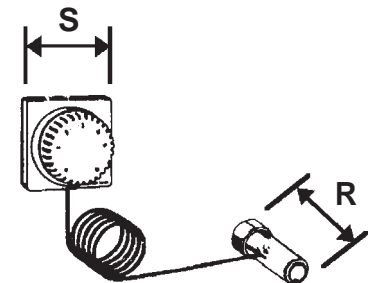

Remote Sensor/Controller

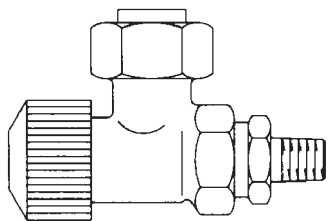

One Pipe Steam

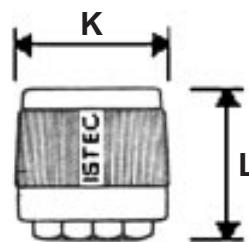

Manual

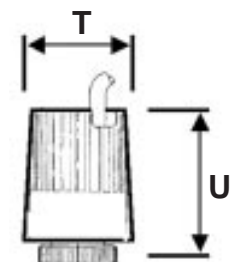

24 Volt

WATER METER SPECIFICATIONS

1700, 1800 & 1900 Series

	Product Number	Pipe Size	Maximum Rating		Flow Range GPM			Gallons Per Pulse	Flow Dir.	Weight (lbs.)
			Temp.	Press.	Min.	Cont.	Max.			
1700 Series	1700	1/2"	200°F	150 PSI	0.13	6.6	13.0	-	A	1.1
	1702	1/2"	200°F	150 PSI	0.13	6.6	13.0	1	A	1.1
	1710	3/4"	200°F	150 PSI	0.22	11.0	20.0	-	A	1.4
	1712	3/4"	200°F	150 PSI	0.22	11.0	20.0	1	A	1.4
	1720	1"	200°F	150 PSI	0.5	26.4	50.0	-	H	5.5
	1722	1"	200°F	150 PSI	0.5	26.4	50.0	1	H	5.5
	1730	1 1/4"	200°F	150 PSI	0.5	26.4	50.0	-	H	5.5
	1732	1 1/4"	200°F	150 PSI	0.5	26.4	50.0	1	H	5.5
	1740	1 1/2"	200°F	150 PSI	0.8	44.0	90.0	-	H	12.0
	1742	1 1/2"	200°F	150 PSI	0.8	44.0	90.0	1	H	12.0
	1750	2"	200°F	150 PSI	1.3	66.0	132.0	-	H	27.0
	1752	2"	200°F	150 PSI	1.3	66.0	132.0	10	H	27.0
1800 Series	1800	1/2"	248°F	232 PSI	0.13	6.6	13.2	1	A	2.3
	1805	3/4"	248°F	232 PSI	0.22	11.0	22.0	1	A	2.5
	1810	1"	248°F	232 PSI	0.4	26.3	52.6	1	H	6.4
	1811	1"	248°F	232 PSI	0.4	26.3	52.6	1	D	6.8
	1812	1"	248°F	232 PSI	0.4	26.0	52.6	1	U	6.8
	1815	1 1/2"	248°F	232 PSI	0.7	43.9	87.2	1	H	11.3
	1816	1 1/2"	248°F	232 PSI	0.7	43.9	87.2	1	D	12.1
	1820	2"	248°F	232 PSI	0.88	65.8	131.6	10	H	27.5
	1825	2"	248°F	232 PSI	2.6	66.0	264.2	10	A	24.4
	1830	3"	248°F	232 PSI	14.1	141	396.3	10	A	27.5
	1835	4"	248°F	232 PSI	5.3	263.2	790.0	10	A	43.7
	1840	6"	248°F	232 PSI	26.3	657.9	1535.0	100	A	71.6
1845	8"	248°F	232 PSI	43.9	1096.5	2631.0	100	A	99.2	
1850	10"	248°F	232 PSI	53.0	1761.0	4400.0	100	A	260.0	
1855	12"	248°F	232 PSI	66.0	2642.0	5284.0	100	A	300.0	
High Temp.	1920R	2"	350°F	195 PSI	2.6	66.0	110.0	10 or 100	H	30.9
	1930R	3"	350°F	195 PSI	7.0	176.0	308.0	10 or 100	H	44.0
	1940R	4"	350°F	195 PSI	10.5	254.0	440.0	10 or 100	H	72.8
1900 Series	1947	2"	125°F	230 PSI	10.5	132.0	308.0	-	A	24.0
	1948	2"	125°F	230 PSI	10.5	132.0	308.0	10	A	24.0
	1950	2-1/2"	125°F	230 PSI	21.0	220.0	525.0	-	A	29.0
	1952	2-1/2"	125°F	230 PSI	21.0	220.0	525.0	10	A	29.0
	1955	3"	125°F	230 PSI	21.0	400.0	660.0	-	A	34.0
	1957	3"	125°F	230 PSI	21.0	400.0	660.0	10	A	34.0
	1960	4"	125°F	230 PSI	52.0	550.0	1300.0	-	A	42.0
	1962	4"	125°F	230 PSI	52.0	550.0	1300.0	10	A	42.0
	1965	5"	125°F	230 PSI	52.0	770.0	1540.0	-	A	53.0
	1967	5"	125°F	230 PSI	52.0	770.0	1540.0	100	A	53.0
	1970	6"	125°F	230 PSI	88.0	1100.0	2200.0	-	A	66.0
	1972	6"	125°F	230 PSI	88.0	1100.0	2200.0	100	A	66.0
1975	8"	125°F	230 PSI	140.0	2000.0	4000.0	-	A	106.0	
1977	8"	125°F	230 PSI	140.0	2000.0	4000.0	100	A	106.0	
1980	10"	125°F	230 PSI	140.0	3500.0	5280.0	-	A	187.0	
1982	10"	125°F	230 PSI	140.0	3500.0	5280.0	1000	A	187.0	

- Specifications Are Subject To Change Without Notice.
- Flow Meters 1/2" - 1 1/2" Have Union Connections (Locking Nuts And Gaskets)
- Flow Meters 2" & Up Have Flanged Connections With Gaskets — ANSI Std. B16.5 (150#)
- H = Horizontal Flow Only A = Any Flow Direction (Horizontal or Vertical) D = Downflow U = Upflow

Quality & Commitment – for over twenty years

Our business was built around these simple yet crucial principles: Quality in the products and services we offer as well as an unwavering commitment to the highest level of customer response and support.

Our professional staff is trained to provide application assistance and our customer service department is ready to expedite your order. With a large inventory of product and parts, most orders can be shipped the day they are received!



ISTEC
CORPORATION

ISTEC
Flow Measurement & Control

Represented By:
Power Equipment Company
Ph. 804-236-3800, Fx. 804-236-3882, www.peconet.com