

Innovative Combustion Solutions Worldwide

GAS VENT VALVES

MODEL 8214

*Two Way Normally Open
Aluminum Bodies
3/4" to 2-1/2" N.P.T.*

Version 1.0



Eclipse Model 8214 vent valves are suited for double block and vent gas burner systems, where the valves are mounted between the shutoff valves in either main or pilot gas lines to the burner, and vented to the outside atmosphere.

These normally open valves have aluminum bodies which are mountable in any position, except for Model ECI-JB821493, which must be vertical and upright. A 1/8" N.P.T. downstream pipe tap with plug provides easy access for routine testing.

These valves are available in two models: L and JB. L models have molded epoxy Types 1, 2, 3S and 4X combination general purpose and watertight solenoid enclosures with 72" leads and 1/2" conduit hub as standard. JB models have metal Type 1 general purpose junction box enclosures with 18" leads.

- For use with fuel gas.
- Continuous duty Class F insulation coils are available in volts AC/Hz for:
 - ~ 24/60
 - ~ 120/60, 110/50
 - ~ 240/60, 220/50
 - ~ 480/60
- UL listed; AGA, CGA and CSA certified.
- Valve components in contact with fluids:
 - ~ Body: Die-cast aluminum
 - ~ Seals and disc: Buna "N"
 - ~ Core and plugnut: 430F s.s.
 - ~ Core tube: 305 s.s.
 - ~ Springs: 302 s.s.
 - ~ Shading coil: Copper
 - ~ Plug: Zinc-plated steel
 - ~ Disc holder: Nylon (*17.1 watt-rated models only*)
 - ~ Core guide: Acetal (*20 watt-rated models only*)
 - ~ Rider ring: Filled Teflon™ (*20 watt-rated models only*)



Eclipse Combustion



Specifications

Size, "N.P.T.	Eclipse Model No.	Eclipse Part No.	Cv	Gas Capacity (Btu/hr.) ^①	Operating Pressure Diff. (psi)		Fluid & Ambient Temp. (°F)		Watt Rating	Power Consumption	
					Min.	Max.	Min.	Max.		VA Holding	VA Inrush
3/4	ECI-L8214G33	20161	5.1	247,500	0	5	-40	125	17.1	40	93
1	ECI-JB821453	20162	21.0	1,179,000	0	5	-40	125	20.0	43	240
1-1/4	ECI-JB821463	20163	32.0	1,538,000	0	5	-40	125	20.0	43	240
1-1/2	ECI-JB821473	20164	35.0	1,615,250	0	5	-40	125	20.0	43	240
2	ECI-JB821483	20165	60.0	2,924,500	0	5	-40	125	20.0	43	240
2-1/2	ECI-JB821493 ^②	20166	109.0	6,220,750	0	5	-40	125	28.2	50	385

① For 1" w.c. pressure drop at 2" w.c. inlet pressure, 1,000 Btu/cu. ft. or more, for gas @ 0.64 specific gravity.

② Must be mounted with solenoid vertical and upright.

Vent Pipe Sizes (as recommended by I.R.I.)

Pipe Type	Pipe Size Diameters, In Inches					
Fuel*	≤1-1/2	2	2-1/2	3	4	6
Vent	3/4	1	1-1/4	1-1/4	2	2-1/2

* If the fuel pipe diameter is smaller than 3/4", then the vent pipe diameter must be equal to the cross sectional area of the fuel pipe.

Dimensions

Model Number	Size, "N.P.T.	Valve Style	Dimensions, In Inches						
			A	B	C	D	E	F	G
ECI-L8214G33	3/4	1	2-15/16	4-1/16	4-7/8	3-5/16	2-3/8	—	3-11/16
ECI-JB821453	1	2	2-1/4	3-5/8	6-13/16	5	5-3/8	2-5/8	6-3/16
ECI-JB821463	1-1/4	2	2-3/16	3-9/16	6-13/16	5	5-3/8	2-5/8	6-3/16
ECI-JB821473	1-1/2	2	2-3/16	3-9/16	6-13/16	5	5-3/8	2-5/8	6-3/16
ECI-JB821483	2	2	2-7/16	3-13/16	7-7/16	6-1/8	6-5/16	2-13/16	6-3/8

Valve Style 1

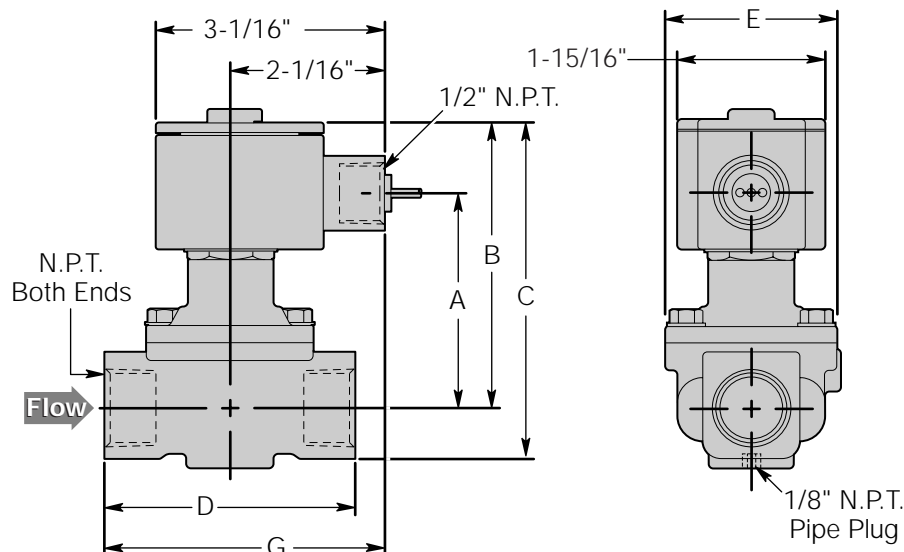

Dimensions (continued)

Valve Style 2

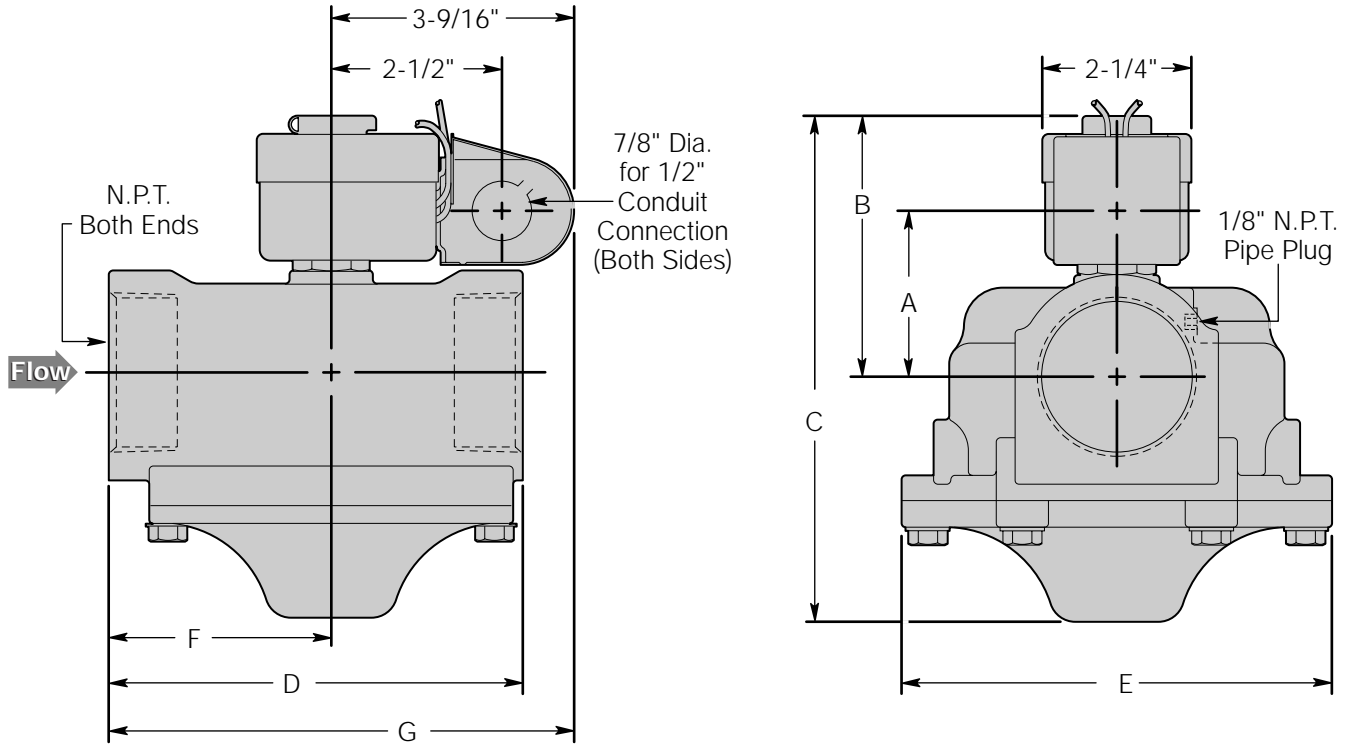

Model #ECI-JB821493 Valve

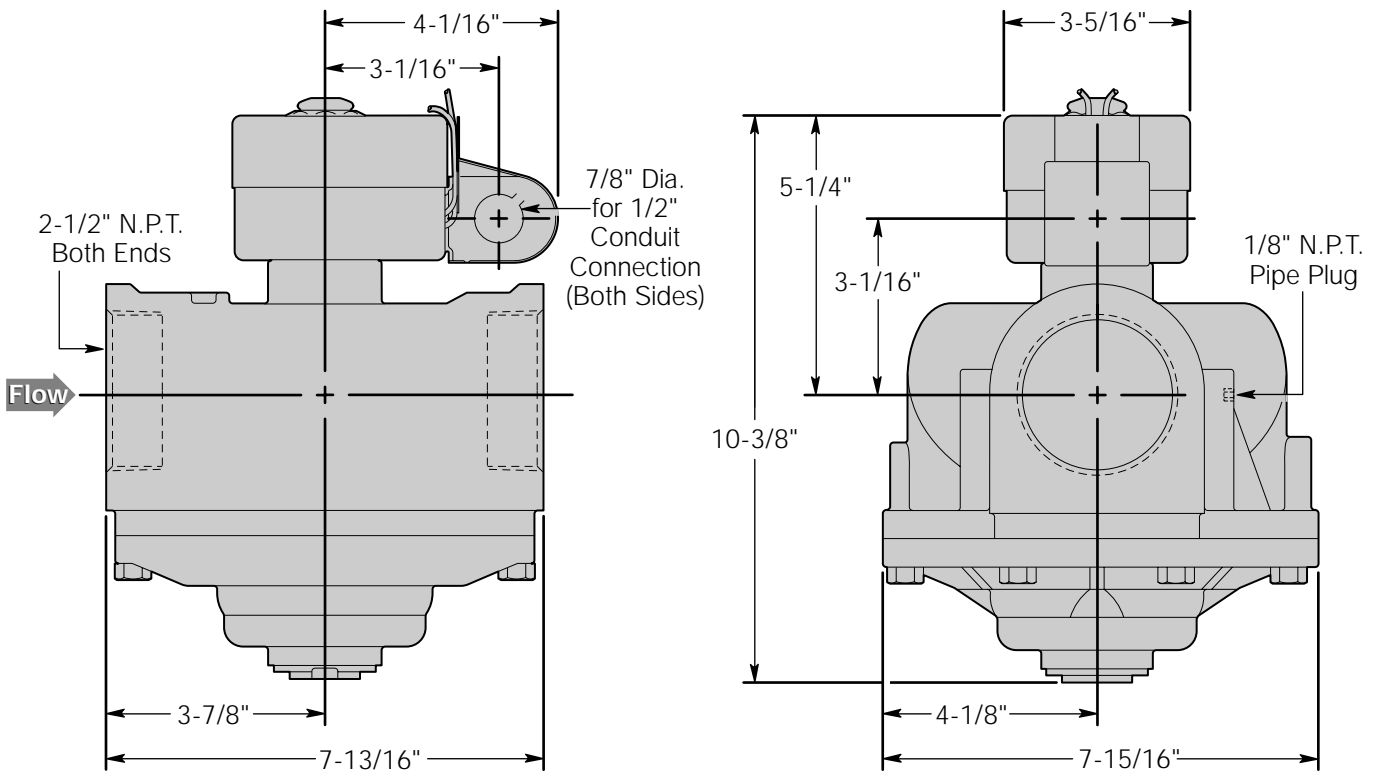

NOTE: This valve model must be mounted with the solenoid vertical and upright.



Eclipse Combustion

Offered By:

Power Equipment Company
2011 Williamsburg Road
Richmond, VA 23231
Phone: 804-236-3800 Fax: 804-236-3882

www.peconet.com