

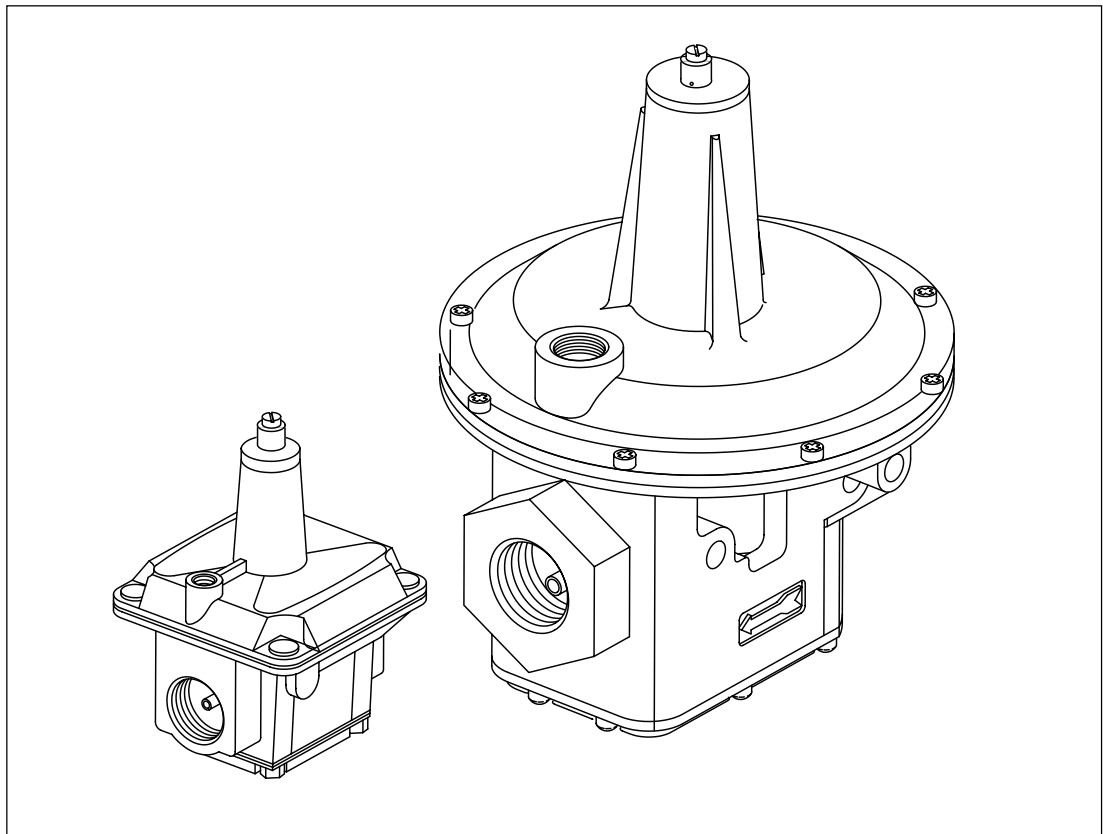

Eclipse Ratio Regulators

ES Series



Eclipse Combustion

ISO 9001 Registered

COPYRIGHT

Copyright 1997 by Eclipse Combustion, Inc. All rights reserved worldwide. This publication is protected by federal regulation and shall not be copied, distributed, transmitted, transcribed or translated into any human or computer language, in any form or by any means, to any third parties, without the express written consent of Eclipse Combustion, Inc., Rockford, Illinois, U.S.A.

DISCLAIMER NOTICE

We reserve the right to change the construction and/or configuration of our products at any time without being obliged to adjust earlier supplies accordingly.

The material in this manual is believed adequate for the intended use of the product. If the product, or its individual modules or procedures, are used for purposes other than those specified herein, confirmation of their validity and suitability must be obtained. Eclipse Combustion, Inc. warrants that the material itself does not infringe any United States patents. No further warranty is expressed or implied.

We have made every effort to make this manual as accurate and complete as possible. Should you find errors or omissions, please bring them to our attention so that we may correct them. In this way we hope to improve our product documentation for the benefit of our customers. Please send your corrections and comments to our Documentation Manager.

LIABILITY AND WARRANTY

It must be understood that Eclipse Combustion's liability for its products, whether due to breach of warranty, negligence, strict liability, or otherwise, is limited to the furnishing of such replacement parts and Eclipse Combustion will not be liable for any other injury, loss, damage or expenses, whether direct or consequential, including but not limited to loss of use, income or damage to material arising in connection with the sale, installation, use of, inability to use or the repair or replacement of Eclipse Combustion's products.

Any operation expressly prohibited in this Guide, any adjustment, or assembly procedures not recommended or authorized in these instructions shall void the warranty.



About this manual

AUDIENCE

This manual has been written for people who are already familiar with all aspects of a combustion system and its add-on components, also referred to as “the burner system.”

The audience is expected to have had experience with the ratio regulator component of a burner system.

SCOPE

Contents

This manual contains essential information that you need to deal with the ratio regulator component of a burner system

Purpose

The purpose of this manual is to make sure that the ratio regulator component of a burner system is used in a safe, effective and trouble free manner.

DOCUMENT CONVENTIONS

Special Symbols

There are several special symbols in this document. You must know their meaning and importance. The explanation of these symbols follows below. Please read it thoroughly.



Danger:

Indicates hazards or unsafe practices which WILL result in severe personal injury or even death.

Only qualified and well trained personnel are allowed to carry out these instructions or procedures.

Act with great care and follow the instructions.

DOCUMENT CONVENTIONS (CONTINUED)

HOW TO GET HELP

Special Symbols (continued)



Warning:

Indicates hazards or unsafe practices which could result in severe personal injury or damage.

Act with great care and follow the instructions.



Caution:

Indicates hazards or unsafe practices which could result in damage to the machine or minor personal injury.

Act carefully.



Note:

Indicates an important part of the text. Read thoroughly.

If you need help, you can contact your local Eclipse Combustion representative. You can also contact Eclipse Combustion at any of the addresses listed on the back of this document.



Table of contents

	About this manual	3
	Table of Contents	5
1	Introduction	7
	Product Description	7
2	Safety	9
	Introduction	9
	Safety	9
	Capabilities	9
	Operator Training	9
3	Specifications	10
	Flow vs. Pressure Drop	11
	Dimensions	12
4	Design	13
5	Installation	14
	General Information	14
	Ratio Regulator/Pipe Connections	15
	Gas Bias Adjustment	15

This page left blank intentionally.

Introduction

1

PRODUCT DESCRIPTION

The ES-Series ratio regulators are used in applications where gas to air proportional flow is required. The gas flow is controlled as a function of the air pressure through a loading line which connects into the top of the regulator. As the system air pressure increases, it forces the ratio regulator valve to open causing the outlet pressure to increase until the two pressures balance. As the load line pressure increases, the ratio of the outlet pressure to the load line pressure will be slightly less than 1:1

The ratio regulators have a bias adjustment for varying the gas flow when setting the burner at low fire. It can be used to increase or decrease the gas flow resulting in gas rich or lean combustion. The adjustment is restricted in the gas rich direction therefore limiting the gas flow at zero air pressure.



Warning:

The ratio regulators are control valves only and cannot be used as gas shut-off valves.

Figure 1.1 **Ratio Regulators**

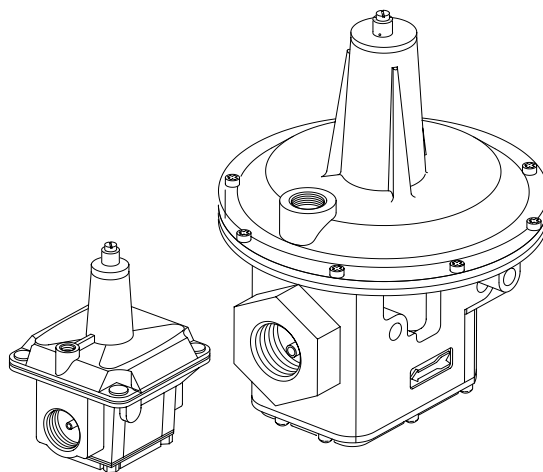

PRODUCT FEATURES

The ratio regulators are designed to optimize performance as ambient temperature and inlet pressure vary. Features include:

- UL recognized and CE approved for natural gas, propane, and butane.
- Valve seat design for consistent low fire repeatability.
- Balanced double diaphragm design allows regulator to operate over a wide range of inlet pressures while minimally affecting outlet pressure.
- Rugged die cast aluminum housing.
- Corrosion resistant internal components.
- Synthetic rubber diaphragms for excellent low temperature performance.
- Inlet pressure tap with connector (1-1/2", 2" & 3" NPT (Rp) models only).



INTRODUCTION

SAFETY

CAPABILITIES

OPERATOR TRAINING

REPLACEMENT PARTS

Important notices about safe ratio regulator operation will be found in this section.



Danger:

Do not bypass any safety feature.

Never try to use a ratio regulator that shows signs of damage or appears to be malfunctioning.



Notes:

This manual gives information for the use of these ratio regulators within their specific design purpose. Do not deviate from any instructions or application limits in this manual without written advice from Eclipse Combustion.

Read this entire manual before attempting to start the system. If any part of the information in this manual is not understood, then contact your local Eclipse Combustion representative or Eclipse Combustion before continuing.

Adjustment, maintenance and troubleshooting of the mechanical parts of this system should be done by qualified personnel with good mechanical aptitude and experience with combustion equipment.

The best safety precaution is an alert and competent operator. Thoroughly instruct operators so they demonstrate an understanding of the equipment and its operation.

Order replacement ratio regulators from Eclipse only.

Specifications

3

SPECIFICATIONS

Table 3.1 Compatibility/Temperature Specifications

Compatible Gases:	Ambient Temperature Range:
Natural, manufactured, mixed liquified petroleum or LP gas-air mixture	-40° F to 205° F -40°C to 96.1°C



Caution:

Below 32° F(0°C), the gas must be free of water vapor which could condense and freeze within the valve.

Table 3.2 Model Specifications

Model	Part Number	Pipe Thread	Maximum Inlet Pressure ①	Capacity ②
ES365	19997	3/4" NPT	1.0 psi	1,245 scfh
ES365M	19998	Rp 3/4	69.2 mbar	35.27 Nm ³ /hr
ES366	15939	1" NPT	1.0 psi	1,380 scfh
ES366M	19999	Rp 1	69.2 mbar	39.09 Nm ³ /hr
ES363	20312	1-1/2" NPT	5.0 psi	6,350 scfh
ES363M	20311	Rp 1-1/2	346.2 mbar	179.9 Nm ³ /hr
ES368	10315	2" NPT	5.0 psi	11,600 scfh
ES368M	19990	Rp 2	346.2 mbar	328.6 Nm ³ /hr
ES369	10316	3" NPT	5.0 psi	26,000 scfh
ES369M	19989	Rp 3	346.2 mbar	736.5Nm ³ /hr

① Gas inlet pressure must be greater than the total of the outlet pressure plus the pressure drop across the regulator at the required flow.

② Capacity for natural gas (0.60 s.g.) When using propane or butane, divide capacity by conversion factors listed in Table 3.3

Graph 3.1 Flow vs. Pressure Drop, 3/4" & 1" NPT (Rp) Models

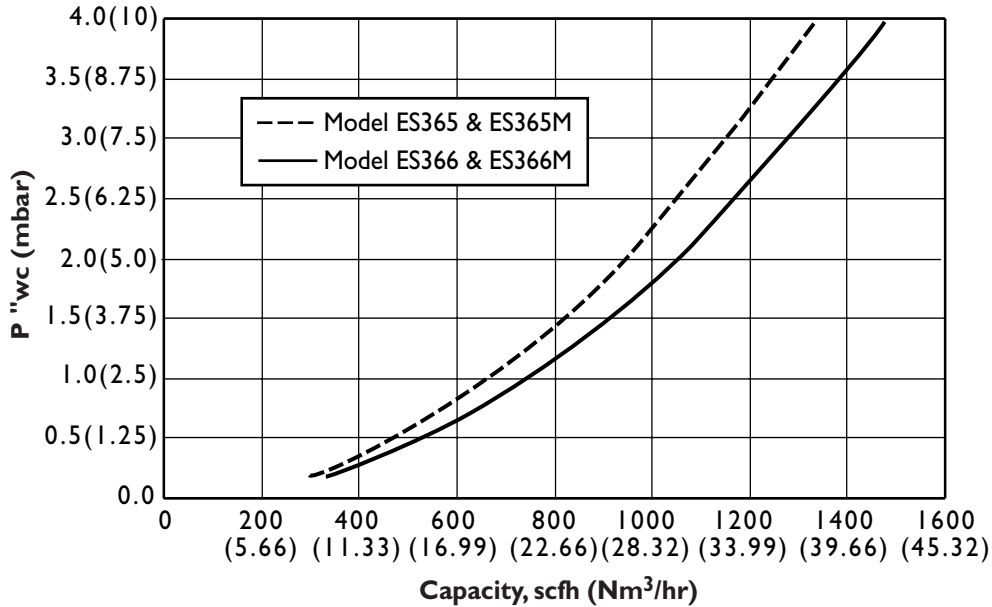

Graph 3.2 Flow vs. Pressure Drop, 1-1/2", 2" & 3" NPT(Rp) Models

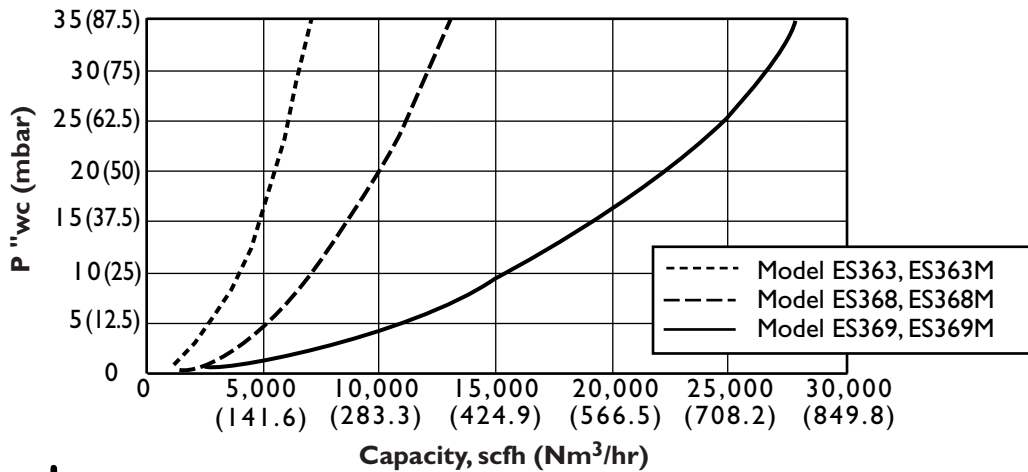

Note:

Above graphs are for natural gas (0.60 s.g.). For propane or butane, multiply the gas flow by the factors listed below, to calculate the equivalent natural gas flow, then find the pressure drop from the above graphs.

Table 3.3 Conversion Factors

GAS	CONV. FACTOR
Propane (1.5 s.g.)	1.58
Butane (2.0 s.g.)	1.82

Example: Find the pressure drop created by 15,000 scfh of propane through an ES369 ratio regulator.

1. Convert propane to the equivalent natural gas flow: $15,000 \times 1.58 = 23,700$ scfh.
2. Plot the point where 23,700 scfh crosses the ES369 curve on the above graph.
3. Translate the intersection point back to the Pressure Drop axis.
4. The pressure drop at 23,700 scfh natural gas, equivalent to 15,000 scfh propane, is approximately 23.5" wc.

Figure 3.1 Dimensions, Models ES365(M) & ES366(M)
Dimensions are in inches (mm)

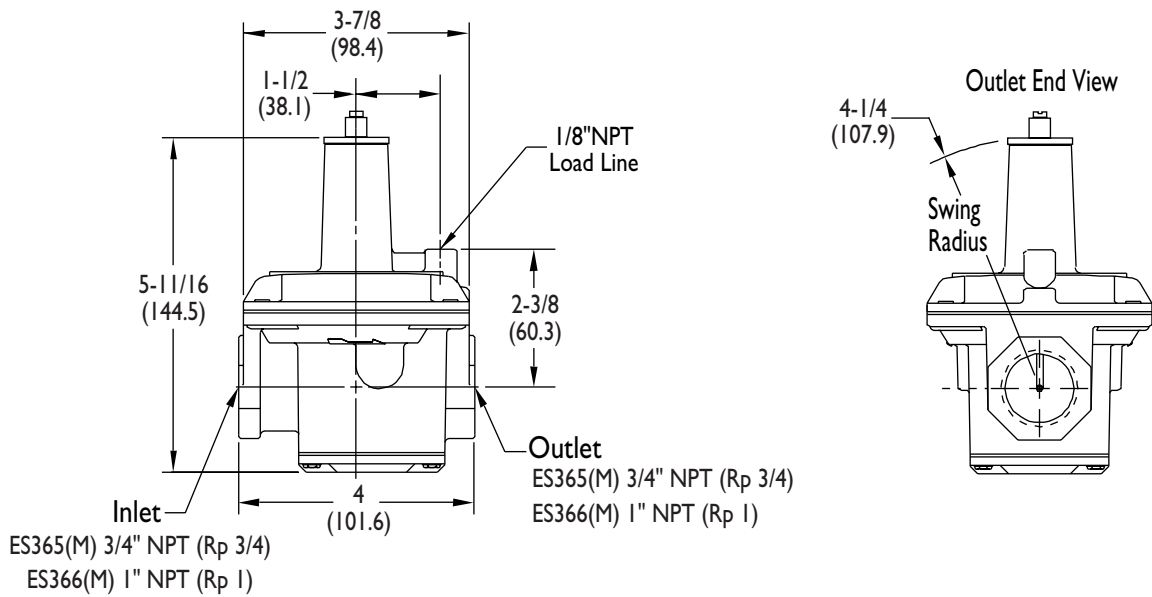
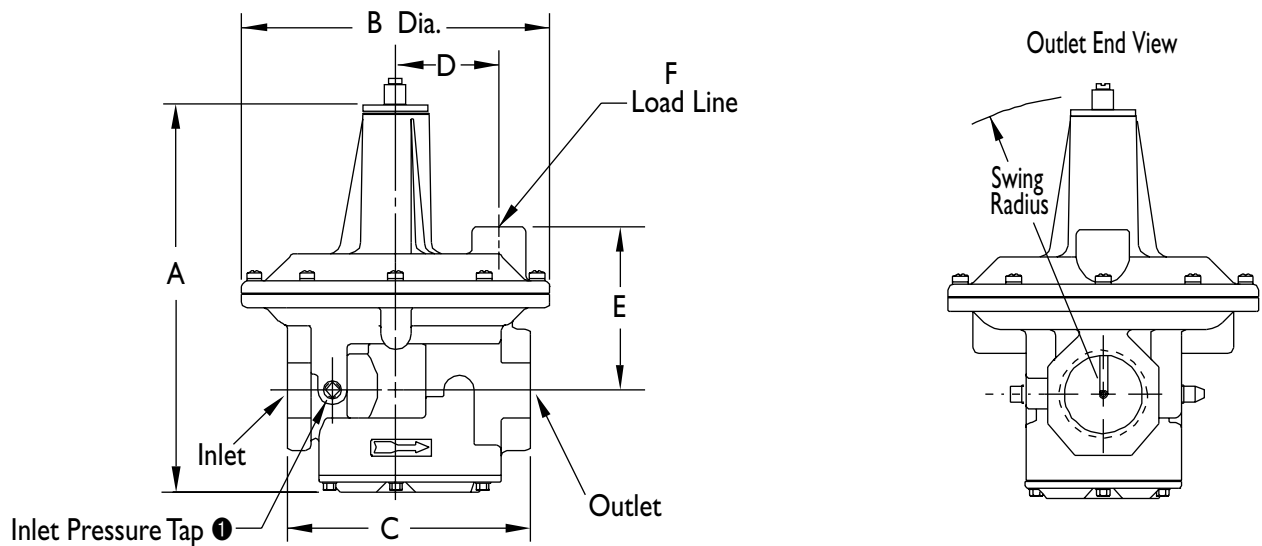

Figure 3.2 Dimensions, Models ES363(M), ES368(M) & ES369(M)



① Both sides on ES363(M) and ES368(M). Far side only on ES369(M).

Model	Swing Radius	Inlet/Outlet	A	B	C	D	E	F
ES363	5-7/16"	1-1/2" NPT	9"	7"	5-1/2"	2-3/8"	3-3/4"	1/2"NPT
ES363M	138.1mm	Rp 1-1/2	228.6mm	177.8mm	139.7mm	60.3mm	92.2mm	Rp 1/2
ES368	8-5/16"	2" NPT	11-1/4"	9-1/8"	7-5/8"	3-1/8"	4-5/16"	3/4"NPT
ES368M	211.1mm	Rp 2	285.7mm	231.7mm	193.6mm	79.3mm	109.5mm	Rp 3/4
ES369	11-13/16"	3" NPT	16-1/16"	13-7/16"	10-3/8"	4-7/8"	6-1/8"	3/4"NPT
ES369M	300mm	Rp 3	407.9mm	341.3mm	263.5mm	123.8mm	155.5mm	Rp 3/4

DESIGN

To select the ratio regulator best suited for a combustion system, several parameters need to be considered. The following steps identify those items that need to be considered when selecting a ratio regulator:

1. Ratio regulator selection based on flow:

- Define the maximum gas flow required for the system.
- Identify the ratio regulator for that flow based on the capacities listed in Table 3.2 of the Specification section.

2. Minimum inlet pressure calculation:

- Define the pressure drop through the ratio regulator based on the Flow vs. Pressure Drop curves (Graphs 3.1 & 3.2) and conversion factors listed in the Specification section.
- Calculate the pressure losses through components mounted between the ratio regulator and the burner.
- Define the gas pressure required at the burner.
- Calculate the minimum inlet pressure to ratio regulator by taking 125% of the sum between the ratio regulator drop, component drops and burner pressure.
- Verify that the inlet pressure is within the ratio regulator limit. If not, make the necessary changes to the ratio regulator or the upstream pressure control.

Installation

5

INSTALLATION

Compatible Gases:	Ambient Temperature Range:
Natural, manufactured, mixed liquified petroleum or LP gas-air mixture	-40° F to 205°F -40° C to 96.1°C



Caution:

Below 32°F (0° C), the gas must be free of water vapor which could condense and freeze within the valve.



Warning:

Shut off gas supply before installing or removing the ratio regulator.

GENERAL INSTALLATION INFORMATION

- Gas flow through the ratio regulator must be in the direction of the arrow on the body.
- Ambient temperature at the valve location must remain between -40°F and 205°F (-40°C and 96.1° C).
- The ratio regulator must be mounted with the spring tower in the vertical upright position.
- Allow clearance above the ratio regulator to allow access to the bias adjustment.
- Pipe ends are to be free of foreign material (excluding pipe dope) before connecting into the ratio regulator body.
- Do not use the ratio regulator to support adjacent piping.

REGULATOR/PIPE CONNECTIONS

GAS BIAS ADJUSTMENT

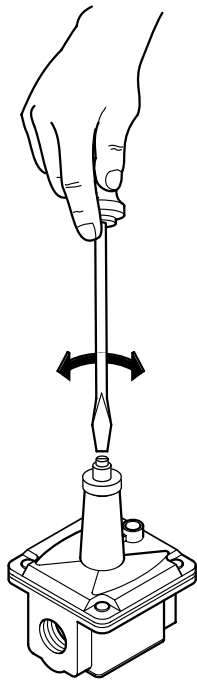

1. Remove the protective caps from the ends of the ratio regulator.
2. Apply a moderate amount of pipe dope to the male pipe threads only.



Note:

Excessive pipe dope could contaminate the valve seat thus affecting pressure regulation.



Caution:

Regulator must be installed with spring tower pointing upward, with flow in the direction of the cast arrow on regulator body.

3. Install the ratio regulator with the flow in the direction of the flow arrow on the body.
4. When tightening the pipe into the valve body, hold the end of the regulator adjacent to that pipe.
5. Connect the air pressure loading line into the vent on the top of the ratio regulator. The ratio regulators can be adjusted to bias the gas outlet pressure relative to the combustion air pressure when setting low fire flows. Adjust the regulator as follows:



Note:

Gas-rich adjustment is limited. If the spring adjustment will not produce the desired outlet pressure, make sure that the supply pressure is at least equal to the desired outlet pressure plus the pressure drop across the regulator at the required flow.

1. Set the burner air flow to low fire according to the instructions furnished with the burner.
2. Open the gas shutoff valves to allow gas flow to the burner. Ignite the burner.
3. Measure the fuel/air ratio using a flue gas analyzer, metering orifices or estimate the ratio from flame appearance. Use a screw driver to turn the adjusting screw clockwise to increase the outlet pressure or counterclockwise to decrease to outlet pressure (see figure, left).
4. Turn the combustion air to high fire and make sure the burners stay lit.



Note:

Some models are equipped with a pressure tap on the upstream side. It is open when the screw inside the tap is unscrewed approximately 1/2 a turn.



Eclipse Combustion

Offered By:

Power Equipment Company
2011 Williamsburg Road
Richmond, VA 23231
Phone: 804-236-3800 Fax: 804-236-3882

www.peconet.com