

Innovative Combustion Solutions Worldwide

Eclipse

Ratio Regulators

ES Series



The ES-Series ratio regulators are used in applications where gas to air proportional flow is required. The gas flow is controlled as a function of the air pressure through a loading line which connects into the top of the regulator. As the system air pressure increases, it forces the ratio regulator valve to open causing the outlet pressure to increase until the two pressures balance. As the load line pressure increases, the ratio of the outlet pressure to the load line pressure will be slightly less than 1:1.

The ratio regulators have a bias adjustment for varying the gas flow when setting the burner at low fire. It can be used to increase or decrease the gas flow resulting in gas rich or lean combustion. The adjustment is restricted in the gas rich direction therefore limiting the gas flow at zero air pressure.

Ratio Regulators are control valves only and cannot be used as gas shut-off valves.

PRODUCT FEATURES

The ratio regulators are designed to optimize performance as ambient temperature and inlet pressure vary. Features include:

- UL recognized and CE approved for natural gas, propane, and butane.
- Valve seat design for consistent low fire repeatability.
- Balanced double diaphragm design allows regulator to operate over a wide range of inlet pressures while minimally affecting outlet pressure.
- Rugged die cast aluminum housing.
- Corrosion resistant internal components.
- Synthetic rubber diaphragms for excellent low temperature performance.
- Inlet pressure tap with connector (1-1/2", 2" & 3" NPT (Rp) models only).
- High turndown option available.



Eclipse Combustion



Compatibility/Temperature Specifications

Compatible Gases:	Ambient Temperature Range:
Natural, manufactured, mixed liquified petroleum or LP gas-air mixture	-40° F to 205° F -40°C to 96.1°C

Caution: Below 32° F (0°C), the gas must be free of water vapor which could condense and freeze within the valve.

Model Specifications

Model	Part Number	Pipe Thread		Maximum Inlet Pressure ❶		Capacity ❷	
				psi	mbar	scfh	Nm ³ /hr
ES365	19997	3/4" NPT		1.0 psi		1,245 scfh	
ES365M	19998				69.2 mbar		35.27 Nm ³ /hr
ES366	15939	1" NPT		1.0 psi		1,380 scfh	
ES366M	19999				69.2 mbar		39.09 Nm ³ /hr
ES363	20312	1-1/2" NPT		5.0 psi		6,350 scfh	
ES363M	20311				346.2 mbar		179.9 Nm ³ /hr
ES368	10315	2" NPT		5.0 psi		11,600 scfh	
ES368M	19990				346.2 mbar		328.6 Nm ³ /hr
ES369	10316	3" NPT		5.0 psi		26,000 scfh	
ES369M	19989				346.2 mbar		736.5 Nm ³ /hr

- ❶ Gas inlet pressure must be greater than the total of the outlet pressure plus the pressure drop across the regulator at the required flow.
- ❷ Capacity for natural gas (0.60 s.g.) When using propane or butane, divide capacity by conversion factors listed below.

Flow vs. Pressure Drop, 3/4" & 1" NPT (Rp) Models

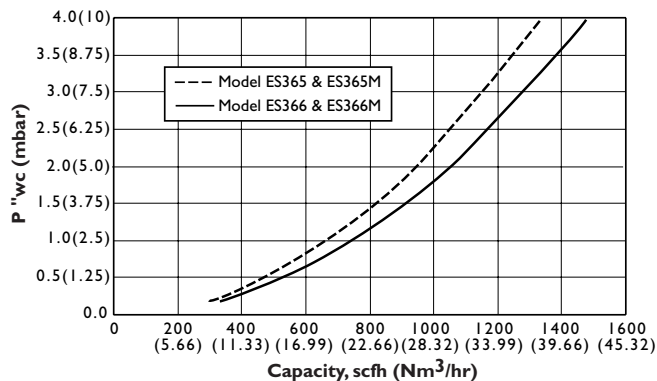

Flow vs. Pressure Drop, 1-1/2", 2" & 3" NPT(Rp) Models

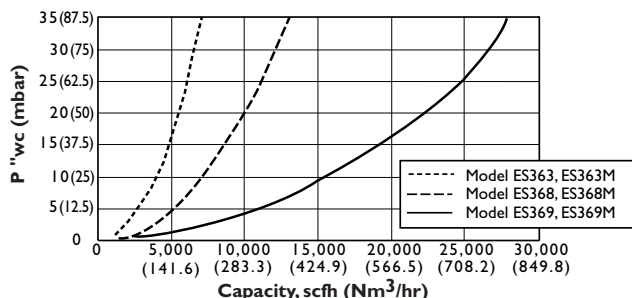

Note: These graphs are for natural gas (0.60 s.g.). For propane or butane, multiply the gas flow by the factor listed below to calculate the equivalent natural gas flow, then find the pressure drop from the above graphs.

Conversion Factors

GAS	CONV. FACTOR
Propane (1.5 s.g.)	1.58
Butane (2.0 s.g.)	1.82

Example: Find the pressure drop created by 15,000 scfh of propane through an ES369 ratio regulator.

1. Convert propane to the equivalent natural gas flow: 15,000 x 1.58 = 23,700 scfh.
2. Plot the point where 23,700 scfh crosses the ES369 curve on the above graph.
3. Translate the intersection point back to the Pressure Drop axis.
4. The pressure drop at 23,700 scfh natural gas, equivalent to 15,000 scfh propane, is approximately 23.5" wc.

Dimensions, Models ES365(M) & ES366(M)
Dimensions are in inches (mm)

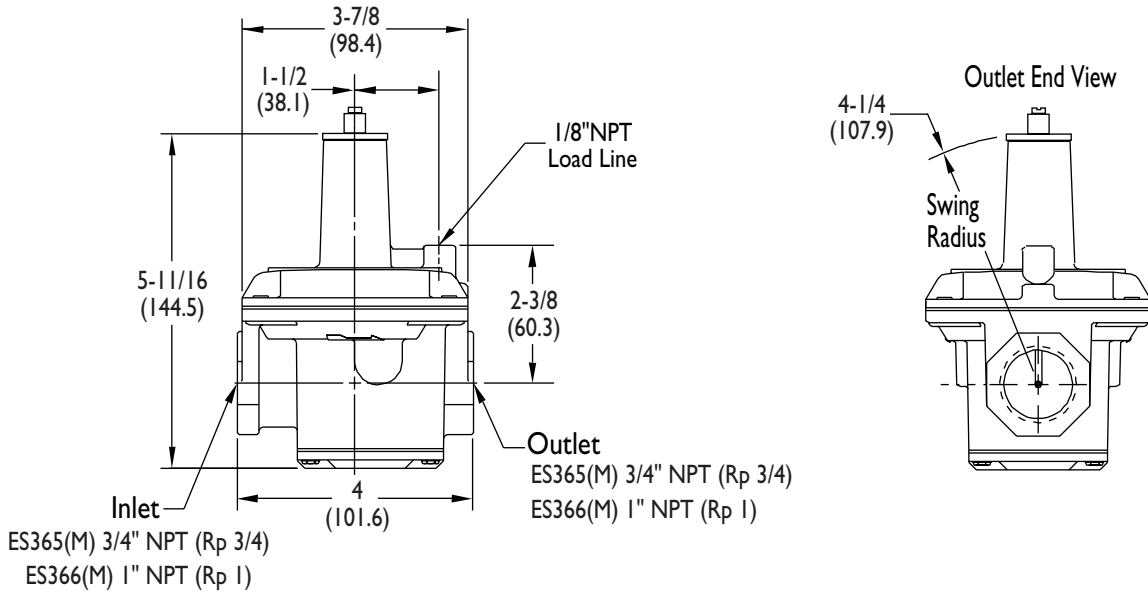

Dimensions, Models ES363(M), ES368(M) & ES369(M)

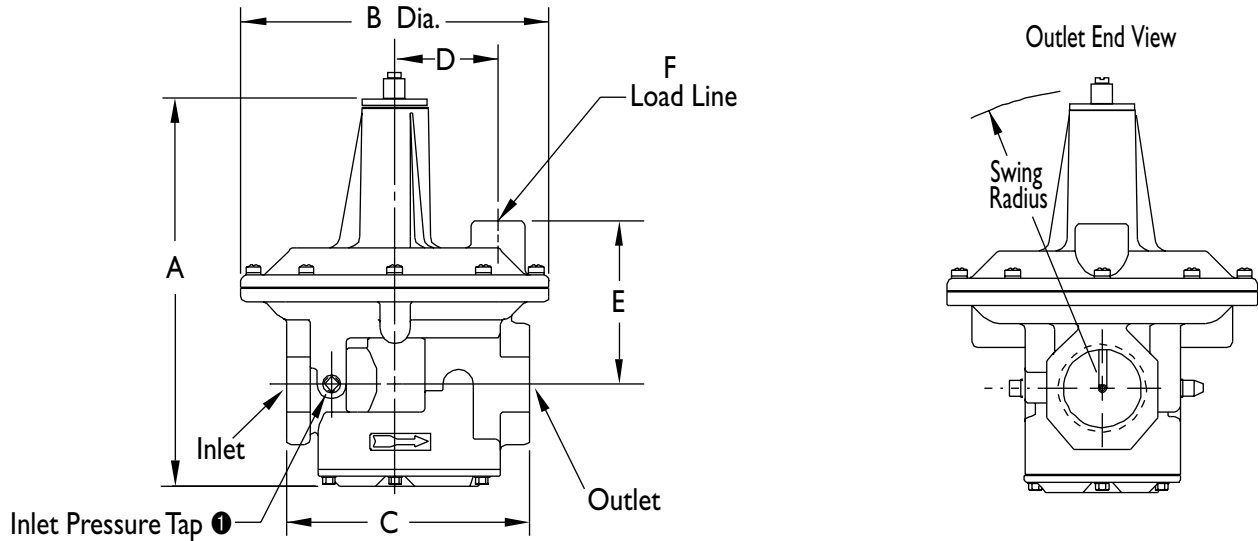

1 Both sides on ES363(M) and ES368(M). Far side only on ES369(M).

Model	Swing Radius	Inlet/Outlet	A	B	C	D	E	F
ES363	5-7/16"	1-1/2" NPT	9"	7"	5-1/2"	2-3/8"	3-3/4"	1/2"NPT
ES363M	138.1mm	Rp 1-1/2	228.6mm	177.8mm	139.7mm	60.3mm	92.2mm	Rp 1/2
ES368	8-5/16"	2" NPT	11-1/4"	9-1/8"	7-5/8"	3-1/8"	4-5/16"	3/4"NPT
ES368M	211.1mm	Rp 2	285.7mm	231.7mm	193.6mm	79.3mm	109.5mm	Rp 3/4
ES369	11-13/16"	3" NPT	16-1/16"	13-7/16"	10-3/8"	4-7/8"	6-1/8"	3/4"NPT
ES369M	300mm	Rp 3	407.9mm	341.3mm	263.5mm	123.8mm	155.5mm	Rp 3/4

Model Selection

Select a combustion system ratio regulator based on the following considerations:

1. Ratio regulator selection based on flow:

- Define the maximum gas flow required for the system.
- Identify the ratio regulator for that flow based on the capacities listed in Model Specification Chart on page 2.

2. Minimum inlet pressure calculation:

- Define the pressure drop through the ratio regulator based on the Flow vs. Pressure Drop curves and conversion factors listed in the Specification section.
- Calculate the pressure losses through components mounted between the ratio regulator and the burner.
- Define the gas pressure required at the burner.
- Calculate the minimum inlet pressure to ratio regulator by taking 125% of the sum between the ratio regulator drop, component drops and burner pressure.
- Verify that the inlet pressure is within the ratio regulator limit. If not, make the necessary changes to the ratio regulator or the upstream pressure control.

Contact your Eclipse Combustion representative, or the factory, for help in selecting the proper ratio regulator for your application



Eclipse Combustion

Offered By:

Power Equipment Company
2011 Williamsburg Road
Richmond, VA 23231
Phone: 804-236-3800 Fax: 804-236-3882

www.peconet.com