

ECLIPSE EXTERN-A-THERM RECUPERATORS

SERIES "M"

EXTERN-A-THERM
LESS HOUSING



HOUSING STYLE "ST"

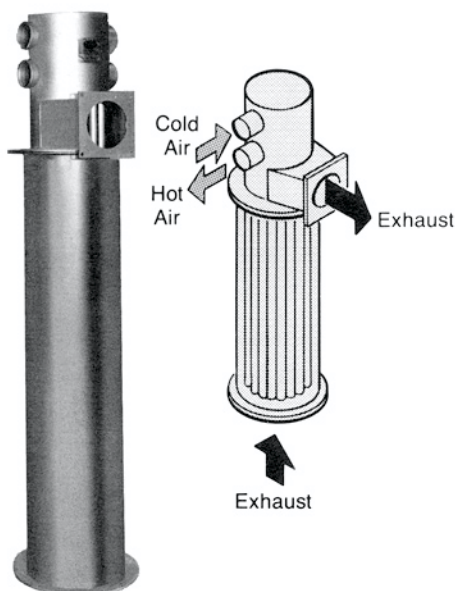

HOUSING STYLE "DL"

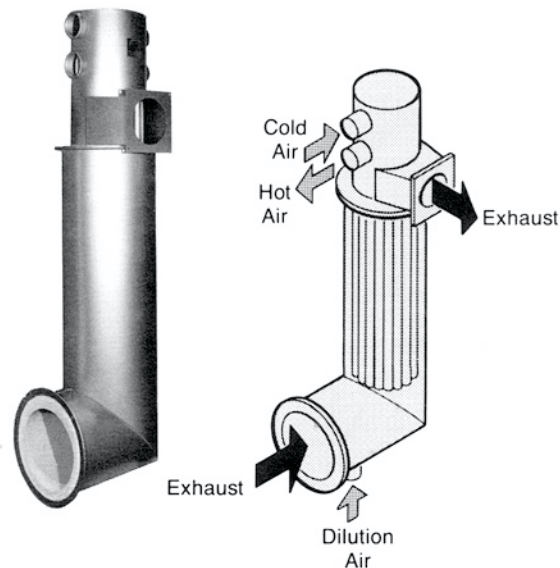

"T" STYLE RECUPERATOR & HOUSING

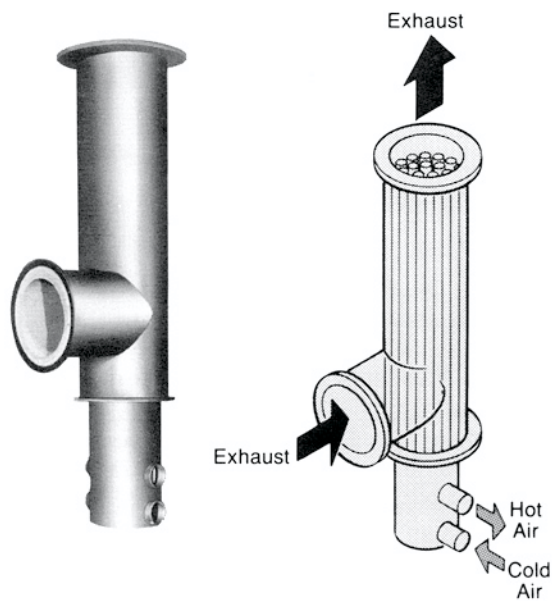

Eclipse Extern-a-Therm recuperators are tubular air-to-air heat exchangers designed to recover waste heat from industrial exhaust gases. The heat recovered is used to preheat combustion air for the system's burners, thereby increasing fuel efficiency. The accompanying table indicates the preheated air temperatures and fuel savings possible. Typical applications include aluminum crucible melting and holding, dry hearth aluminum melting, steel and alloy annealing, hardening, and forging.

Extern-a-Therm recuperators are constructed of high grade nickel-chromium stainless steel. They are mounted in carbon steel housings lined with insulation suited to the application. Three different housing configurations can be supplied to accommodate various mounting arrangements. The recuperator may also be rotated within the housing to position the air and exhaust connections as required.

Four Extern-a-Therm sizes are available for furnace inputs from 100,000 Btu/Hr. to 2,500,000 Btu/Hr. Performance data is shown on page 2.

Percent Fuel Savings At Various Furnace
Exhaust Temperatures & Combustion Air Preheats

Furnace Exhaust Temp. °F.	Preheated Air Temp. °F.				
	700	800	900	1000	1100
2400	29%	32%	35%	38%	41%
2200	26%	29%	31%	34%	36%
2000	23%	26%	28%	31%	33%
1800	21%	23%	26%	28%	31%
1600	19%	22%	24%	26%	28%
1400	18%	20%	22%	24%	26%
1200	17%	19%	21%	23%	25%
1000	15%	18%	20%	—	—

Fuel — Natural Gas @ 10% excess air.

ADVANTAGES

- • • Lightweight, durable construction
- • • Easy installation
- • • Single-ended tube design eliminates troublesome expansion joints
- • • Low pressure drops
- • • Built-in dilution air intake if required



Eclipse Combustion

ISO 9001 Registered

PERFORMANCE DATA

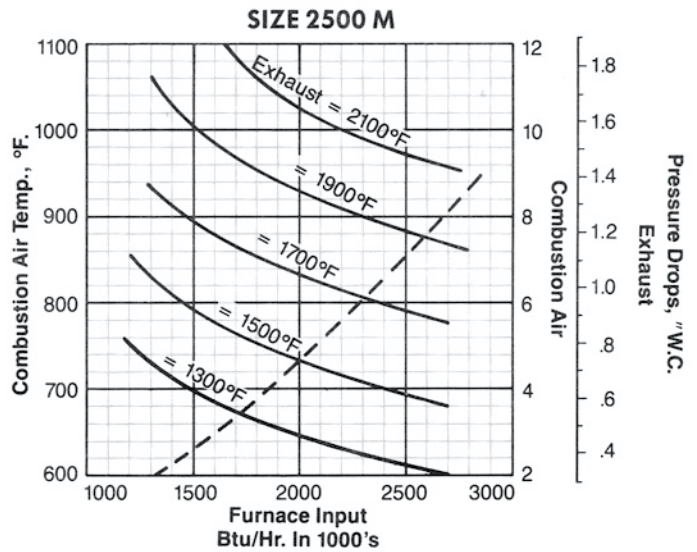
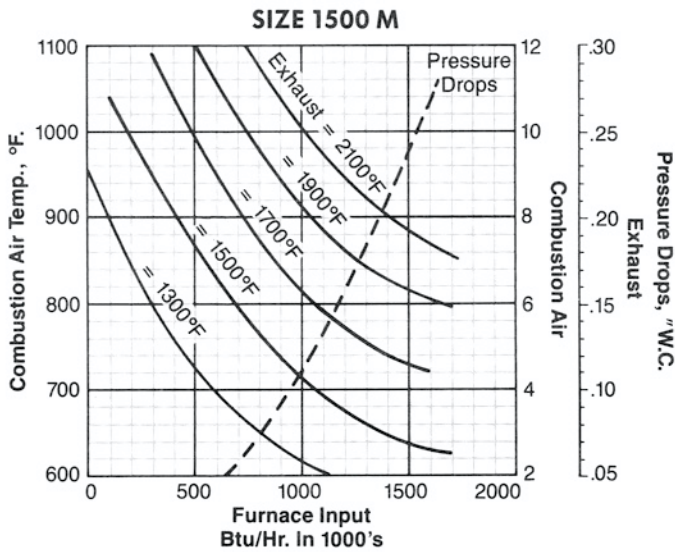
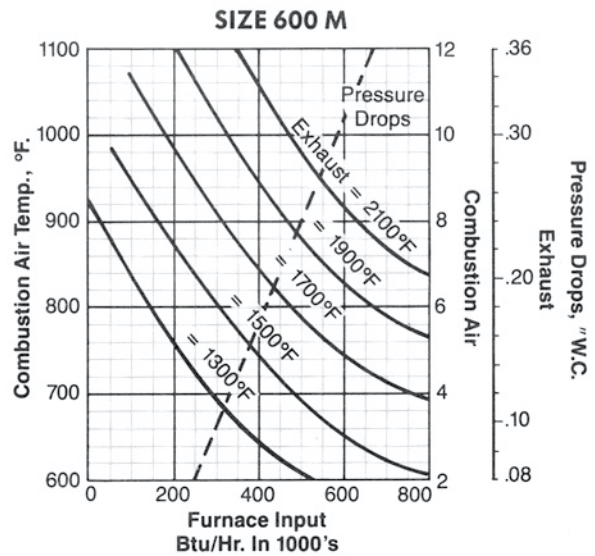
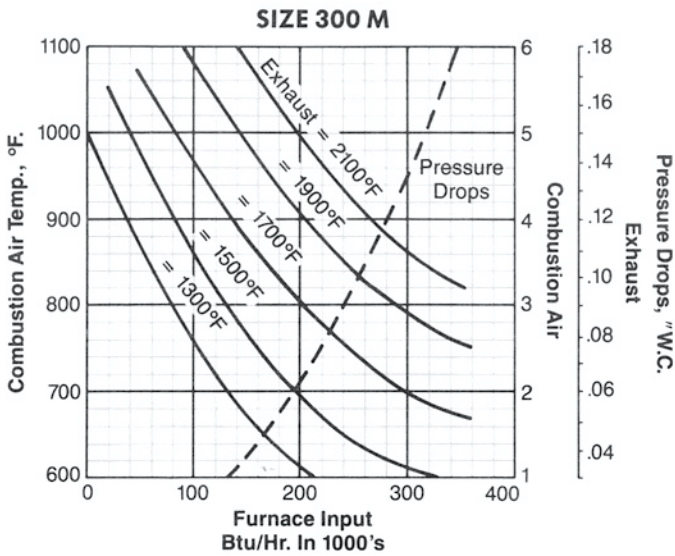

CALCULATIONS

To Find Preheated Air Temperature: Find furnace input on bottom scale. Move up to appropriate furnace exhaust temperature, then move left to combustion air temperature.

To Find Fuel Savings: Find preheated air temperature as described above. Using the Fuel Savings chart on page 1, read percent fuel savings at the intersection of the column for the preheated air temperature and the row for furnace exhaust temperature.

To Find Air & Exhaust Pressure Drops: Find furnace input on bottom scale. Move up to dashed curve for pressure drops, then move right to air & exhaust pressure drops.

Example: A furnace with an input of 750,000 Btu/Hr. has an exhaust temperature of 2300° F. What will be the preheated air temperature, fuel savings, and pressure drops produced using an External-Therm recuperator?

Because of the 2300° F. exhaust temperature, a "DI" style housing must be selected and dilution air must be used to reduce the flue temperature within the recuperator to 2100° F. When reading the Performance Data charts, then, the 2100° F. exhaust line should be used.

From the chart for the 600 M size, preheated air temperature is estimated at 850° F. Referring to the Fuel Savings chart on page 1, an 850° preheat temperature and a 2300° F. furnace exhaust temperature produce a fuel savings of approximately 29%. Returning again to the Performance chart for the 600 M, we find that the dashed pressure drop line is off the chart, indicating pressure drops much too high for practical applications. The 1500 M size must be considered.

Repeating the sizing procedure using the chart for the 1500 M, preheated air temperature is estimated at 1100° F., and fuel savings are estimated at 38%. Combustion air pressure drop will be approximately 2.5" w.c., and exhaust pressure drop will be .08", well within the range of combustion systems using combustion air blowers and exhaust fans.

DIMENSIONS—STYLE "DL"

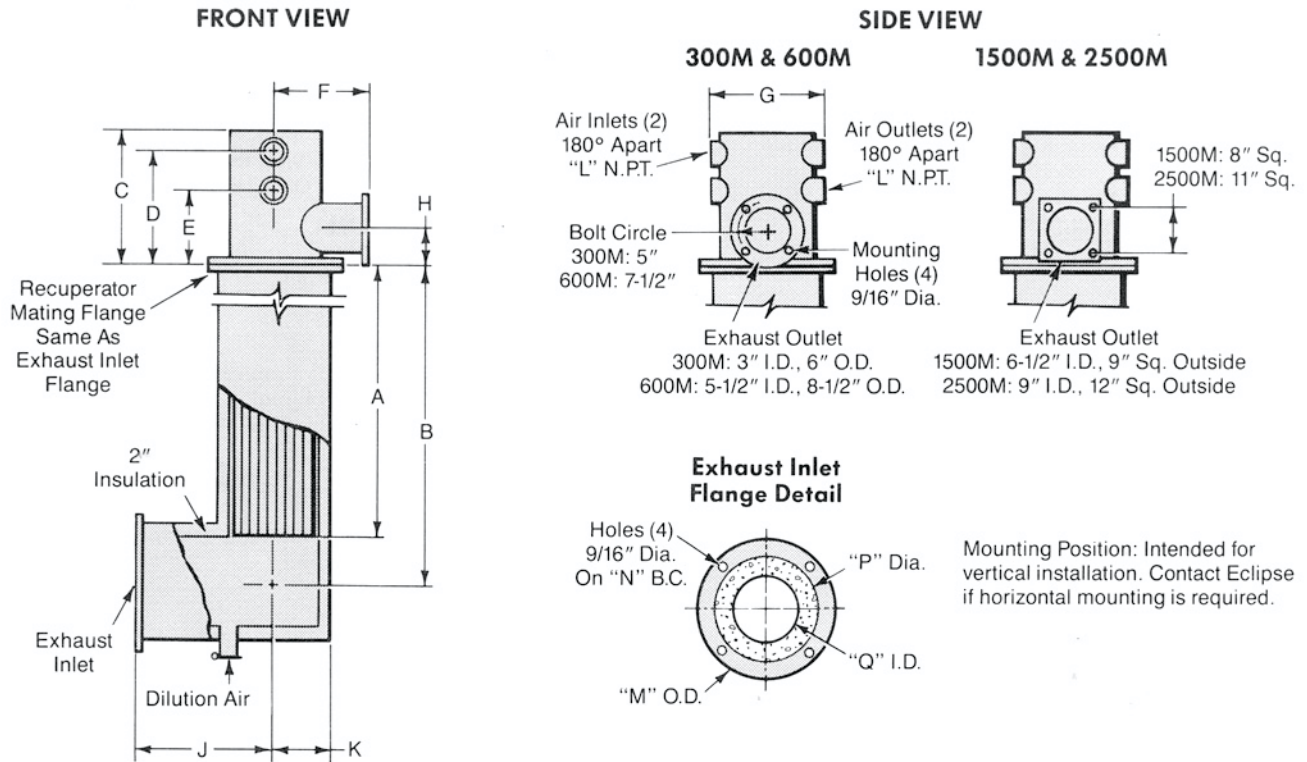

Size	Dimensions In Inches														
	A	B	C	D	E	F	G	H	J	K	L	M	N	P	Q
300 M	36	40	13-1/2	11	6-1/2	7	7-13/16	2-1/2	10	5	2	12-1/2	11-1/2	10	6
600 M	48	53	16-1/2	14	9	7-1/2	9-1/2	3-3/4	11	5-1/2	2-1/2	13-1/2	12-1/2	11	7
1500 M	48	55	19-1/2	16-1/2	11	10	14-3/16	3-1/2	13	7-3/4	3	18	17	15-1/2	11-1/2
2500 M	48	57	26-3/4	23-1/2	16	12	18	4-3/4	15	9-1/2	4	21-1/2	20-1/2	19	15

STYLE "ST"

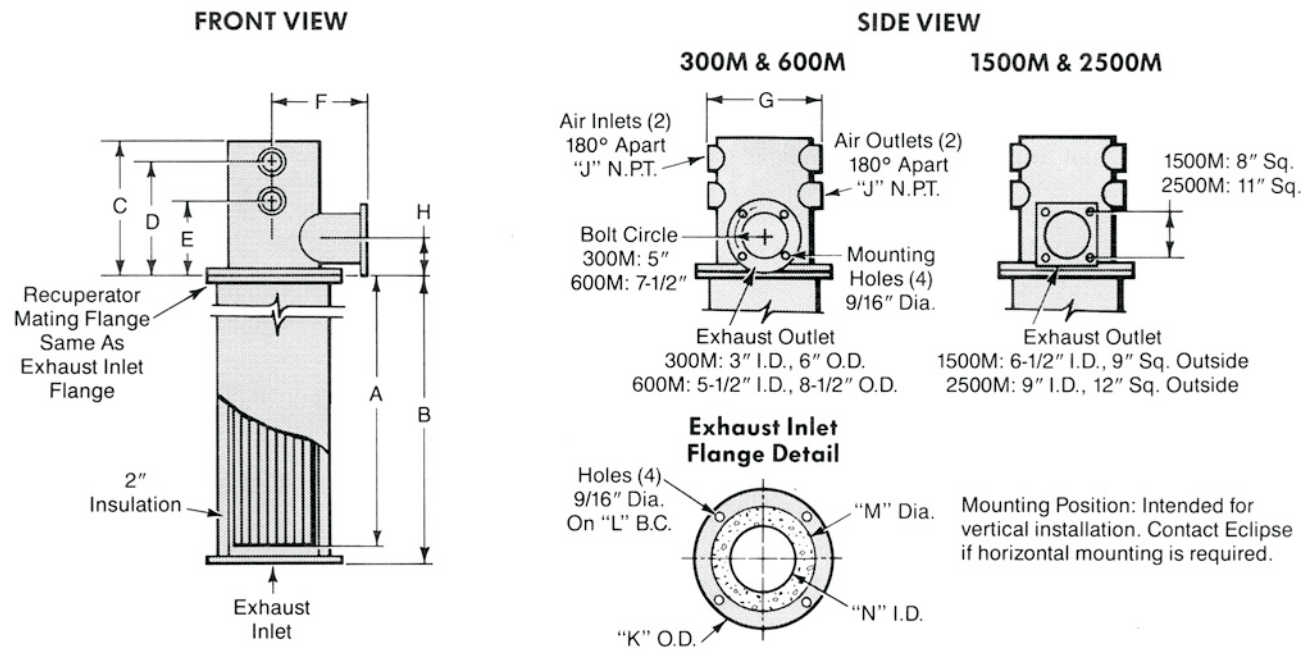

Size	Dimensions In Inches													
	A	B	C	D	E	F	G	H	J	K	L	M	N	
300 M	36	38	13-1/2	11	6-1/2	7	7-13/16	2-1/2	2	12-1/2	11-1/2	10	6	
600 M	48	50	16-1/2	14	9	7-1/2	9-1/2	3-3/4	2-1/2	13-1/2	12-1/2	11	7	
1500 M	48	50	19-1/2	16-1/2	11	10	14-3/16	3-1/2	3	18	17	15-1/2	11-1/2	
2500 M	48	50	26-3/4	23-1/2	16	12	18	4-3/4	4	21-1/2	20-1/2	19	15	

DIMENSIONS—STYLE "T"

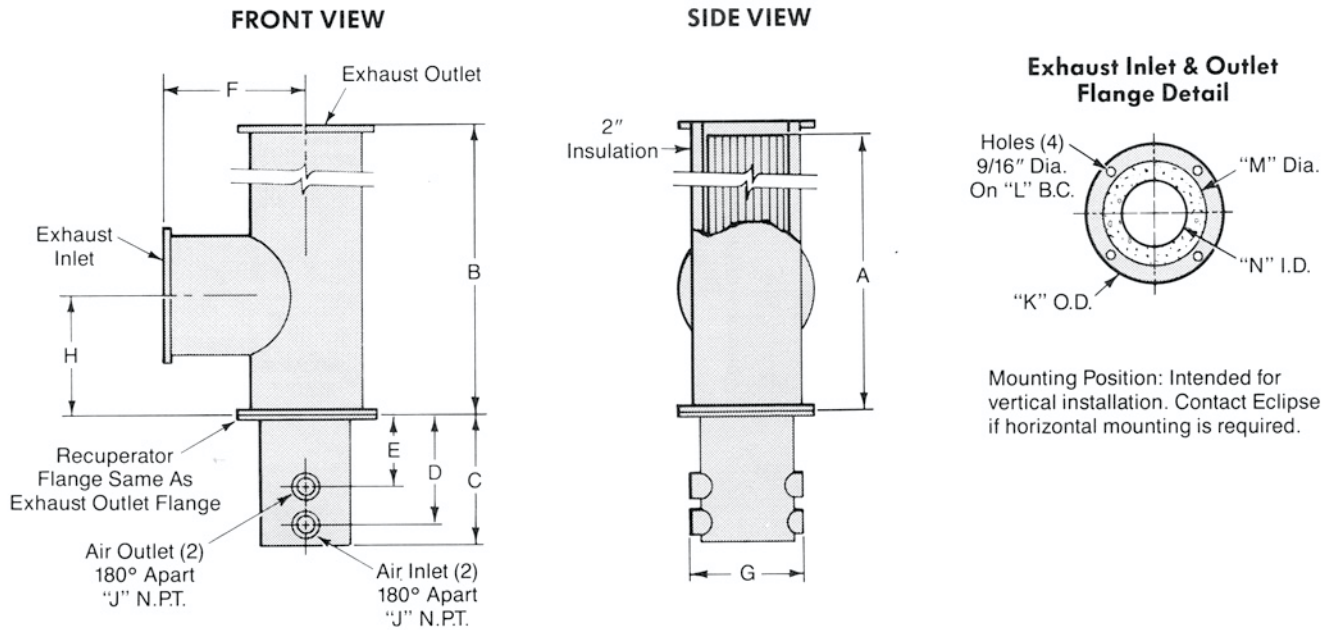

Size	Dimensions In Inches												
	A	B	C	D	E	F	G	H	J	K	L	M	N
300 M	36	38	11	8-1/2	4	12-1/2	9	6	2	12-1/2	11-1/2	10	6
600 M	48	50	12	9-1/2	4-1/2	8-1/2	9-1/2	6	2-1/2	13-1/2	12-1/2	11	7
1500 M	48	50	13-1/2	10-1/2	5	11	14	9	3	18	17	15-1/2	11-1/2
2500 M	48	50	16-1/4	13	5-1/2	12-1/2	18	10-1/2	4	21-1/2	20-1/2	19	15

IMPORTANT

Do not operate these recuperators...

- With excess fuel—either gas or oil.
- With any fluxing materials in the flue gas.
- With any chloride, sulfide, potassium, sodium, or lithium salts in the flue gas.
- With flue gas inlet temperatures exceeding:
 - Model ST: 2100°F.
 - Model T: 2100°F.
 - Model DL: 2100°F. without dilution air.
2400°F. with dilution air
- Without high temperature limit protection for each recuperator when furnace temperatures are higher than 2100°F.
- Without a positive flue gas bypass system during the fluxing cycle of aluminum melting furnaces.
- With less than low air flow when flue gas temperatures are above 1400°F.

FAILURE TO OBSERVE THESE CONDITIONS CAN DESTROY THE RECUPERATOR AND WILL VOID THE WARRANTY.



Eclipse Combustion

ISO 9001 Registered



Eclipse Combustion

Offered By:

Power Equipment Company
2011 Williamsburg Road
Richmond, VA 23231
Phone: 804-236-3800 Fax: 804-236-3882

www.peconet.com