



**EXOTHERMICS, INC.**

**World Class Heat Exchangers**

# High Temperature Insulated Heat Recuperators "IR"

## "IR" Stainless Recuperator

The IR heat recuperator achieves top heat transfer efficiency by exposing a maximum surface area to the largest possible amount of hot gas. The unit uses a proprietary counterflow design that produces improved heat transfer between two airstreams. Surface exposure is increased by corrugating heat transfer plates to achieve a sinusoidal wave pattern. The plates are spaced 1/2" apart for maximum air flow and minimum pressure drop. This design creates

air flow turbulence as the air passes counterflow through the unit, maximizing heat transfer.



As your process air enters the unit, it is directed over the corrugated plates in a counterflow direction to the heated air.

Heat from the waste stream is absorbed by the plates and transferred to the cooler airstream...then

exits the unit as recovered heat you can reuse or recycle. Airstream temperature can

be as high as 1500°F. The unit is equipped with all welded bellows type internal expansion joints of a high-temperature alloy. This allows for the expected growth when operating at high temperatures. Four inches of high-temperature insulation reduces heat loss through the exterior stainless steel casing.

## Fitting the "IR" to Your Application

We begin by analyzing your application needs to determine what is required for maximum effectiveness.

We gather and process data from you including hours of operation, fuel cost, air temperatures, and air volumes. This results in a custom application analysis that offers you several options for efficiency and ROI.

Next, your recuperator is manufactured to your precise specifications by our trained, skilled technicians using our proprietary construction procedures.

## An Exothermics Overview

Industrial clients around the world have come to rely on Exothermics for highly effective, reliable, high quality air heat recovery equipment.

Exothermics has been the leading source of industrial heat exchangers for many industrial, OEM and end-user clients since 1976. This includes clients in the automotive, textile, plastic, chemical, food, graphic arts, paper, metal finishing, rubber, pollution control, process heating and many other industries. Applications include combustion preheat, indirect air heaters, heat recovery for ovens, dryers and furnaces, thermal and catalytic incinerators and general process heating.

The high quality and structural integrity of our products has earned the trust and confidence of our customers...even in harsh environments. We seek long-term relationships with our customers.

**ISO 9001 Registered Quality System**



**World Class Heat Exchangers**

# Performance: Superior By Design

Get the added effectiveness provided by 4" of high-temperature insulation with Exothermics, Inc. Insulated Recuperator. Designed for applications up to 1500°F, the insulated recuperator is constructed from special high-temperature alloys. The all welded assembly protects from airstream cross contamination.

The insulation between the inner and outer casing of the unit greatly diminishes heat loss.

Roll-formed metallic internal expansion joints allow for the thermal expansion that accompanies high-temperature operation. Optional airflow configurations are available to fit the needs of your high-temperature thermal incinerators, furnaces and combustion preheat systems.

Individual plates are continuously welded to form a series of passages with a minimum 1/2" spacing between plates. Primary seal welds at each end of the unit separate the two airstreams, making the unit virtually leak-free. By utilizing different plate sizes, the heat transfer effectiveness range is 50% to +70%.

## Features

- 4" High-Temperature Insulation
- Fully Welded Construction
- 3" Stainless Steel Flanges
- Designed to Allow Internal Thermal Expansion

- High-Temperature Alloy Construction
- W-I-D-E Plate Spacing
- Temperatures to 1500°F

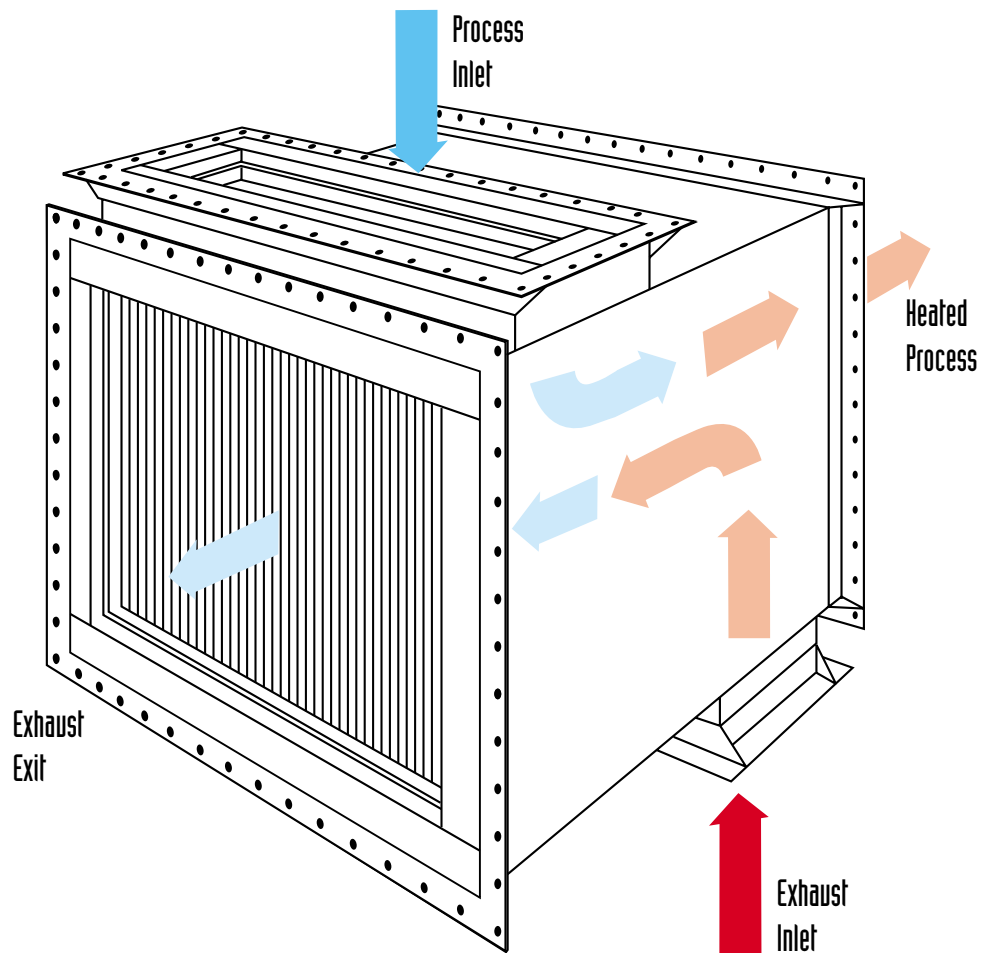

ISO 9001 Registered Quality System



**Exothermics, Inc.**  
A Subsidiary of Eclipse, Inc.

## Represented By:

Power Equipment Company  
2011 Williamsburg Road  
Richmond, VA 23231  
804-236-3800  
Fax: 804-236-3882  
[www.peconet.com](http://www.peconet.com)

Copyright 1997 Exothermics-Eclipse, Inc. Our policy of continuous product improvement requires Exothermics, Inc. to reserve the right to change or alter design or specifications without notice. Exothermics, Inc. patents #4,131,159, #4,529,212, #4,541,480, #4, 852,640.