

## Installation, Operation and Maintenance Manual Series B3 ROOTS® Meters

**Models:**

**Series B3:**

**8C175 -56M175**

**Series B3-HP:**

**IM300 - 3M300**



## **WARRANTY**

Seller warrants that (i) its products will, at the F.O.B. point, be free from defects in materials and workmanship and (ii) its services will, when performed, be of good quality.

Any claim for failure to conform to the above and foregoing warranty must be made immediately upon discovery, but in any event, within eighteen (18) months following delivery of the specified product at the F.O.B. point or twelve (12) months after installation whichever is earlier, or twelve (12) months after performance of the specified services. Warranties may be extended in time pursuant to Seller's written warranties, provided payment has been received for the extension. Defective and nonconforming items must be held for Seller's inspection and returned at Seller's request, freight prepaid, to the original F.O.B. point.

Upon Buyer's submission of a claim as provided above and substantiation, Seller shall, at its option (i) either repair or replace its nonconforming product or correct or reperform its nonconforming services, as applicable, or (ii) refund an equitable portion of the purchase price attributable to such nonconforming products or services. Seller shall not be liable for the cost of removal or installation of materials or any unauthorized warranty work, nor shall Seller be responsible for any transportation cost, unless expressly authorized in writing by Seller. Any products or materials replaced by Seller will become the property of Seller. Repair or replacement of products, or correction or reperformance of services, or refund of an equitable portion of the purchase price shall be Seller's only obligation and the sole and exclusive remedy of Buyer in the event of a failure to conform to the foregoing warranty.

THE FOREGOING WARRANTY IS EXCLUSIVE AND IN LIEU OF ALL OTHER WARRANTIES (EXCEPT THAT OF TITLE) EXPRESS OR IMPLIED, INCLUDING, BUT NOT LIMITED TO THE IMPLIED WARRANTIES OF MERCHANTABILITY AND FITNESS FOR A PARTICULAR PURPOSE.



**ROOTS Meters and Instruments**  
**Dresser, Inc.**

## TABLE OF CONTENTS

|   |              |  |              |
|---|--------------|--|--------------|
| <b>WARRANTY</b>   | <b>2</b>     | <b>ACCESSORY UNIT REMOVAL &amp; CONVERSION PROCEDURES</b>  | <b>17-23</b> |
| <b>TABLE OF CONTENTS</b>  | <b>3</b>     | <ul style="list-style-type: none"><li>• Removing the Accessory Unit</li><li>• Removing the Gear Reduction</li><li>• Replacing the Gear Reduction</li><li>• Installing the Accessory Unit</li><li>• ID Side Inlet to Top Inlet Conversion</li><li>• Changing the ID Rotational Direction</li><li>• Installing a Solid State Pulser</li><li>• Installing an ICEX</li><li>• Installing an AMR Adapter</li></ul> |              |
| <b>RECEIVING, HANDLING &amp; STORAGE</b>  | <b>4</b>     |  |              |
| <b>INTRODUCTION</b>   | <b>4-5</b>   |  |              |
| <ul style="list-style-type: none"><li>• Use and Limitations</li><li>• Operating Principle</li></ul>   |              |  |              |
| <b>GENERAL DESIGN CHARACTERISTICS</b>   | <b>5</b>     | <b>TESTING</b>   | <b>23-29</b> |
| <b>METER BODY</b>   | <b>5</b>     | <ul style="list-style-type: none"><li>• General</li><li>• Differential Test</li><li>• Establishing Baseline Curves</li><li>• Differential Test Procedure</li><li>• Proving Operations</li><li>• TC Unit Operational Check</li><li>• Procedure for the TC Unit Operational Check</li><li>• Calculating Theoretical Counts</li></ul>   |              |
| <b>ACCESSORY UNIT</b>   | <b>6-10</b>  | <b>TROUBLE SHOOTING CHECKLIST</b>  | <b>29</b>    |
| <ul style="list-style-type: none"><li>• Counter (CTR)</li><li>• Counter with Instrument Drive (CD)</li><li>• Temperature Compensated (TC)</li><li>• Temperature Compensated with Instrument Drive (TD)</li><li>• Pulser Version</li><li>• Counter with Electronic Transmitter (ICEX)</li><li>• Counter/TC AMR (Automatic Meter Reading) version</li></ul> |              | <b>SIZING CHARTS</b>   | <b>30-31</b> |
| <b>IMPERIAL/METRIC ODOMETERS</b>  | <b>11</b>    |  |              |
| <b>TEST WHEEL</b>   | <b>12</b>    |  |              |
| <b>TC ODOMETER</b>  | <b>12</b>    |  |              |
| <b>METER INSTALLATION</b>   | <b>12-16</b> |  |              |
| <ul style="list-style-type: none"><li>• Piping Configurations</li><li>• Placing Meter In Line</li><li>• Oil Capacities</li><li>• Meter Start-Up</li></ul>   |              |  |              |
| <b>INSPECTION &amp; MAINTENANCE</b>   | <b>16</b>    |  |              |
| <ul style="list-style-type: none"><li>• Accessory Unit</li><li>• Lubrication</li><li>• Meter Level</li><li>• Meter Testing</li><li>• Cleaning and Flushing</li></ul>  |              |  |              |

## AT TIME OF DELIVERY

1. Check the packing list to account for all items received.
2. Inspect each item for damage.
3. Record any visible damage or shortages on the delivery record.
  - File a claim with the carrier.
  - Notify your ROOTS® meter supplier immediately.

**Do not accept any shipment that has evidence of mishandling in transit without making an immediate inspection of package for damage. All new meters should be checked for free rotation soon after arrival as damage to internal working parts can exist without obvious external evidence.**

Should any serious problems be encountered during installation or initial operation of the meter, notify your ROOTS® meter supplier immediately.

**Do not attempt repairs or adjustments, as doing so may be a basis for voiding all claims for warranty.**

When reporting a suspected problem, please provide the following information:

- Your Purchase Order Number and/or Dresser's Sales Order Number
- The Meter Model, Serial Number and Bill of Material Number

(This information can be located on the blue name plate that is between the differential plugs on the meter body)

- The Accessory Unit Serial Number
- A Description of the problem
- Application information, such as gas type, pressure, temperature, and flow characteristics

Our Product Services Department offers professional services for all ROOTS® products. Authorization for return is required for all products shipped to the Factory for repair, calibration, warranty, exchange or credit. To obtain authorization an RMA number for return of ROOTS® products must be issued. Please contact your ROOTS® meter supplier. All returns should be packaged in an original-type shipping container if available or shipping material that will protect the product. Note: Do not use peanut packing foam because fragments may enter the measuring chamber.

## STORAGE/INITIAL TESTING

If the meter is not tested or installed soon after receipt, store in a dry location in the original shipping container for protection. Make sure the box remains horizontal with the arrow pointing up. Leave the protective caps installed in the meter. The caps will provide reasonable protection against dust.

“Checking for free rotation” (Refer *Figure 12*) does not necessarily mean the meter will pass a test after sitting on the shelf for a year or two. A small amount of oil is applied to the bearings of new or remanufactured meters, but this is only sufficient for factory testing. The oil in the bearings can coagulate over time. This condition may impact meter test performance until the bearings loosen up. Dresser recommends a drop or two of oil be applied to each bearing and that the meter be run at a flow rate between 80% & 100% of meter capacity for two minutes or until the meter is running smoothly.

## INTRODUCTION

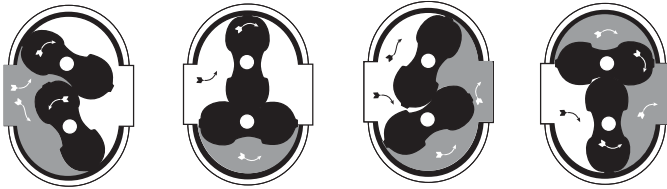
### Use and Limitations

ROOTS® Meters are suitable for handling most types of clean, dry, common gases at either constant or varying flow rates. The meter is not suitable for handling liquids. Measurement accuracy and life expectancy may be affected by dirt or other types of foreign material in the gas stream.

Meters of standard construction are not suitable for handling acetylene, biogas or sewage gas. Specially constructed meters compatible with these and other gases are available. Please contact your ROOTS® meter supplier for details and to request publication TS:SSM.

## Operating Principle

As shown in *Figure 1*, two contra-rotating impellers of two-lobe or “figure 8” contour are encased within a rigid measuring chamber, with inlet and outlet connections on opposite sides. Precision machined timing gears keep the impellers in correct relative position. Optimal operating clearances between the impellers, cylinder, and headplates provide a continuous, non-contacting seal.



**Figure 1 - Impellers rotating inside meter cylinder.**

Because of this design, the gas at the meter’s inlet is effectively isolated from the gas at the outlet. During impeller rotation, the precision machined measuring chamber traps a known volume of gas between the impeller and the adjacent cylinder wall. The meter will measure and pass four equal gas volumes with each complete revolution of the impellers.

The sum total of the four volumes is the “volume per revolution”. The volume is indicated in Engineering units represented in cubic feet (or cubic meters).

Volumetric accuracy of the ROOTS® meter is permanent and non-adjustable. Measurement characteristics are established by the shape and the precise machining of non-wearing fixed and rotating parts.

A meter’s rated capacity is the maximum flow rate at which the meter may be operated and is determined by the dynamic loads acting on the moving parts of the meter. These loads are primarily related to meter RPM, and secondarily to the metering pressure. The standard volume capacity of a rotary meter increases directly with changes in absolute line pressure and inversely with changes in absolute line temperature.

## GENERAL DESIGN CHARACTERISTICS

ROOTS® Meters are manufactured in accordance with the American National Standard specification ANSI/ASC-B109.3 for Rotary Type Gas Displacement Meters. The flanged inlet and outlet connections conform dimensionally to ANSI/ASME standard B16.5. The operating temperature range is from -40°F to +140° F (-40° C to +60° C).

Every meter is static pressure tested at the factory at 200% of its MAOP (Maximum Allowable Operating Pressure) and leak tested at 125% of MAOP in accordance with ASME Boiler and Pressure Vessel Codes. The internal aluminum parts of the measurement chamber (i.e., impellers and headplates) are hard-coat anodized for added corrosion and abrasion resistance. The external surface and the two end covers are clear coat anodized.

The meter rating is expressed in hundreds (C) or thousands (M) of Actual Cubic Feet per Hour (ACFH), or in Cubic Meters per Hour (m³H). Actual displaced volume measurement is completely independent of the gas specific gravity, temperature, and pressure and can be easily converted to volume at Standard conditions for elevated pressure and varying temperature by application of the Gas Laws (reference Dresser publication RM-135).

Refer to a meter sizing chart for capacity ratings at elevated line pressures or varying line pressures since this will assist in properly sizing the meter.

## METER BODY

| Meter Size  | Operating Pressures    | Connection Types ANSI Class |
|-------------|------------------------|-----------------------------|
| 8C -56M*    | 175 PSIG<br>(1200 kPa) | 150# FF                     |
| 23M232      | 232 PSIG<br>(1600 kPa) | 150# FF                     |
| 1M300/3M300 | 300 PSIG               | 300 # FF                    |

\* Upon special request:

Meter sizes 8C through 2M are available with 1-1/2" NPT nipped connections.

Sizes 8C through 5M are available with a MAOP rating of 200 PSIG (1380 kPa).

Major components of these meters are machined from cast or extruded aluminum for a combination of strength and weight reduction.

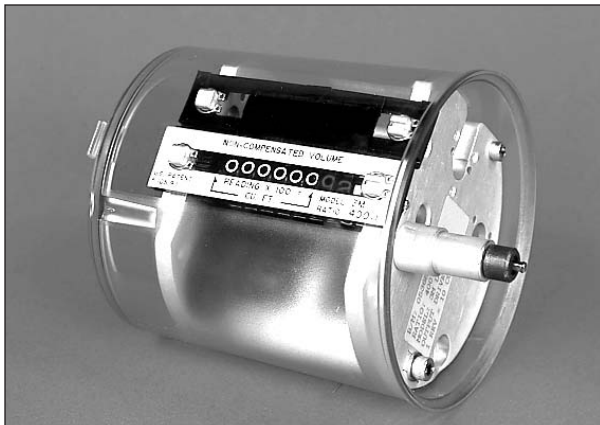
## ACCESSORY UNIT

Totalization of the volume is performed by a magnetically coupled gear reduction unit referred to as the Series 3 Accessory Unit. These units are permanently lubricated for long life and maintenance-free operation. They register displaced volume in actual cubic feet (ACF) or actual cubic meters (m<sup>3</sup>). The Series 3 Accessory Unit is isolated from the pressure vessel and is not pressurized. This modular design allows interchangeability of Accessory Units on Series B meter bodies of the same size.

### Counter (CTR) Version

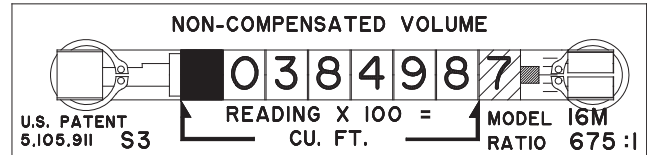
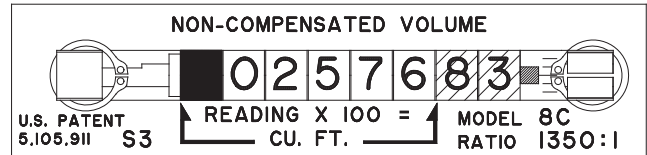
The Series 3 CTR units register volume in actual cubic feet (ACF) or actual cubic meters (m<sup>3</sup>) on an 8 digit odometer. The Series 3 CTR cover is molded of optical quality Lexan<sup>®</sup> with a quad ring seal. The cover's smooth cylindrical design easily sheds rain and resists accumulations of snow, ice and dirt.

**NOTE:** Reference the "Reading the Odometer" section for instructions on reading the Series 3 Accessory Unit.



**Figure 2** - Series 3 Accessories do not require oil. (CTR Version shown)

The 8C through 11M odometers with Imperial units of measure (actual cubic feet) have five exposed digits. As an industry standard, the first digit on the left of the odometer is typically concealed with an opaque mask. Translucent masks are normally specified to cover the two right-most digits. For the 16M through 56M odometers with Imperial units, six digits are exposed. Again, the first digit on the left of the odometer is typically concealed with an opaque mask while only the right-most digit is covered with a translucent mask. The odometers for 8C and 16M meters are shown in Figure 3.



**Figure 3** - Non-Compensated Series 3 Imperial unit odometer for 8C (Top) and 16M (Bottom).

### Counter with Instrument Drive (CD) Version

The Counter with Instrument Drive (CD) unit uses the CTR assembly above, with a specially designed Lexan<sup>®</sup> cover and an Instrument Drive support assembly. The Instrument Drive (ID) support is mechanically linked to the gear reduction of the CTR unit and rotates the instrument 'drive dog' at the ID output. One revolution of the instrument drive dog represents a specific displaced volume measured by the meter, depending upon meter size. Refer to Table 1 for Instrument Drive Rates for that particular meter size.

Lexan<sup>®</sup> is a registered trademark of the General Electric Company.

|                 | Meter Size   | Volume/Revolution         |
|-----------------|--------------|---------------------------|
| <b>Imperial</b> | 8C thru 11M  | 10 cu. ft./rev.           |
|                 | 16M thru 56M | 100 cu. ft./rev.          |
| <b>Metric</b>   | 8C thru 3M   | 0,1 m <sup>3</sup> /rev.  |
|                 | 5M thru 38M  | 1,0 m <sup>3</sup> /rev.  |
|                 | 56M          | 10,0 m <sup>3</sup> /rev. |

**Table 1** - Instrument Drive Rates for Series 3 Counter with Instrument Drive (CD) accessories.

The instrument mounting section of the Instrument Drive (ID) housing can be easily rotated 90° when changing the meter from Top to Side inlet or vice versa. (Refer to "ACCESSORY UNIT REMOVAL & CONVERSION PROCEDURES, Side Inlet to Top Inlet Conversion".) A cover plate on the Instrument Drive support housing allows access to the bevel gears for a change of rotation of the drive dog - from clockwise to counterclockwise rotation or vice versa. (Refer to "ACCESSORY UNIT REMOVAL & CONVERSION PROCEDURES, Changing the Rotational Direction).

of the Instrument Drive”.) A decal located on the ID housing indicates output drive volume. There is also a universal instrument mounting plate installed on the ID support.

**NOTE:** Lubrication is NOT required for the ID support housing.

**Temperature Compensated (TC) Version**

Temperature compensation is accomplished by a mechanical computational device with a bi-metallic probe located in a sealed temperature well at the meter inlet. This system allows Series 3 Temperature Compensated (TC) units to provide corrected volume readings on gas temperatures ranging from -20°F to +120°F (-29°C and +49°C).

**NOTE:** Temperature compensated meters update the temperature compensated odometer intermittently.

All standard design 8C175 through 16M175 and 8C200 through 5M200 Series B meter bodies are shipped with a temperature probe well installed. This allows for an easy and low cost conversion from a non-compensated meter to temperature compensated meter.

**NOTE:** Reference the “READING THE ODOMETER” section for instructions on reading the Series 3 Accessory Unit.

**Temperature Compensated with Instrument Drive (TD) Version**

The Temperature Compensated with Instrument Drive (TD) Accessory Unit uses a standard TC unit with an Instrument Drive (ID) support installed. However, one revolution of the ‘drive dog’ now represents a gas volume corrected to a contract Base temperature of 60°F (or 15°C). The drive rates are provided in *Table 2*.

**NOTE:** Rotation of the “Drive Dog” is tied directly to the update of the compensated odometer and is therefore, intermittent in nature.

|                 | Meter Size  | Volume/Revolution |
|-----------------|-------------|-------------------|
| <b>Imperial</b> | 8C thru 11M | 100 cu. ft./rev.  |
|                 | 16M         | 1000 cu. ft./rev. |
| <b>Metric</b>   | 8C thru 3M  | 1 m³/rev.         |
|                 | 5M thru 16M | 10 m³/rev.        |

**Table 2 - Instrument Drive rates for Series 3 Temperature Compensated Accessory Unit with Instrument Drive (TD).**

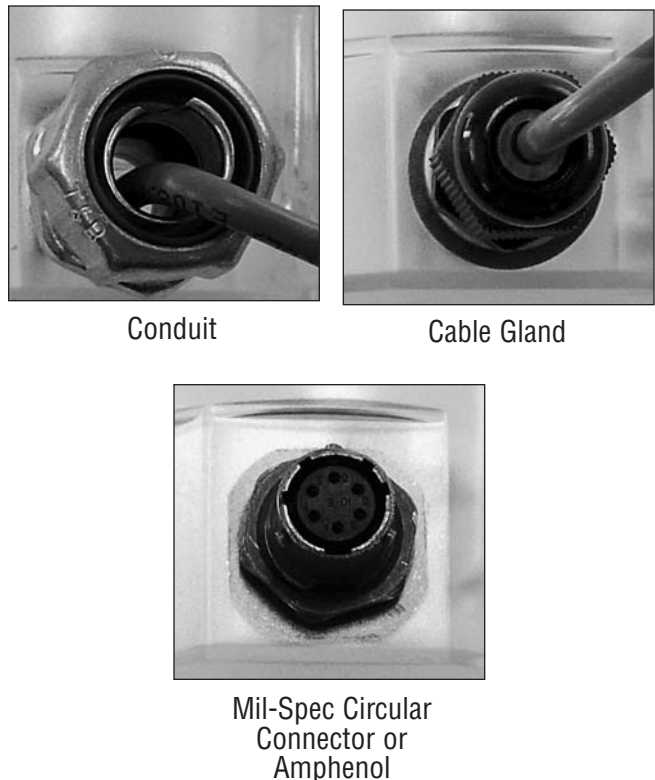
**Pulsar Version**

ROOTS® Pulsers generate low frequency pulses for remote volume data collection. Pulsers are available with Single or Dual Mil-Spec (MS) circular connectors, a liquid tight conduit fitting, or a cable gland connection as shown in *Figure 4*.

The CTR unit’s output represents Non-Compensated volume only. The TC unit provides two outputs; one representing non-compensated volume, the second representing temperature compensated volume.

The pulse rate for any factory installed accessory unit can be identified by the decal located on the Pulsar’s Lexan® cover or by referencing *Table 3*. The temperature, electrical and current rating is located on another label which is also on the Lexan® cover. *Table 4* provides the wiring guide for series 3 Pulsers.

For additional information, request Pulsar specification sheet TS:SSP and drawing number 057159-000.



**Figure 4 - Pulsar Connector Versions**

**Table 3 - The Pulse Outputs for Series 3 Pulsers**

| Series B Meter Size | Series 3 Accessory | Imperial (Cubic Feet) Non-Compensated | Imperial (Cubic Feet) Compensated | Metric (Cubic Meter) Non-Compensated |
|---------------------|--------------------|---------------------------------------|-----------------------------------|--------------------------------------|
| 8C-3M               | CTR                | 10 cf                                 | —                                 | 0,1 m <sup>3</sup>                   |
| 5M-11M              | CTR                | 10 cf                                 | —                                 | 1,0 m <sup>3</sup>                   |
| 16M-38M             | CTR                | 100 cf                                | —                                 | 1,0 m <sup>3</sup>                   |
| 56M                 | CTR                | 100 cf                                | —                                 | 10,0 m <sup>3</sup>                  |
| 8C-3M               | TC                 | 10 cf                                 | 10 cf*                            | 0,1 m <sup>3</sup>                   |
| 5M-11M              | TC                 | 10 cf                                 | 10 cf*                            | 1,0 m <sup>3</sup>                   |
| 16M                 | TC                 | 100 cf                                | 100 cf*                           | 1,0 m <sup>3</sup>                   |

**Table 4 - The Wiring Guide for Series 3 Pulsers**

| Pulser Type | Pulser Connection Type                            | Non-Compensated Signal |        |                 | Temperature Compensated Signal |        |                 |
|-------------|---|------------------------|--------|-----------------|--------------------------------|--------|-----------------|
|             |   | Normally Open (Signal) | Common | Normally Closed | Normally Open (Signal)         | Common | Normally Closed |
| ICPWS MSC   | MS Style Circular Connection                      | A                      | B      | C               | —                              | —      | —               |
| ICPWD MSC   | Two MS Style Circular Connections                 | A                      | B      | C               | —                              | —      | —               |
| ICPWS CBG   | Cable Gland with Leads (Pig Tail)                 | Brown                  | Green  | Red             | —                              | —      | —               |
| ICPWD CBG   | Two Cable Glands with Leads (Pig Tail)            | Brown                  | Green  | Red             | —                              | —      | —               |
| ICPWX CND   | Conduit Compression Coupling with Lead (Pig Tail) | Brown                  | Green  | Red             | —                              | —      | —               |
| ITPWS MSC   | MS Style Circular Connection                      | A                      | B      | C               | D                              | E      | F               |
| ITPWD MSC   | Two MS Style Circular Connections                 | A                      | B      | C               | D                              | E      | F               |
| ITPWS CBG   | Cable Gland with Leads (Pig Tail)                 | Brown                  | Green  | Red             | White                          | Black  | Blue            |
| ITPWD CBG   | Two Cable Glands with Leads (Pig Tail)            | Brown                  | Green  | Red             | White                          | Black  | Blue            |
| ITPWX CND   | Conduit Compression Coupling with Lead (Pig Tail) | Brown                  | Green  | Red             | White                          | Black  | Blue            |



### Counter with Electronic Transmitter (ICEX) Version

Like the ROOTS® Solid State Pulsers, ICEX Meters (Integral Counters with Electronic Transmitters) have a magnetically driven Pulser inside the cover. It generates a single channel high frequency pulse. This allows for remote collection of volume while also providing a pulse rate suitable for determination of flow rate. Pulse rates for various meter sizes are shown in *Table 6*.



**Figure 5 - Series 3 ICEX**

The ICEX is available with a Single MS style circular connector, a liquid tight conduit fitting, or a cable gland connection (As shown previously in *Figure 4*). *Table 5* provides wiring information for the ICEX.

**NOTE:** As the magnet rotates on the high speed shaft, a sensor within the ICEX housing detects a change in the magnetic field.

**Table 5 - Wiring guide for Series 3 ICEX.**

| ICEX Connection Type         | Normally Open (Signal) | Common |
|------------------------------|------------------------|--------|
| MS Style Circular Connection | A                      | B      |
| Conduit with Leads           | White                  | Black  |
| Cable Gland with Leads       | White                  | Black  |

**Table 6 - Pulse outputs for ICEX Accessory Units in relation to meter sizes.**

| Meter Type | Freq. (Hz) | Volume per Pulse |             | Pulses per Volume* |       | Flow Rate (ACFH) |
|------------|------------|------------------|-------------|--------------------|-------|------------------|
|            |            | (CF)             | (m³)        | (CF)               | (m³)  |                  |
| 8C175      | 120        | 0.001852         | 0,000052439 | 540                | 19070 | 800              |
| 11C175     | 146.67     | 0.002083         | 0,000058993 | 480                | 16951 | 1,100            |
| 15C175     | 166.67     | 0.002500         | 0,000070792 | 400                | 14126 | 1,500            |
| 2M175      | 111.11     | 0.005000         | 0,000141584 | 200                | 7063  | 2,000            |
| 3M175      | 133.33     | 0.006250         | 0,000176980 | 160                | 5650  | 3,000            |
| 5M175      | 150.00     | 0.009259         | 0,000262193 | 108                | 3814  | 5,000            |
| 7M175      | 124.45     | 0.015625         | 0,000442451 | 64                 | 2260  | 7,000            |
| 11M175     | 122.22     | 0.025000         | 0,000707921 | 40                 | 1413  | 11,000           |
| 16M175     | 120.00     | 0.037037         | 0,001048772 | 27                 | 953   | 16,000           |
| 23M232     | 127.78     | 0.050000         | 0,001415843 | 20                 | 706   | 23,000           |
| 23M175     | 69         | 0.092593         | 0,002621931 | 10.8               | 381   | 23,000           |
| 38M175     | 76         | 0.138889         | 0,003932896 | 7.2                | 254   | 38,000           |
| 56M175     | 89.60      | 0.173611         | 0,004916120 | 5.8                | 203   | 56,000           |
| 1M300      | 55.55      | 0.005000         | 0,000141584 | 200                | 7063  | 1,000            |
| 3M300      | 133.33     | 0.006250         | 0,000176980 | 160                | 5650  | 3,000            |
| 1M740      | 75.00      | 0.003704         | 0,000104877 | 270                | 9535  | 1,000            |
| 3M740      | 166.67     | 0.005000         | 0,000141584 | 200                | 7063  | 3,000            |
| 1M1480     | 75.00      | 0.003704         | 0,000104877 | 270                | 9535  | 1,000            |
| 3M1480     | 166.67     | 0.005000         | 0,000141584 | 200                | 7063  | 3,000            |
| 5M1480     | 100.00     | 0.013889         | 0,000393290 | 72                 | 2543  | 5,000            |
| 7M1480     | 124.45     | 0.015625         | 0,000442451 | 64                 | 2260  | 7,000            |

\* Pulse per volume rounded to nearest whole number. For calculation purposes, use volume per pulse.

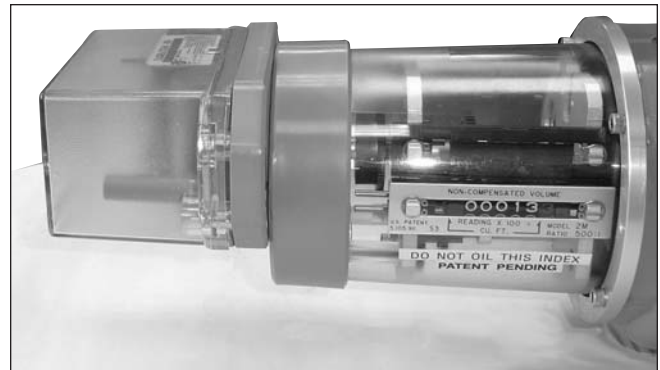
## Counter/TC Automatic Meter Reading (AMR) Adapter Version

This design utilizes a Series 3 Lexan® cover with an opening to engage the residential AMR module in a direct drive link to the gear reduction unit. The direct drive AMR Adapter offers a solution for Series B3 CTR or TC meters in applications that require the adaptation of a residential style AMR. The AMR Adapter is available as a conversion kit for field installation or can be factory installed on the Series B3 ROOTS® Meter.

The AMR Adapter consists of a Lexan cover, an adapter “puck” (with coupling), an adapter plate and a drive dog. It is universal up to the adapter plate and drive dog, which are specific for the residential meter type AMR device to be mounted (American or Invesys/Sensus/Rockwell) and the type of AMR module being used (Itron, Badger, Trace, Cellnet, etc.) Programming Rates for various meter sizes are shown in *Table 7*.



**Figure 6** - American & Invesys Footprint AMR Adapters



**Figure 7** - American Footprint AMR Adapter installed on a 2M ROOTS Meter (shown with Residential ERT attached).

**Table 7** - S3 Meter Drive Rates for Direct Drive AMR Programming

| Meter Size | CTR Meter Drive Rate<br>cu. ft./rev. | TC Meter Drive Rate<br>cu. ft./rev. |
|------------|--------------------------------------|-------------------------------------|
| 8C175      | 10                                   | 100                                 |
| 11C175     | 10                                   | 100                                 |
| 15C175     | 10                                   | 100                                 |
| 2M175      | 10                                   | 100                                 |
| 3M175      | 10                                   | 100                                 |
| 5M175      | 10                                   | 100                                 |
| 7M175      | 10                                   | 100                                 |
| 11M175     | 10                                   | 100                                 |
| 16M175     | 100                                  | 1000                                |
| 23M175     | 100                                  | N/A                                 |
| 38M175     | 100                                  | N/A                                 |
| 56M175     | 100                                  | N/A                                 |

## READING THE ODOMETER

### IMPERIAL ODOMETERS

As an industry standard, the first digit on the left of the odometer is typically concealed with an opaque (black) mask. Translucent (see through) blue masks typically cover any digits to the right that represent less than 100 cubic feet.

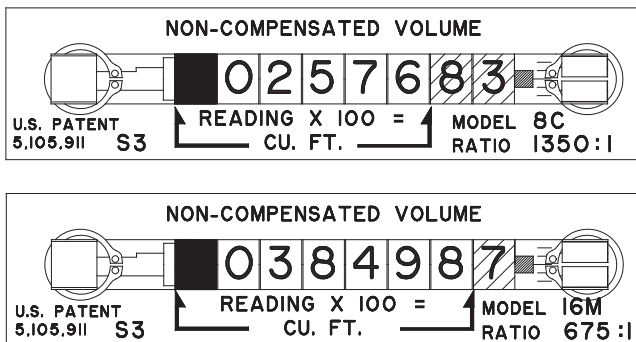
When reading an 8C through 11M odometer (*Figure 8a*), the five exposed digits “02576” between the arrows on the nameplate are typically multiplied by 100, to read volume in hundreds of cubic feet or 257600 cubic feet.

**NOTE:** If the last two digits “83” to the right of the arrows were included in the reading, the odometer in Figure 8a would indicate a volume of 257683 cubic feet.

For the 16M through the 56M sizes (*Figure 8b*), the six exposed digits (38498) between the arrows on the nameplate are typically multiplied by 100 to read the volume in hundreds of cubic feet or 3849800 cubic feet.

**NOTE:** If the last digit “7” to the right of the arrows were included in the reading, the odometer in Figure 7a would indicate a volume of 3849870 cubic feet.

**NOTE:** Some customers will special order Accessory Units with a multiplication factor of 1000. Verify that the marking between the arrows on the Accessory Unit nameplate for that particular unit indicates the correct multiplier, (i.e. “Reading X 100 Cu. Ft.” as explained previously, or “Reading X 1000 Cu. Ft.”)



**Figure 8 - Non-Compensated Series 3 Imperial unit odometer for 8C (8a Top) and 16M (8b Bottom).**

### METRIC ODOMETERS

Examples of metric odometers are shown in *Figure 9*. - Non-Compensated Series 3 Metric Unit odometers for 8C (Top), 16M (Middle), and 56M (Bottom).

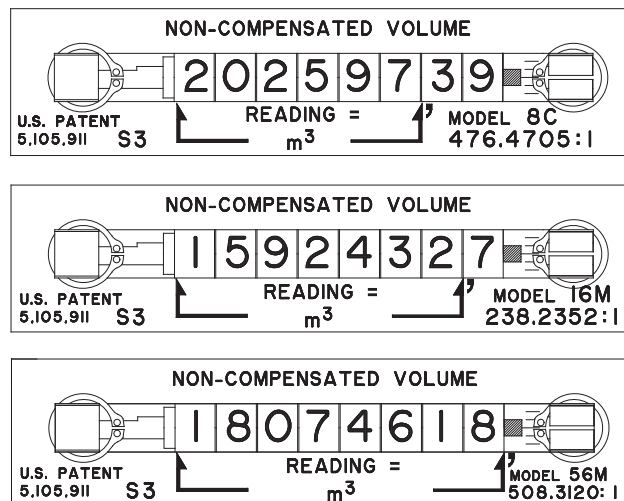
When reading an 8C through 3M odometer (*Figure 9a*), the six digits between the arrows on the nameplate “202597” are equal to cubic meters.

**NOTE:** If the last two digits “39” to the right of the comma were included in the reading, the odometer in Figure 9a would indicate a volume of 202597,39 cubic meters.

For the 5M through the 38M sizes (*Figure 9b*), the seven digits between the arrows on the nameplate “1592432” are equal to cubic meters.

**NOTE:** If the last digit “7” to the right of the comma were included in the reading, the odometer in Figure 9b would indicate a volume of 1592432.7 cubic meters.

On the 56M metric meter (*Figure 9c*), all of the odometer digits are between the arrows and are read as cubic meters. The decimal point (comma) is shown just before the graduated increments on the test wheel. A reading of 18074618 is literally 18074618 cubic meters.



**Figure 9 - Non-Compensated Series 3 Metric Unit odometers for 8C (9a Top), 16M (9b Middle), and 56M (9c Bottom).**

## TEST WHEEL

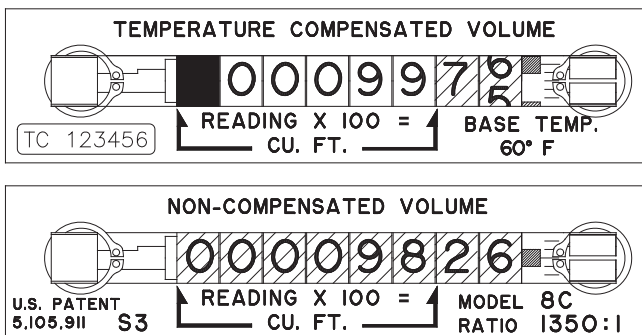
The index wheel numbers on the odometer have 10 divisions marked that range from 0 through 9 located on the right side of the odometer. The graduated increments on the test wheel represent 0.2 cubic feet for the 8C through 11M meters and 2 cubic feet for the 16M through 56M meters. This allows for accurately estimating readings of 0.1 cubic feet and 1 cubic foot, respectively. For metric versions, the graduated increments on the test wheel represent 0,002 cubic meters for the 8C through 3M meters, 0,02 cubic meters for the 5M through 38M meters, and 0,2 cubic meters for the 56M. This allows for accurately estimated readings of 0,001 cubic meters, 0,01 cubic meters, and 0,1 cubic meters respectively.

Whether imperial or metric, the white reflective marks that are located to the left of the graduated increments are used for prover testing with an optical photo-sensor (scanner).

## TC ODOMETERS

As shown in *Figure 10*, the TC unit has two digital odometers. The top odometer represents the Temperature Compensated volume corrected to a contract Base temperature of 60° F (or 15° C). This top odometer can be read in a similar fashion to the uncorrected odometers as shown in *Figures 8 and 9*.

The bottom odometer is Non-Compensated and is typically covered with a translucent mask to reduce readability and/or prevent misreading. An optional black mask can be specified to completely prevent viewing of the non-compensated odometer. Other masking configurations are available upon request.



**Figure 10** - Temperature compensated Accessory Units have two odometers for a temperature compensated reading on top and a non-compensated reading on the bottom.

## METER INSTALLATION

### Piping Configurations

Series B3 and B3-HP meters can be installed in either a Top Inlet (vertical gas flow) or a Side Inlet (horizontal gas flow) configuration as shown in *Figures 11 and 12* respectively. The preferred installation is top inlet in a vertical pipeline with gas flowing downward. Although the design of the impellers tends to make the meter self-cleaning, top inlet mounting enhances the ability to pass dirt, pipe scale, or other debris through the meter.

Piping should be rigid and properly aligned. The meter does not require any direct means of support. However, the piping might need support to eliminate any piping strains which may cause the meter to bind.

Another recommendation is to install the meter with a bypass adjacent to the main line. Additionally, the installation of tees upstream and downstream of the meter will help facilitate transfer proving or other types of testing with the meter still mounted in the pipeline.

Do not install the meter lower than the discharge pipe run to avoid accumulation of condensate or foreign materials in the metering chamber. Use a Gasket style, Y-type, or some other kind of strainer upstream of the meter to help remove foreign matter (pipe sealant, tape, weld slag, etc.) from the gas stream. A 100 Mesh screen is recommended for any strainer used.

The installation of a lubricated gas valve directly before a meter is not recommended, as excess valve lubricant may stop impeller rotation.

If over-speed conditions could occur, a restricting flow orifice plate should be installed 2 to 4 pipe diameters downstream of the meter outlet. Contact the factory or your Dresser representative for sizing, pricing and availability.

**NOTE:** Warranty does not cover meter failure due to over-speed conditions.

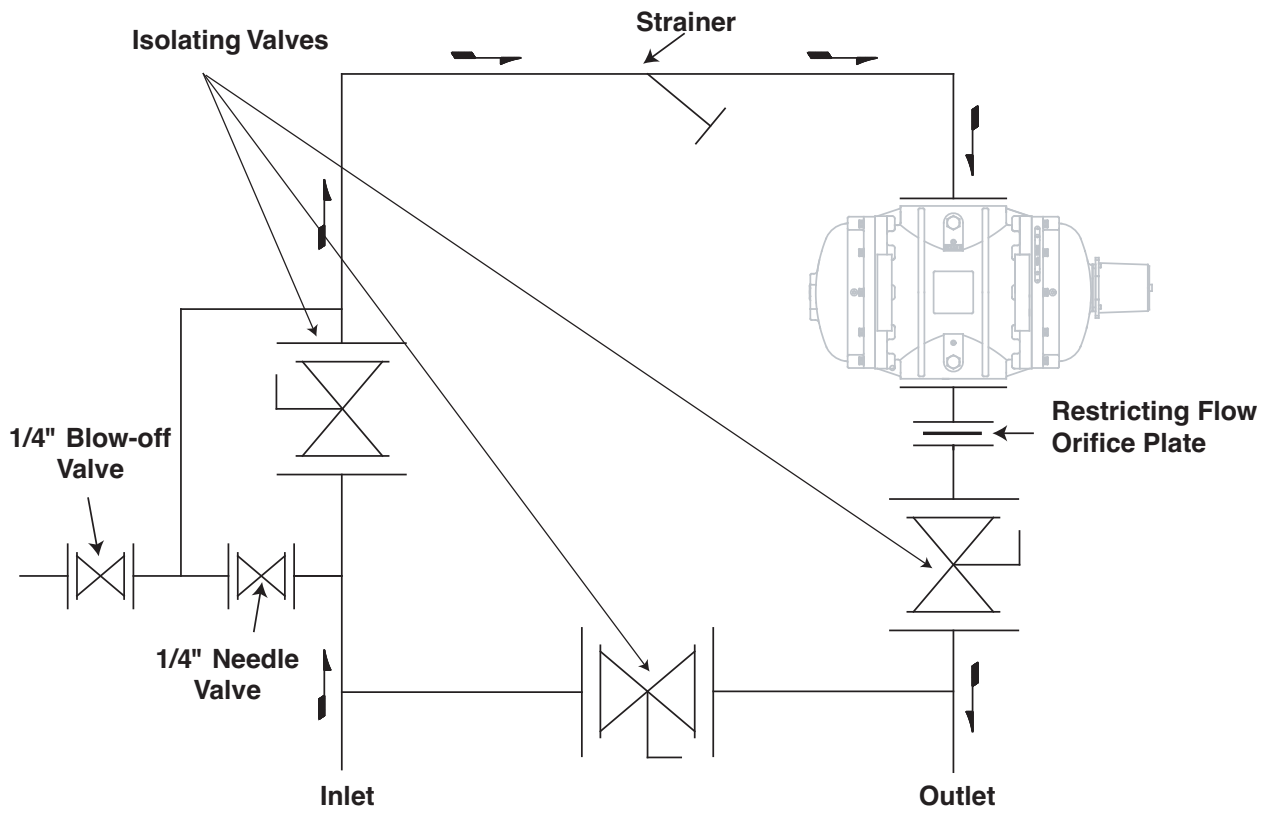


Figure 11 - Top Inlet Configuration for Series B3 Meter.

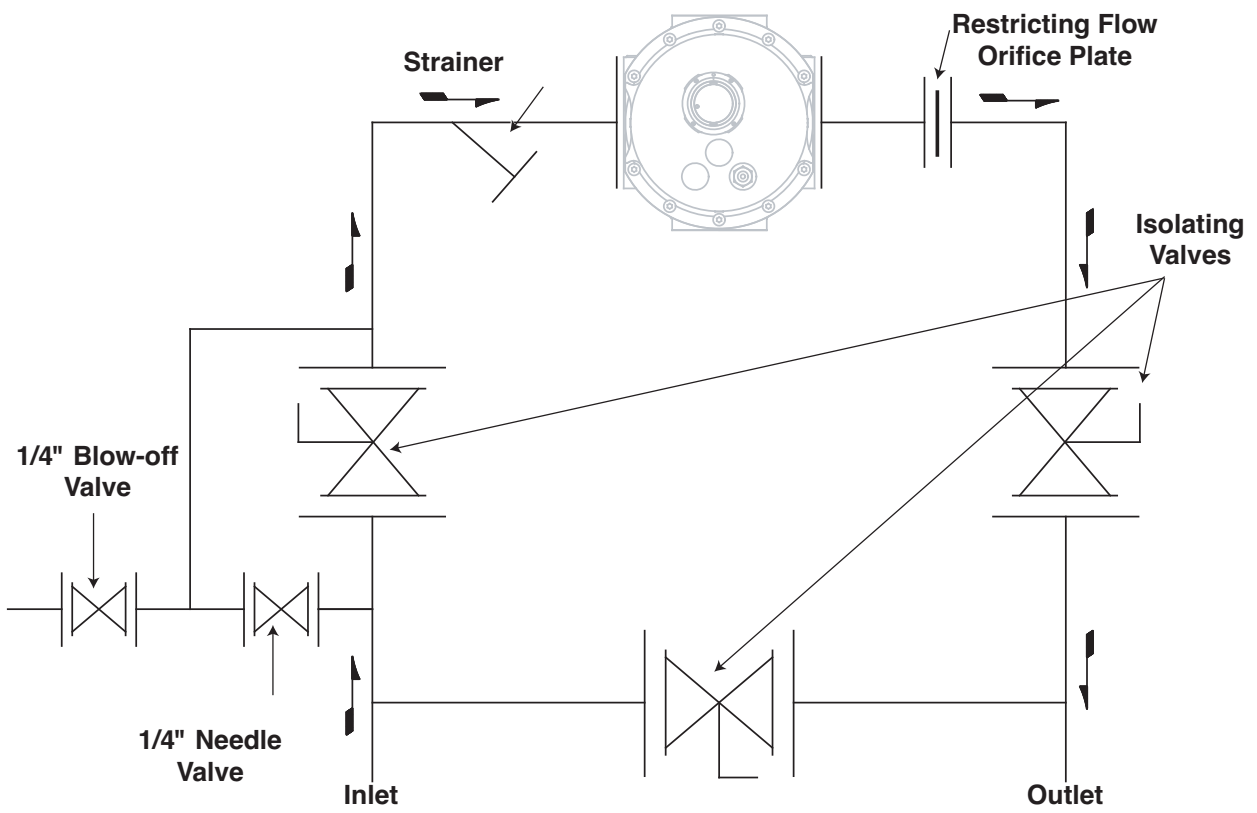


Figure 12 - Side Inlet Configuration for Series B3 Meter.

## Placing Meter In Line

**IMPORTANT:** Do not fill meter end cover oil reservoirs until after the meter has been permanently installed and is ready for service. (Refer to *Figure 14* for oil reservoir locations).

- Before installing a meter:
  - Make sure the upstream piping is clean. During this procedure, use extreme caution and follow recommended company procedures.
  - Remove the plastic protective caps from both meter flanges prior to meter installation.
  - Ensure the impellers turn freely and no objects or contaminants are in the measuring chamber.
- Meter Orientation:
  - Connect meter inlet to the gas supply side of the line.
  - In a correct meter installation, the counter and gear end oil level gauges are parallel to the ground.

**IMPORTANT:** The arrow on the name plate **MUST** represent the direction of flow of gas through the meter

- Install the meter without piping strain to prevent binding of the impellers and use the proper pipe supports if required. Level all meters to within 1/16" per running foot (5 mm/m), side-to-side and front-to-back for proper alignment.
- Tighten flange bolts evenly in a cross-pattern. The maximum recommended torques are provided in *Table 8*.

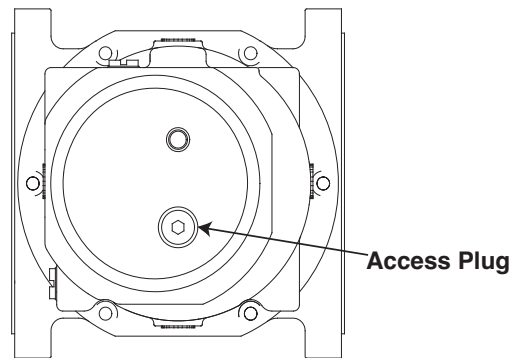
| Meter Size    | Bolt Diameter | Torque (ft-lbs) |                 |
|---------------|---------------|-----------------|-----------------|
|               |               | Lubricated      | Non-Lubricated  |
| 8C175-16M175  | 5/8"          | 55              | Not recommended |
| 23M232        | 5/8"          | 55              |                 |
| 23M175-56M175 | 3/4"          | 80              |                 |
| 1M300         | 3/4"          | 80              |                 |
| 3M300         | 5/8"          | 80              |                 |

**Table 8 - Recommended Flange Bolt Torques**

**CAUTION:** The meter must **NOT** be under pressure for this procedure.

- After the meter has been installed, remove the hex head plug located in the timing gear end cover (as shown in *Figure 13*) by using a Hex wrench. Insert an Hex wrench into the gear clamp and slowly turn the impellers clockwise, checking for free rotation. If binding is present, do not attempt to disengage the impellers. Remove the meter from the set and clear all obstructions or piping strain prior to reinstalling the meter. Reinstall the plug and torque to 6-7 ft-lbs after verifying free impeller rotation.

**DANGER:** Slowly depressurize the meter set before working on meter.



**Figure 13 - Remove the access plug to check impeller rotation.**

- A sufficient amount of oil is shipped with each new meter to fill the meter body reservoirs in either Top or Side Inlet configuration. Slowly add oil to the meter reservoirs until the oil level comes up to the center of the oil gauge (sight glass) as shown in *Figure 14*. Refer to *Figure 15* for oil fill/drain plugs and sight glass locations. **DO NOT OVERFILL THE RESERVOIRS.**

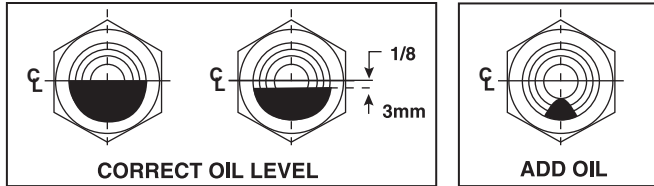
| Meter Size  | Side Inlet         | Top Inlet           |
|-------------|--------------------|---------------------|
| 8/11/15C    | 0.8 OZ. (23,7 ml)  | 3.0 OZ (88,7 ml)    |
| 2/3/5M      | 1.25 OZ. (37 ml)   | 7.6 OZ (224,8 ml)   |
| 7/11/16M    | 3.0 OZ. (88,7 ml)  | 21.85 OZ (646,2 ml) |
| 23/38/56M   | 40.2 OZ. (1,2 l)   | 154 OZ (4,55 l)     |
| 23M232 - 4" | 3.4 OZ. (100,6 ml) | 21.8 OZ. (644,7 ml) |
| 1M/3M300    | 1.25 OZ. (37 ml)   | 7.6 OZ. (224,8 ml)  |

**Table 9 - Oil Capacities**

After a meter is installed in line and oil has been added to the meter reservoirs, gas flow will rotate the meter impellers. The oil slingers will splash lubricant into the bearings. This will quickly reduce any operational friction created by dry bearings.

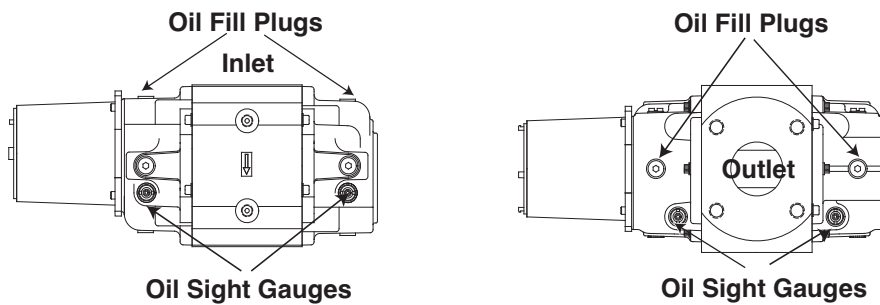


**IMPORTANT: DO NOT** add oil to the permanently lubricated Series 3 Accessory Unit. **DO NOT** drill and tap the Lexan® cover.

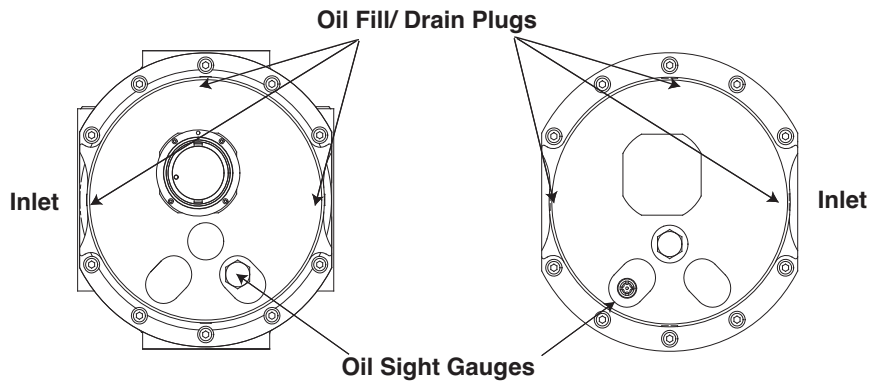


**Figure 14** - Fill oil reservoirs to mid level of sight glass.

**Series B3 8C-16M, 23M232**



**Series B3 23M-56M (Side Inlet Shown)**



**Figure 15** - Oil fill/drain plugs and oil level sight gauge locations.

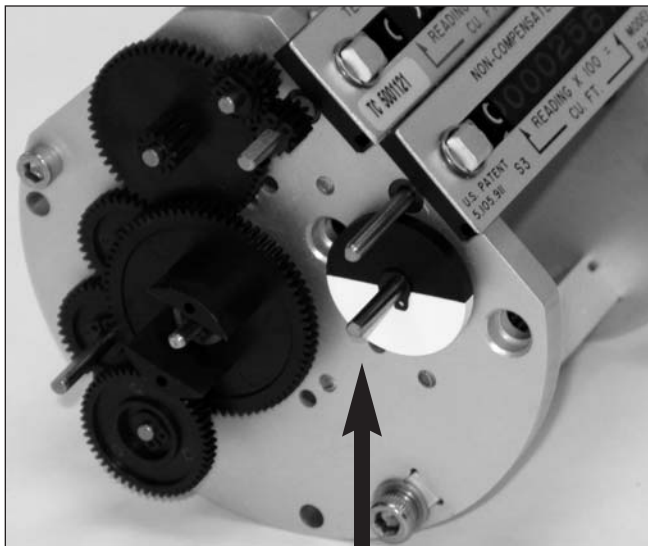
## Meter Start-Up

**IMPORTANT:** The maximum working pressure of any rotary meter is limited by casing design. Meters should not be installed where line pressure can exceed the Maximum Allowable Operating Pressure (MAOP). Refer to the basic meter body nameplate for the MAOP.

1. Slowly pressurize the meter in accordance with the following recommendations:

**IMPORTANT:** Do not exceed 5 psig/second (35 kPa/second) maximum when pressurizing. Rapid pressurization can cause an over-speed condition which may damage the meter. Resulting damage is not covered by warranty.

- a) Open the bypass and outlet (downstream of meter) gas valves.
- b) Partially open the meter inlet gas valve until the meter starts operating at low speed. Throttling the bypass valve may be necessary to initiate gas flow through the meter. Verify gas is flowing through the meter by watching for movement of the black-and white RPM wheel on the Accessory Unit. The wheel shown in *Figure 16* is visible from either the front or the side of the Lexan® cover. If movement is present, go to Step c). If the RPM dial is not turning, verify gas is being delivered to the meter. If gas is flowing to the meter inlet and the RPM wheel is not moving, go to Step e).



**Figure 16** - Movement of the RPM wheel indicates impeller rotation.

- c) Let the meter operate at low speed for several minutes. Listen closely for unusual scraping or knocking sounds.
- d) If operation is satisfactory, go directly to Step f).
- e) If unusual sounds are present or the accessory unit's RPM wheel is not turning, place the meter in bypass. Slowly depressurize and vent all pressure from the meter set before checking for piping misalignment, piping strain, torsion, or other related problems. (Release pressure at a rate less than 5 psig/second.) Once the problem is resolved, repeat the start-up procedure beginning with step a).



**DANGER: Slowly depressurize and vent all pressure from the meter set before working on meter.**

- f) Gradually open the inlet valve until a full flow is passing through the meter and the inlet valve is fully open.
- g) Slowly close the bypass valve.
- h) Follow your company's authorized procedures or common industry practices to leak test the meter and all pipe connections. Soapy water, Snoop® or gas analyzers are commonly used for this procedure.

## INSPECTION AND MAINTENANCE

### Maintenance for the Series 3 Accessory

**IMPORTANT:** NO oil is required for the Series 3 accessory unit.

The CTR, CD, ICEX, TC, TD and Solid State Pulser do not require scheduled maintenance.

To clean the Lexan® cover, use hot water and soap, mineral spirits, Isopropyl alcohol, or cleaning products approved for use on Lexan®.

**IMPORTANT:** Aromatics, Ketones, and Chlorinated hydrocarbons will damage the Lexan® cover. Do not use acetone, carbon tetrachloride, etc.



## Meter Lubrication

Use only ROOTS® Meter Oil or other instrument grade oils approved for service by the manufacturer.

Meters installed and maintained in accordance with factory recommendations can be expected to operate dependably for many years. Proper oil level and cleanliness have the greatest effect on meter's life expectancy. Visually inspect the two oil reservoirs in the meter end covers for proper mid-gauge oil levels once a month until a practical interval is determined. Add oil as necessary.

Oil change frequency will depend upon the cleanliness of the gas being measured. Change oil when the color darkens or when the level changes. Under favorable conditions, these periods may be from 3 to 5 years, or longer.



**CAUTION: THE METER END COVER IS PRESSURIZED.**  
**Bleed off the line pressure before removing the oil fill or drain plugs from the meter.**

**DO NOT add oil to the Series 3 Accessory Unit.**

## Meter Level

Since the meter is supported entirely by the gas pipe line, movement of the piping due to accidents, settling of the ground or other causes may impede meter operation and accuracy. Refer to "INSTALLATION" procedures. Make sure the meter remains level within 1/16" per foot (5 mm/m) in any direction, side-to-side and front-to-back.

## Cleaning and Flushing

**NOTE:** Before removing meter from the pipeline or performing this procedure, drain all oil from the meter end covers. Add oil after the meter has been replaced in the meter set.

After removing the meter from the line, if there is any evidence of dirt or dust in the meter, a suggested method for cleaning is to windmill the impellers (at a speed less than maximum capacity) by injecting low pressure, dry compressed air from a nozzle into the meter inlet. Flush approximately 5 ounces (150 ml) of an approved non-toxic, non-flammable solvent through the meter. Drain any residual cleaning fluid from the meter body and end covers. Use compressed air to completely dry the meter.

## ACCESSORY UNIT REMOVAL & CONVERSION PROCEDURES

The following section covers general procedures for changing complete accessory units as well as configuring the Series 3 Instrument Drive. For detailed instructions of these procedures, refer to the documentation cited at the end of each section. These general procedures require the following tools and equipment:

- 5/32" Allen wrench
- 9/64" Allen wrench
- A light grade of machine oil, grease or petroleum jelly for lubricating o-rings.
- Adjustable torque wrench with a range of 5-40 in-lbs.

### Removing the Accessory Unit from the Meter

*(Refer to Figure 17)*

Use the 5/32" Allen wrench to remove the four #10-24 screws holding the slip flange on the meter end cover. Loosen the screws in a cross or star-like pattern.

Remove the accessory unit by carefully pulling the complete assembly directly away from the meter body, taking care not to damage the male driving magnet on the accessory gear train. **IMPORTANT:** If the accessory unit is temperature compensating, slide the assembly directly away from the meter end cover until the temperature probe has cleared the end of the meter. Make sure the thermocouple (bi-metallic probe) does not bind in the probe well during the removal process. Shock and/or damage may result in a loss of compensating accuracy.

Remove the O-ring from the meter end cover, if applicable. Verify which type of o-ring seal is being used on the accessory unit before replacing.

**NOTE:** The newer Lexan® cover will have the quad-seal O-ring installed in the Lexan® Cover. If the quad o-ring comes loose from the groove in the Lexan® cover, clean the cover and O-ring with alcohol before attempting to replace the O-ring

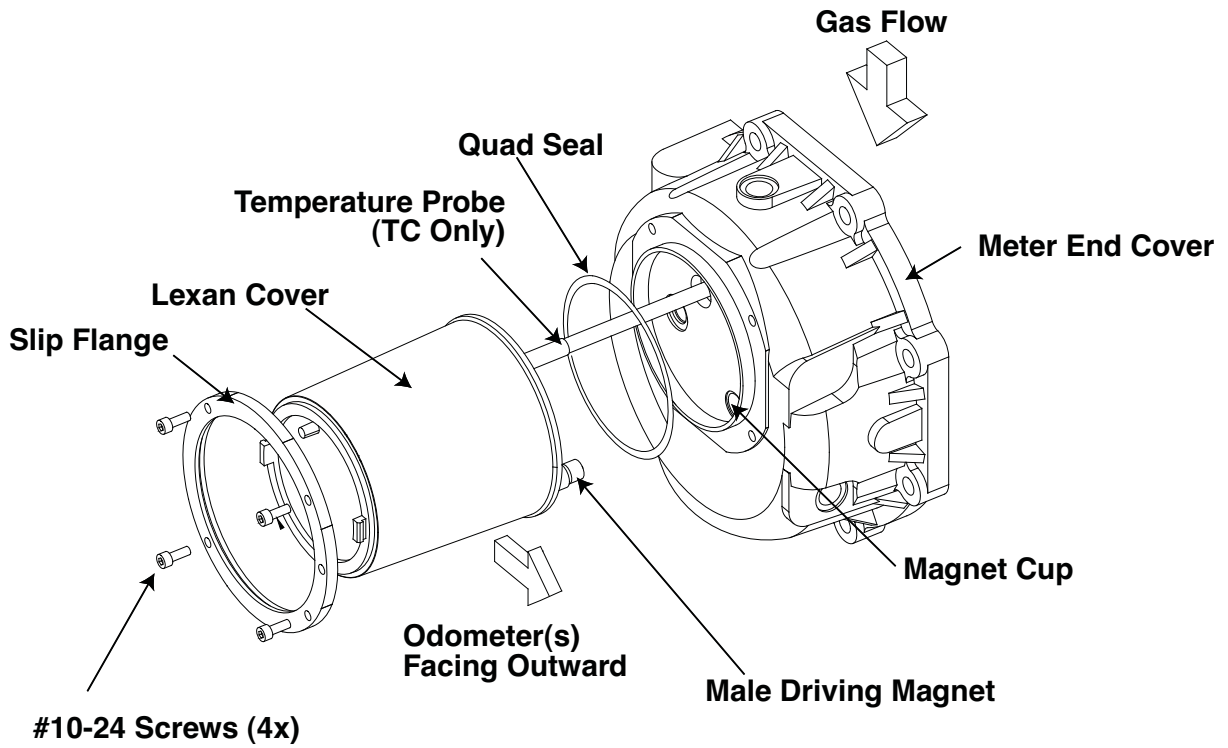
For detailed information on removing/installing the accessory unit, request document 055679-000 and 053938-000.

### Removing the Gear Reduction Assembly from the Lexan® Cover

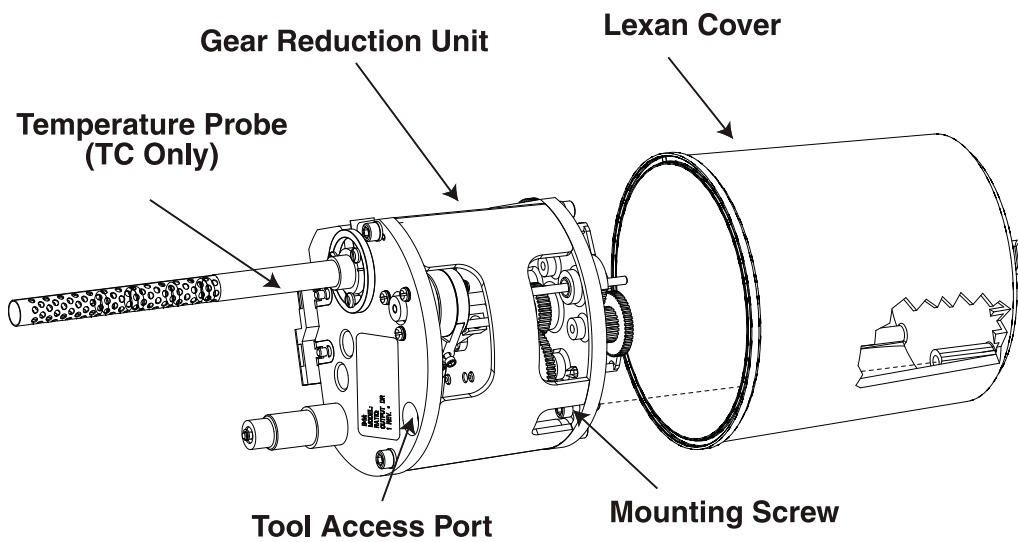
*(Refer to Figure 18)*

Use a 9/64" Allen wrench to remove the mounting screw holding the accessory unit in the Lexan® cover. The screw can be accessed through the Tool Access Port as shown in *Figure 18*.

Slide the gear reduction unit out of the Lexan® cover.



*Figure 17 - Assembling Series 3 Accessory to meter end cover.*



*Figure 18 - Exploded view of Gear Reduction Assembly and Lexan® Cover.*

## Replacing the Gear Reduction Unit in Lexan Cover (Refer to Figure 18)

1. Slide the gear reduction unit into the Lexan® cover. Align the odometer(s) with the large, clear portion of the cover. When the gear reduction unit is properly installed, the pin that is molded into the bottom of the Lexan® cover will engage a hole in the top plate of the accessory.
2. Using a 9/64" Hex wrench, insert the screw into the threaded boss on the Lexan® cover and torque to 20-25 in.-lb. Do not over tighten to avoid damage to the threaded boss.

For detailed information on Installing/Replacing the Gear Reduction Unit in Lexan® Cover, request document #055679-000.

## Installing a Complete Accessory Unit on the Meter (Refer to Figure 17)

1. Ensure the Quad Seal O-ring is fully seated into the cover.
2. Align the male driving magnet with the magnet cup in the meter body. If the Accessory Unit is temperature compensated, align the temperature probe with the probe well. Carefully slide the probe into the meter end cover probe well until the Lexan® cover meets the meter body.

**NOTE:** The foam attached to the temperature probe should not be removed. The foam is installed to prevent the ambient temperature inside the Lexan® housing from entering the probe well and affecting the temperature probe readings.

3. While holding the Accessory Unit in place, slide the slip flange over the Lexan® cover. Rotate the slip flange until all four holes in the slip flange are aligned with the four screw holes in the meter end cover. This should place the dimple in the slip flanges in alignment with the odometer(s) (non-instrument drive version only).
4. While holding the slip flange to the meter's end cover, insert the four #10-24 screws into position and tighten in a cross or star-like pattern to 6-9 ft.-lb. When properly installed, the slip flange will be in continuous contact with the meter end cover.
5. If applicable, follow your company procedures for installing security devices.

For detailed information on installing a Complete Accessory Unit on the Meter, request document #055679-000.

## Instrument Drive Conversion (Side Inlet to Top Inlet Conversion)

The following procedures are required to change the position of the instrument drive assembly and drive dog rotation direction. Refer to Figures 19, 20 and 21 for component locations.

**NOTE:** Regardless of Side Inlet or Top Inlet meter installation, the Instrument Drive Mounted device must always be installed in a vertical position during operation. Refer to the "METER INSTALLATION - Piping Configurations" section of this manual for proper meter mounting practices.

1. Use a flat blade screwdriver to remove the two 1/4-20 screws holding the Universal Instrument Adapter Plate to the ID support assembly.
2. Using the 5/32" Allen wrench, remove the four #10-24 screws holding the neck of the ID Support Assembly to the aluminum ID Housing.
3. Using a 5/32" Allen wrench, remove the two #10-24 screws holding the Side Cover Plate onto the aluminum ID housing. Remove the cover plate.
4. Install the ID support assembly in the vertical mounting position (where the cover plate was removed). Torque the screws to 37-40 in.-lb.
5. Re-install the Side Cover Plate to the position from where the ID Support was removed. Torque the screws to 5-7 in.-lb.
6. Using a 5/32" Allen wrench, remove the two #10-24 screws holding the Front Cover Plate onto the aluminum ID housing. Remove the cover plate.
7. Using a 5/32" Allen wrench, remove the two #10-24 screws holding the Bevel Gear Train Assembly in place. Make sure the O-ring behind the Bevel Gear Train Assembly remains attached to the back of the assembly. Do not allow anything to contaminate the O-ring.
8. Making sure the O-ring remains in place, re-install the Bevel Gear Train Assembly in the vertical position. Torque these screws to 5-7 in.-lb.
9. Ensure the rotation is set as desired and the Bevel Gear Train Assembly engages properly with the ID drive shaft. Windmill the meter to verify proper rotation of the Drive Dog.
10. Install the Front Cover and torque these screws to 5-7 in.-lb.

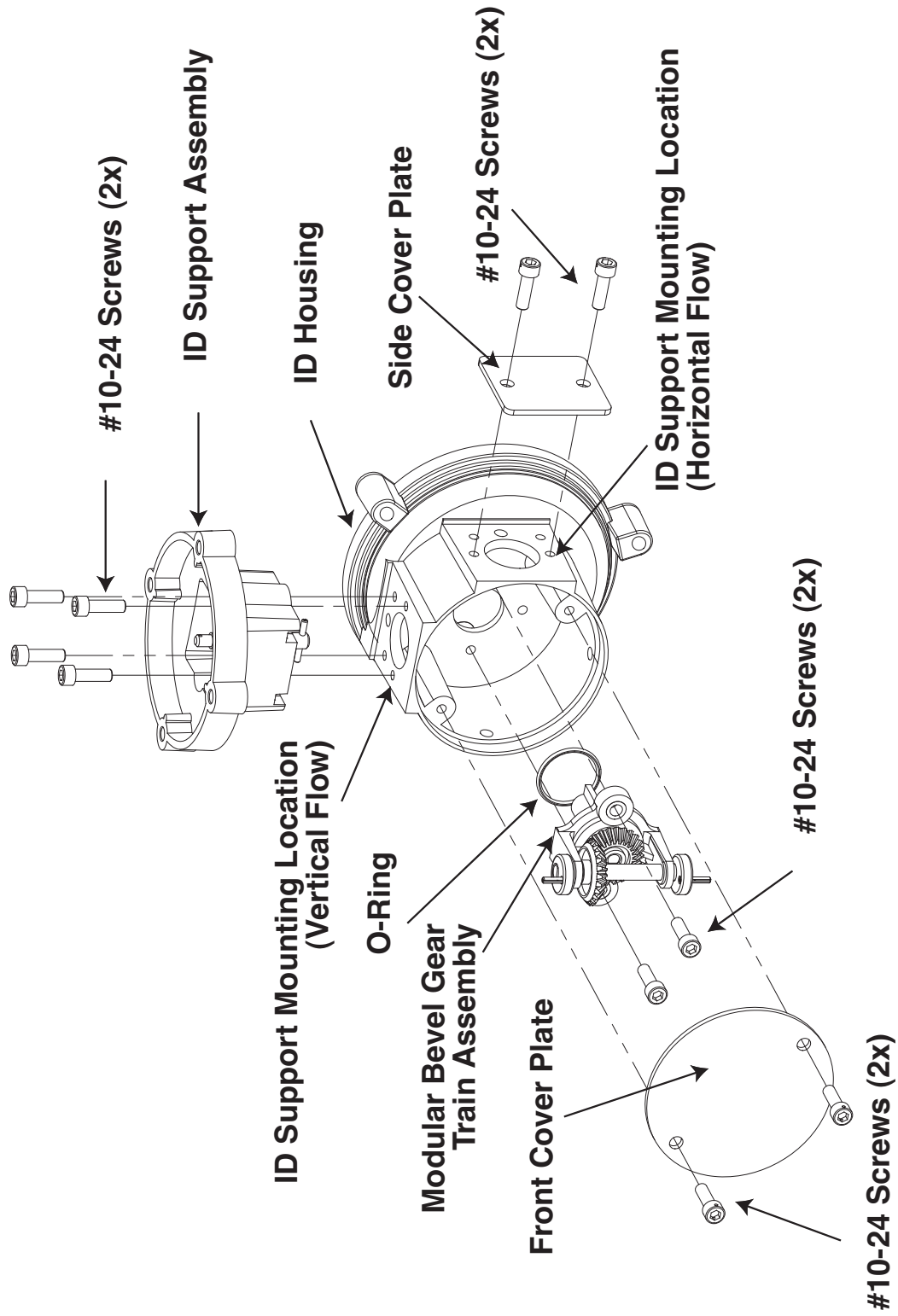
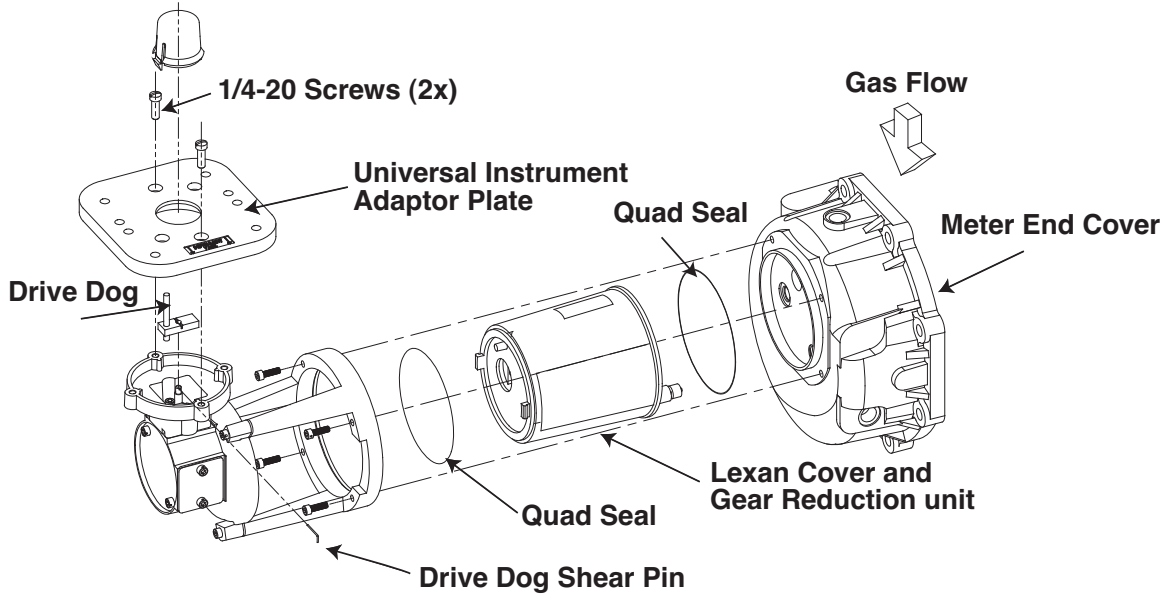
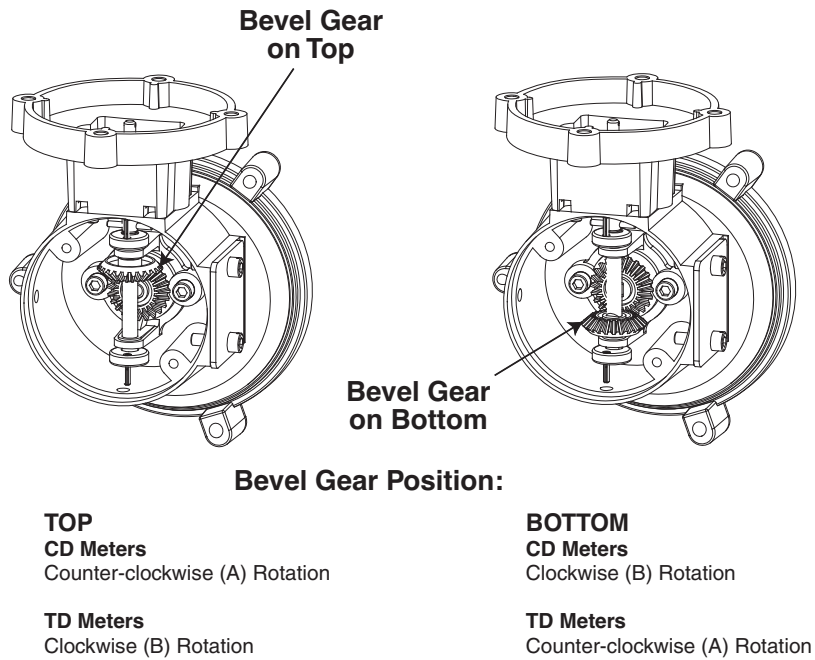


Figure 19 - Exploded View of Instrument Drive (ID) Assembly.



**Figure 20** - Assembly Instrument Drive to meter end cover.



**Figure 21** - Placement of bevel gears determines rotational direction.

11. If applicable, follow your company procedures for installing tamper-evident security devices.
12. Install the Instrument Drive Adapter Plate onto the ID Support Housing.

For detailed information on Instrument Drive Side Inlet to Top Inlet Conversion, request document B054082-091.

### Changing the Rotational Direction of the Instrument Drive

All meters with an instrument drive are shipped from the Factory with the “drive dog” rotating in a Clockwise direction (CW-B) unless otherwise specified at time of order. To change to Counter-clockwise rotation (CCW-A), use the following procedure:

1. Using a 5/32” Allen wrench, remove the two #10-24 screws that hold the Front Cover Plate onto the aluminum ID housing. Remove the cover plate. Refer to *Figure 19* for component identification.
2. Remove the two #10-24 screws holding the Modular Bevel Gear Train Assembly in place. Make sure the O-ring behind the modular assembly remains attached to the back of the modular assembly. Do not allow sand, dirt, or other debris to contaminate the O-ring.
3. Rotate the modular drive assembly 180° to obtain the proper Drive Dog rotation (refer to *Figure 21*). Making sure the O-ring behind modular assembly remains in place; re-install the modular gear assembly in the vertical position. Torque the screws to 5-7 in.-lb.
4. Ensure the rotation is set as desired and the modular gear assembly engages properly with the ID drive shaft. Windmill the meter or rotate the modular assembly to ensure proper rotation of the Drive Dog.
5. Re-install the Front Cover and torque the screws to 5-7 in.-lb.
6. If applicable, follow your company procedures for installing tamper-evident security devices.

For detailed information on Changing the Rotational Direction of the Drive Dog, request documents B054082-091.

### Installing a Solid State Pulsar on a CTR or TC Meter

1. Remove CTR or TC Accessory from the meter. To do this, remove the four screws securing the slip flange, and remove the slip flange. Gently pull the accessory housing assembly off the meter. Remove the screws and slip ring. Then, remove the CTR or TC accessory from its housing by loosening the screw inside the housing. As shown in *Figure 18*.
2. Install Magnet and associated parts that are supplied with this conversion assembly.
3. Installation of the gear train back into the housing is the reverse of removal done at Step 1 above. To re-install completed pulser assembly on meter see: INSTALLING A COMPLETE ACCESSORY UNIT ON THE METER above.

**NOTE:** For detailed information on the Installation of Solid State Pulsers, request documents 057162-000 and 054190-090.

### Installing a Counter with Electronic Transmitter (ICEX) to a CTR Accessory

1. Remove the CTR Accessory from the meter. To do this, remove the four screws securing the slip flange and remove the slip flange. Gently pull the accessory housing assembly off the meter. Remove the screws and slip flange. Then, remove the CTR accessory from its housing by loosening the screw inside the housing. See *Figure 18*.
2. Install Magnet and associated parts that are supplied with this conversion assembly.
3. Installation of the gear train back into the housing is the reverse of removal done at Step 1 above. To re-install completed pulser assembly on meter see: INSTALLING A COMPLETE ACCESSORY UNIT ON THE METER above.

**NOTE:** For detailed information on the Installation of the ICEX, request document #056098-100.

## Installing an AMR Adapter

1. The CTR or TC must be removed from the meter. To do this remove the four screws that attach the Accessory Unit to the meter. Slide the Slip Flange off the Accessory Unit.
2. Gently pull the Accessory Unit straight back away from the meter. Special care should be taken when removing a TC unit of any kind so as not to bend or damage the temperature probe.
3. Remove the CTR or TC from the housing by loosening the screw inside the Lexan Accessory Housing. Slide the CTR/TC Assembly out of the Housing. Set aside this Accessory Housing, as a new AMR Adapter Housing will replace it.
4. Place the Slip Flange over the New AMR Adapter Accessory Housing.
5. Verify that the AMR adapter plate is oriented in the correct position to ensure the AMR device is upright. AMR vent holes should always be facing the ground. Using the hex wrench, install the four #10-24 socket head cap screws to assemble the AMR Adapter plate to the AMR Adapter Accessory Housing. Tighten the four screws to 8-10 in-lb.
6. Carefully slide the CTR/TC Assembly into the Housing. **CAUTION: Make sure the output Drive Shaft of the Counter/TC unit aligns and inserts into the Coupling in the AMR Adapter Accessory Housing by ensuring the paddle on coupling aligns with slot on 72 tooth gear.**
7. Install the Slip Flange onto the meter cover, with countersunk side facing the meter. Tighten the screws in a star-like pattern and torque to 47-53 in-lb.
8. Press fit the appropriate Drive Dog onto the customer supplied AMR and install assembled AMR onto AMR adapter plate.

**NOTE:** For detailed information on the FIELD INSTALLATION of AMR adapters, request documents 057862-000 or 058779-000.

## TESTING

### General

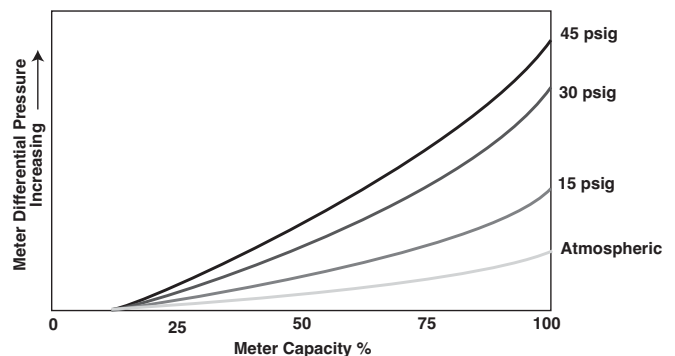
Rotary meters are tested for accuracy by several industry accepted methods. These test methods include, but are not limited to transfer, bell, piston, sonic nozzle, and critical flow proving. The Differential Test is unique to rotary meters and is a convenient method of comparing a meter's performance to previous or original performance records. Differential testing is accepted by many State Utility Commissions as a means of periodically verifying that the original accuracy of a meter has remained unchanged.

### Differential Test

Only a change in the internal resistance of a meter can affect its accuracy. Any increase in the resistance to flow will increase the pressure drop between the inlet and outlet of the meter, thus increasing the differential pressure drop. This is why the meter differential pressure appears as a prime indicator of meter condition.

Although accuracy cannot be directly determined by a differential test, it has been shown that an increase of up to 50 percent in the differential pressure, at the higher flow rates (25% and above), can be tolerated without affecting meter accuracy by more than 1 percent. Supportive technical data is available upon request.

Usually flushing a meter will eliminate a high differential caused by minor contamination. Refer to "INSPECTION AND MAINTENANCE, Cleaning and Flushing" sections for cleaning instructions.



**Figure 22** - Differential Curves change as pressure increases.

**Establishing Baseline Curves**

Developing an original differential baseline curve is recommended when the meter is first installed. Since any change in flow rate, line pressure or specific gravity will cause a change in the differential, at least three (3) test points are required at gas flow rates from 25% to 100% of meter capacity. (As shown in *Figure 22*, the resulting points will be non-linear, so a minimum of three points is necessary to establish a curve.) Plot the points on a graph and then connect the points to form a curve. This provides an accurate baseline for comparison to later tests. To help with record keeping, a data chart like the one shown in

*Figure 23* will allow the technician to compare new test data to older data.

A test under actual operating conditions will provide the most reliable data for future checks of a meter’s operating condition. This is particularly important when the line pressure is higher than 15 PSIG (200 kPa Absolute). Since meter differential pressure increases with line pressure, multiple curves may be necessary for meters under varying line pressure conditions.

| <i>Differential - Rate Test Data - SAMPLE SHEET</i> |                 |                         |                        |                        |                              |                                       |                            |             |               |
|---|-----------------|-------------------------|------------------------|------------------------|------------------------------|---------------------------------------|----------------------------|-------------|---------------|
| <b>Meter Model:</b>                                 |                 |                         |                        | <b>Mfg. Serial No:</b> |                              |                                       | <b>Utility Serial No.:</b> |             |               |
| <b>Location:</b>                                    |                 |                         |                        | <b>Date Installed:</b> |                              |                                       | <b>Register Reading:</b>   |             |               |
| <b>Line Pressure</b>                                | <b>Gas Temp</b> | <b>Specific Gravity</b> | <b>Volume Measured</b> | <b>Run Time</b>        | <b>Rate (ft<sup>3</sup>)</b> | <b>Differential Pressure In. W.C.</b> | <b>% Change</b>            | <b>Date</b> | <b>Tester</b> |
| <b>Initial Tests - New Meter</b>                    |                 |                         |                        |                        |                              |                                       |                            |             |               |
|   |                 |                         |                        |                        |                              |                                       |                            |             |               |
|   |                 |                         |                        |                        |                              |                                       |                            |             |               |
|   |                 |                         |                        |                        |                              |                                       |                            |             |               |
|   |                 |                         |                        |                        |                              |                                       |                            |             |               |
|   |                 |                         |                        |                        |                              |                                       |                            |             |               |
|   |                 |                         |                        |                        |                              |                                       |                            |             |               |
| <b>Periodic Check Tests</b>                         |                 |                         |                        |                        |                              |                                       |                            |             |               |
|   |                 |                         |                        |                        |                              |                                       |                            |             |               |
|   |                 |                         |                        |                        |                              |                                       |                            |             |               |
|   |                 |                         |                        |                        |                              |                                       |                            |             |               |
|   |                 |                         |                        |                        |                              |                                       |                            |             |               |

**Figure 23** - Having a single data chart for each meter provides a detailed history of differential rate tests for future use.



## Differential Test Procedure

Testing requires differential pressure test equipment with an indicating scale range of at least 50 inches of water column. The testing device should have bypass valving and must be pressure rated for the maximum metering line pressure for the test. Pressure lines should be connected to the 1/4" meter inlet and outlet pressure taps located on the meter body as shown in *Figure 24*. For meters with Maximum pressure ratings of 300 psig (2068 kPa) or less, Pete's Plugs® can be permanently installed in the pressure taps to facilitate testing.

A pressure gauge is used to verify pressure readings. A stop watch is used to "clock" the meter RPM for calculating gas flow rate.

Pete's Plugs® is a registered trademark of Peterson Equipment Company.

**CAUTION: When the meter is pressurized, follow applicable safety rules and use appropriate personal protective equipment.**

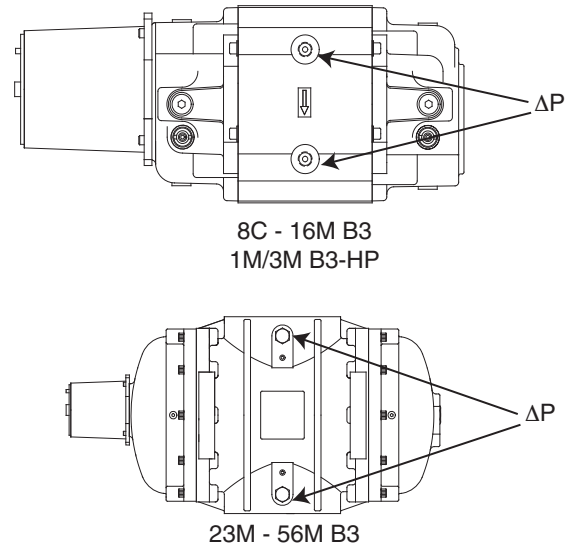
1. Install the pressure differential test equipment into the meter inlet and outlet differential taps. Follow the manufacturer's instructions for proper installation and operating procedures. On the upstream side of the meter, install a pressure gauge or other pressure standard if not already a part of the test equipment.
2. Adjust the meter bypass and the meter inlet valves until the meter is operating at a predetermined or selected flow rate in the lower capacity range or no less than 25 percent of the meter's rated capacity. Let the flow rate stabilize.
3. Time or "clock" the passage of a predetermined volume of gas registered on the instrument to determine the Flow Rate in Actual Cubic Feet per Hour (or m<sup>3</sup>/h):

$$\text{Index Rate} = \frac{(\text{Test Volume in CF}) \times (3600)}{(\text{Test Time in Seconds})}$$

Convert the calculated flow rate to a percentage of meter rated capacity:

$$\% \text{ Meter Capacity} = \left( \frac{\text{Index Rate}}{\text{Meter Base Rating}} \right) \times 100$$

**NOTE:** The base rating for a meter can be found on the nameplate located on the body of the meter. The rating is designated in both "CFH Max" and "m<sup>3</sup>/h Max".



**Figure 24** - Differential pressure taps are located above and below the meter nameplate.

4. Record the pressure differential, line pressure, and gas specific gravity. Repeat the test to obtain an accurate average reading.

**NOTE:** At the time of meter start-up in a new installation, repeat Steps 2 - 4 at a minimum of three different flow rates, each between 25% and 100% of meter capacity. An original baseline curve should be drawn using data at a constant pressure for all three tests.

5. Remove the differential test equipment and pressure standard.
6. If this is for the baseline curve, plot and save the curve for future reference. If this is a subsequent test and the pressure differential compares against the baseline curve within acceptable limits, return the meter to full service. If the pressure differential is not within acceptable limits or has increased by 50% above the values on the baseline curve, remove the meter for inspection and if needed, for service.

After developing a baseline curve, meter condition and performance can be checked periodically by running a similar differential rate test at a single selected point. If the differential pressure increases by more than 50 percent above the original value, then inspect the meter for causes for resistance. The usual causes are binding impellers, worn bearings, contaminants such as dirt or valve grease in the metering chamber, and wrong viscosity oil or excess oil. Refer to "INSPECTION AND MAINTENANCE, Cleaning and Flushing" for cleaning instructions.

For Factory repairs and/or inspection, please call your Customer Service Representative or your ROOTS® meter supplier to request a Return Material Authorization (RMA).

### Proving Operations

The accuracy of a ROOTS® meter is easily verified using standard transfer proving techniques. A Model 5 ROOTS® Prover allows for almost hands free testing and offers four different methods for starting and stopping the test. The first two methods, which utilize original equipment included with the Model 5 Provers, are performed using the Manual Start/Stop Switch or the field meter Instrument Drive Pulser.

With the manual Start/Stop switch, the operator will input the desired volume into the Model 5 program. After the flow and temperature have stabilized, the operator will use the switch to start the test. After the field meter odometer has reached the desired volume, the operator will again push the switch to stop the test.

For noncompensated meters with an Instrument Drive, the field meter Instrument Drive Pulser mounts directly to the instrument drive and provides a more accurate automated test. The desired volume is selected and the prover will automatically start the test after conditions have stabilized. The test will then stop at the desired test volume.

Optional equipment for the Model 5 prover can include the RS-Scanner. Like the Instrument Drive Pulser, the Scanner can also automate control of the test. The Scanner can be used to test both Temperature Compensated (TC) and Non-Compensated meters. This system uses a light beam to focus and trigger on the white squares of the odometer or the high speed dial at the end of the ROOTS Meter Accessory Unit. The dial will rotate from white to black (and vice versa) triggering a pulse relating to a specific volume.

**NOTE:** On Series 3 version ROOTS Meters, the high speed wheel attached to the end of the RPM drive shaft is visible either from the front or the end of the accessory and can be used for meter testing. The wheel is shown in Figure 16 in the “Meter Start-Up” section under Meter Installation.

### TC Unit Operational Check

This procedure may be used to verify the accuracy of the TC Unit independent of the meter body accuracy. The design accuracy for the TC Unit is ± 0.5% for gas temperatures between -20°F to +120°F (-29°C and +49°C).

**NOTE:** All Series B3 ROOTS TC meters are compensated to a 60° F (or 15° C) Base Temperature.

The TC Unit Operational Check is based upon Measurement Counts (actual measurement) versus Theoretical Counts, using a 25 cycle count of the compensation cycle. This is the best method for determining the accuracy of the TC unit with the meter in service. By using the 25 cycle method, all of the gears in the TC unit make a complete revolution, and thus provides a greater amount of confidence in the resulting accuracy calculation. The method for determining the theoretical counts for a 25 cycle test is outlined in the “Calculating Theoretical Counts” section.

A ROOTS® Transfer Prover can be used for a TC Unit Operational Check in the shop or when the meter is not in service. The prover is used for flow rate control and temperature indication during the test procedure. The prover may also be used to test the meter body accuracy using the non-compensated odometer or the RPM test wheel (See: “Proving Operations,” in the previous section.) Then the information derived from the TC Unit Operational Check can be combined with the meter’s non-compensated accuracy to determine the meter’s overall accuracy using this formula:

$$\frac{(\text{meter accuracy} * \text{TC accuracy})}{100} = \text{overall or combined accuracy}$$

**NOTE:** TC Calibration is not covered in this manual other than to state that during the calibration procedure the TC probe should be immersed into a tightly controlled temperature bath set at the accessory unit’s base temperature. Calibration of the TC Unit should not be performed while the accessory is installed on the meter or with the temperature probe exposed to the atmosphere (air).

### Procedure for the TC Unit Operational Check

1. Measure and record stabilized gas (or air) temperature directly at the meter inlet using a certified temperature standard.

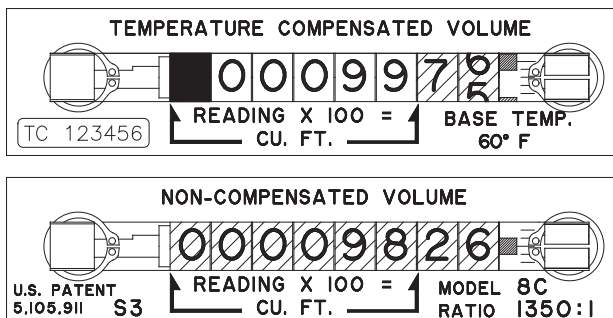
**NOTE:** Inaccurate results may occur if the gas temperature has not stabilized before starting the test.

2. Record the temperature displayed by the Accessory Unit's temperature probe. The indicated temperature is visible through the accessory housing window located above the odometers. Compare to the readings taken in Step 1. Both values should agree within  $\pm 4$  °F.

**NOTE:** The temperature indicated by the unit's temperature probe will not be used for calculation since this is an estimated reading. Use the temperature recorded in Step 1 as the reference temperature for the TC unit operational check.

3. Observe the Temperature Compensated volume odometer. When the odometer stops turning after an intermittent compensating cycle, record the last 3-digit reading and the value indicated by the graduated marks on the test wheel as the "Counts, Initial" (**Ci**) indicated on the odometer. This is read as a whole number. (Refer to the Sample Counter Reading in *Figure 25*.)

**NOTE:** Some of these digits may be partially or completely obscured by masking. The masking must be removed if the readings are not visible.



**Figure 25** - A reading of 9756 would be the number recorded for TC unit operational check.

4. After the Compensated Volume odometer has cycled 25 times and stopped, record the last 3-digit reading and the value indicated by the graduated marks on the test wheel as the "Counts, Final" (**Cf**), exactly as described in Step 3 above.

5. Use *Table 10* or the formula described in "Calculating Theoretical Counts" below to determine the "Theoretical Number of Counts" (**TNC**) for the indicated temperature recorded in Step 1.

6. Calculate the percent accuracy of the TC Unit by using the following equation:

$$\text{Percent Accuracy} = \frac{(\mathbf{Cf} - \mathbf{Ci}) \times 100}{\mathbf{TNC}}$$

**Example:** Assume the gas temperature is 53.0°F, and from *Figure 25*, the initial odometer reading (**Ci**) = 9756. We then allow the odometer to cycle 25 times and record the final reading. We will further assume the final odometer reading (**Cf**) = 2295.

**NOTE:** When **Cf** is less than **Ci**, place a "1" in front of the reading for **Cf**. In this example, the adjusted reading for **Cf** would read as "12295".

From *Table 10*, the Theoretical Number of Counts (**TNC**) = 2534.1.

Using these numbers in the "Percent Accuracy" formula, the accuracy is calculated as:

$$\frac{(12295 - 9756) \times 100}{2534.1} = 100.19\%$$

### Calculating Theoretical Counts

The number of theoretical counts (**TNC**) can be calculated for Fahrenheit as shown:

$$(\mathbf{TNC}) = \frac{(460 + \mathbf{TB}) \times (\text{Number of Cycles} \times 100)}{(460 + \mathbf{TA})}$$

Where **TB** = Base Temperature (Typically 60°F or 15C)

**TA** = Actual Gas Temperature

The number of theoretical counts (**TNC**) can be calculated for Celsius as shown:

$$(\mathbf{TNC}) = \frac{(273.15 + \mathbf{TB}) \times (\text{Number of Cycles} \times 100)}{(273.15 + \mathbf{TA})}$$

**Example:** For a 25 cycle test, the Theoretical Number of Counts (**TNC**) for gas temperature of 70.0°F and a 60° F base temperature is calculated as follows:

$$\begin{aligned} &= \frac{(460 + 60) \times (25 \times 100)}{(460 + 70.0)} \\ &= \frac{1,300,000}{530.0} = 2452.8 \end{aligned}$$

**Table 10 - Temperature Cycle Testing -Theoretical Number of Counts (TNC) for specified temperature in degrees Fahrenheit (°F). Based on 25 Temperature Compensation Cycles.**

| °F   | TNC    | °F   | TNC    | °F   | TNC    | °F   | TNC    | °F   | TNC    | °F   | TNC    |
|------|--------|------|--------|------|--------|------|--------|------|--------|------|--------|
| 50.0 | 2549.0 | 55.0 | 2524.3 | 60.0 | 2500.0 | 65.0 | 2476.2 | 70.0 | 2452.8 | 75.0 | 2429.9 |
| 50.1 | 2548.5 | 55.1 | 2523.8 | 60.1 | 2499.5 | 65.1 | 2475.7 | 70.1 | 2452.4 | 75.1 | 2429.5 |
| 50.2 | 2548.0 | 55.2 | 2523.3 | 60.2 | 2499.0 | 65.2 | 2475.2 | 70.2 | 2451.9 | 75.2 | 2429.0 |
| 50.3 | 2547.5 | 55.3 | 2522.8 | 60.3 | 2498.6 | 65.3 | 2474.8 | 70.3 | 2451.4 | 75.3 | 2428.5 |
| 50.4 | 2547.0 | 55.4 | 2522.3 | 60.4 | 2498.1 | 65.4 | 2474.3 | 70.4 | 2451.0 | 75.4 | 2428.1 |
| 50.5 | 2546.5 | 55.5 | 2521.8 | 60.5 | 2497.6 | 65.5 | 2473.8 | 70.5 | 2450.5 | 75.5 | 2427.6 |
| 50.6 | 2546.0 | 55.6 | 2521.3 | 60.6 | 2497.1 | 65.6 | 2473.4 | 70.6 | 2450.1 | 75.6 | 2427.2 |
| 50.7 | 2545.5 | 55.7 | 2520.8 | 60.7 | 2496.6 | 65.7 | 2472.9 | 70.7 | 2449.6 | 75.7 | 2426.7 |
| 50.8 | 2545.0 | 55.8 | 2520.4 | 60.8 | 2496.2 | 65.8 | 2472.4 | 70.8 | 2449.1 | 75.8 | 2426.3 |
| 50.9 | 2544.5 | 55.9 | 2519.9 | 60.9 | 2495.7 | 65.9 | 2472.0 | 70.9 | 2448.7 | 75.9 | 2425.8 |
| 51.0 | 2544.0 | 56.0 | 2519.4 | 61.0 | 2495.2 | 66.0 | 2471.5 | 71.0 | 2448.2 | 76.0 | 2425.4 |
| 51.1 | 2543.5 | 56.1 | 2518.9 | 61.1 | 2494.7 | 66.1 | 2471.0 | 71.1 | 2447.7 | 76.1 | 2424.9 |
| 51.2 | 2543.0 | 56.2 | 2518.4 | 61.2 | 2494.2 | 66.2 | 2470.5 | 71.2 | 2447.3 | 76.2 | 2424.5 |
| 51.3 | 2542.5 | 56.3 | 2517.9 | 61.3 | 2493.8 | 66.3 | 2470.1 | 71.3 | 2446.8 | 76.3 | 2424.0 |
| 51.4 | 2542.0 | 56.4 | 2517.4 | 61.4 | 2493.3 | 66.4 | 2469.6 | 71.4 | 2446.4 | 76.4 | 2423.6 |
| 51.5 | 2541.5 | 56.5 | 2516.9 | 61.5 | 2492.8 | 66.5 | 2469.1 | 71.5 | 2445.9 | 76.5 | 2423.1 |
| 51.6 | 2541.0 | 56.6 | 2516.5 | 61.6 | 2492.3 | 66.6 | 2468.7 | 71.6 | 2445.4 | 76.6 | 2422.7 |
| 51.7 | 2540.6 | 56.7 | 2516.0 | 61.7 | 2491.9 | 66.7 | 2468.2 | 71.7 | 2445.0 | 76.7 | 2422.2 |
| 51.8 | 2540.1 | 56.8 | 2515.5 | 61.8 | 2491.4 | 66.8 | 2467.7 | 71.8 | 2444.5 | 76.8 | 2421.8 |
| 51.9 | 2539.6 | 56.9 | 2515.0 | 61.9 | 2490.9 | 66.9 | 2467.3 | 71.9 | 2444.1 | 76.9 | 2421.3 |
| 52.0 | 2539.1 | 57.0 | 2514.5 | 62.0 | 2490.4 | 67.0 | 2466.8 | 72.0 | 2443.6 | 77.0 | 2420.9 |
| 52.1 | 2538.6 | 57.1 | 2514.0 | 62.1 | 2489.9 | 67.1 | 2466.3 | 72.1 | 2443.1 | 77.1 | 2420.4 |
| 52.2 | 2538.1 | 57.2 | 2513.5 | 62.2 | 2489.5 | 67.2 | 2465.9 | 72.2 | 2442.7 | 77.2 | 2420.0 |
| 52.3 | 2537.6 | 57.3 | 2513.0 | 62.3 | 2489.0 | 67.3 | 2465.4 | 72.3 | 2442.2 | 77.3 | 2419.5 |
| 52.4 | 2537.1 | 57.4 | 2512.6 | 62.4 | 2488.5 | 67.4 | 2464.9 | 72.4 | 2441.8 | 77.4 | 2419.1 |
| 52.5 | 2536.6 | 57.5 | 2512.1 | 62.5 | 2488.0 | 67.5 | 2464.5 | 72.5 | 2441.3 | 77.5 | 2418.6 |
| 52.6 | 2536.1 | 57.6 | 2511.6 | 62.6 | 2487.6 | 67.6 | 2464.0 | 72.6 | 2440.9 | 77.6 | 2418.2 |
| 52.7 | 2535.6 | 57.7 | 2511.1 | 62.7 | 2487.1 | 67.7 | 2463.5 | 72.7 | 2440.4 | 77.7 | 2417.7 |
| 52.8 | 2535.1 | 57.8 | 2510.6 | 62.8 | 2486.6 | 67.8 | 2463.1 | 72.8 | 2439.9 | 77.8 | 2417.3 |
| 52.9 | 2534.6 | 57.9 | 2510.1 | 62.9 | 2486.1 | 67.9 | 2462.6 | 72.9 | 2439.5 | 77.9 | 2416.8 |
| 53.0 | 2534.1 | 58.0 | 2509.7 | 63.0 | 2485.7 | 68.0 | 2462.1 | 73.0 | 2439.0 | 78.0 | 2416.4 |
| 53.1 | 2533.6 | 58.1 | 2509.2 | 63.1 | 2485.2 | 68.1 | 2461.7 | 73.1 | 2438.6 | 78.1 | 2415.9 |
| 53.2 | 2533.1 | 58.2 | 2508.7 | 63.2 | 2484.7 | 68.2 | 2461.2 | 73.2 | 2438.1 | 78.2 | 2415.5 |
| 53.3 | 2532.6 | 58.3 | 2508.2 | 63.3 | 2484.2 | 68.3 | 2460.7 | 73.3 | 2437.7 | 78.3 | 2415.0 |
| 53.4 | 2532.1 | 58.4 | 2507.7 | 63.4 | 2483.8 | 68.4 | 2460.3 | 73.4 | 2437.2 | 78.4 | 2414.6 |
| 53.5 | 2531.6 | 58.5 | 2507.2 | 63.5 | 2483.3 | 68.5 | 2459.8 | 73.5 | 2436.7 | 78.5 | 2414.1 |
| 53.6 | 2531.2 | 58.6 | 2506.7 | 63.6 | 2482.8 | 68.6 | 2459.3 | 73.6 | 2436.3 | 78.6 | 2413.7 |
| 53.7 | 2530.7 | 58.7 | 2506.3 | 63.7 | 2482.3 | 68.7 | 2458.9 | 73.7 | 2435.8 | 78.7 | 2413.2 |
| 53.8 | 2530.2 | 58.8 | 2505.8 | 63.8 | 2481.9 | 68.8 | 2458.4 | 73.8 | 2435.4 | 78.8 | 2412.8 |
| 53.9 | 2529.7 | 58.9 | 2505.3 | 63.9 | 2481.4 | 68.9 | 2457.9 | 73.9 | 2434.9 | 78.9 | 2412.3 |
| 54.0 | 2529.2 | 59.0 | 2504.8 | 64.0 | 2480.9 | 69.0 | 2457.5 | 74.0 | 2434.5 | 79.0 | 2411.9 |
| 54.1 | 2528.7 | 59.1 | 2504.3 | 64.1 | 2480.4 | 69.1 | 2457.0 | 74.1 | 2434.0 | 79.1 | 2411.4 |
| 54.2 | 2528.2 | 59.2 | 2503.9 | 64.2 | 2480.0 | 69.2 | 2456.5 | 74.2 | 2433.5 | 79.2 | 2411.0 |
| 54.3 | 2527.7 | 59.3 | 2503.4 | 64.3 | 2479.5 | 69.3 | 2456.1 | 74.3 | 2433.1 | 79.3 | 2410.5 |
| 54.4 | 2527.2 | 59.4 | 2502.9 | 64.4 | 2479.0 | 69.4 | 2455.6 | 74.4 | 2432.6 | 79.4 | 2410.1 |
| 54.5 | 2526.7 | 59.5 | 2502.4 | 64.5 | 2478.6 | 69.5 | 2455.1 | 74.5 | 2432.2 | 79.5 | 2409.6 |
| 54.6 | 2526.2 | 59.6 | 2501.9 | 64.6 | 2478.1 | 69.6 | 2454.7 | 74.6 | 2431.7 | 79.6 | 2409.2 |
| 54.7 | 2525.7 | 59.7 | 2501.4 | 64.7 | 2477.6 | 69.7 | 2454.2 | 74.7 | 2431.3 | 79.7 | 2408.7 |
| 54.8 | 2525.3 | 59.8 | 2501.0 | 64.8 | 2477.1 | 69.8 | 2453.8 | 74.8 | 2430.8 | 79.8 | 2408.3 |
| 54.9 | 2524.8 | 59.9 | 2500.5 | 64.9 | 2476.7 | 69.9 | 2453.3 | 74.9 | 2430.4 | 79.9 | 2407.9 |

## TROUBLE SHOOTING CHECKLIST

| Trouble                 | Item | Possible Cause  | Remedy   |
|-------------------------|------|---|--|
| No Flow Registered      | 1    | Obstruction in piping or meter.                                 | Check piping and valves to assure an open flow path. Check for impeller rotation. Refer to Step #5 in the "Placing Meter in Line" section of this manual (page 14). Check for free rotation. |
|                         | 2    | Index or RPM wheel does not turn.                               | No gas flow. Open valve or remove obstruction per Item #1.   |
| Low Volume Registration | 3    | Meter oversized for load.                                       | Use proper meter size.   |
|                         | 4    | Leak at meter bypass.   | Check bypass and valves.   |
|                         | 5    | Meter internal friction.  | See High Differential, Item #6.  |
| High Differential       | 6    | Build-up of deposits in measuring chamber.                      | Flush meter with approved solvent.   |
|                         | 7    | Worn bearings or gears.   | Replace or Return to Dresser's Product Services Department.  |
|                         | 8    | High oil level or heavy oil.                                    | Check oil level and cleanliness. Perform differential test.  |
|                         | 9    | Impellers rubbing cylinder or headplates, or meter out of time. | Rotate impellers manually to check for binding or rubbing. Refer to the section Placing meter in line. Remove obstructions and/or time the meter. Verify that the meter is level.            |
| Vibration/Noise         | 10   | Oil leaking in pipe   | Make sure the meter is properly installed<br>Refer to <i>Figure 11 &amp; 12</i>  |
|                         | 11   | Piping misalignment   | Remove piping strain. Level the meter. or strain.  |
|                         | 12   | Impellers rubbing casing.                                       | See items #7 & #9.   |
|                         | 13   | Contaminants in measuring chamber.                              | See item #6.   |

# Imperial Sizing Charts

| LINE MOUNTED                                       |        |         |         |        |        |        |       |        |        |        |        |        |        | Foot Mount |
|--|--------|---------|---------|--------|--------|--------|-------|--------|--------|--------|--------|--------|--------|------------|
| MODEL  | 8C175* | 11C175* | 15C175* | 2M175* | 3M175* | 5M175* | 7M175 | 11M175 | 16M175 | 23M175 | 23M232 | 38M175 | 56M175 | 102M125    |
| *Also available in 200 PSIG Rating                 |        |         |         |        |        |        |       |        |        |        |        |        |        |            |
| RATING PSIG  | 800    | 1100    | 1500    | 2000   | 3000   | 5000   | 7000  | 11000  | 16000  | 23000  | 23000  | 38000  | 56000  | 102000     |
| Corrected Capacity at Metering Pressure – in MSCFH |        |         |         |        |        |        |       |        |        |        |        |        |        |            |
| 1  | 0.84   | 1.15    | 1.57    | 2.09   | 3.1    | 5.2    | 7.3   | 11.5   | 16.7   | 24.0   | 24.0   | 39.7   | 58.5   | 106.6      |
| 3  | 0.95   | 1.30    | 1.77    | 2.36   | 3.5    | 5.9    | 8.3   | 13.0   | 18.9   | 27.2   | 27.2   | 44.9   | 66.2   | 120.5      |
| 5  | 1.05   | 1.45    | 1.98    | 2.63   | 4.0    | 6.6    | 9.2   | 14.5   | 21.1   | 30.3   | 30.3   | 50.0   | 73.8   | 134.3      |
| 10   | 1.33   | 1.82    | 2.48    | 3.31   | 5.0    | 8.3    | 11.6  | 18.2   | 26.5   | 38.1   | 38.1   | 62.9   | 92.8   | 168.9      |
| 15   | 1.60   | 2.20    | 2.99    | 3.99   | 6.0    | 10.0   | 14.0  | 22.0   | 31.9   | 45.9   | 45.9   | 75.8   | 111.8  | 203.6      |
| 20   | 1.87   | 2.57    | 3.50    | 4.67   | 7.0    | 11.7   | 16.3  | 25.7   | 37.4   | 53.7   | 53.7   | 88.7   | 130.8  | 238.2      |
| 25   | 2.14   | 2.94    | 4.01    | 5.35   | 8.0    | 13.4   | 18.7  | 29.4   | 42.8   | 61.5   | 61.5   | 101.6  | 149.8  | 272.9      |
| 30   | 2.41   | 3.32    | 4.52    | 6.03   | 9.0    | 15.1   | 21.1  | 33.2   | 48.2   | 69.3   | 69.3   | 114.5  | 168.8  | 307.4      |
| 40   | 2.95   | 4.06    | 5.54    | 7.39   | 11.1   | 18.5   | 25.9  | 40.6   | 59.1   | 84.9   | 84.9   | 140.3  | 206.8  | 376.7      |
| 50   | 3.50   | 4.81    | 6.56    | 8.74   | 13.1   | 21.9   | 30.6  | 48.1   | 70.0   | 100.6  | 100.6  | 166.1  | 244.8  | 445.9      |
| 60   | 4.04   | 5.56    | 7.58    | 10.10  | 15.2   | 25.3   | 35.4  | 55.6   | 80.8   | 116.2  | 116.2  | 191.9  | 282.9  | 515.2      |
| 70   | 4.58   | 6.30    | 8.59    | 11.46  | 17.2   | 28.6   | 40.1  | 63.0   | 91.7   | 131.8  | 131.8  | 217.7  | 320.9  | 584.5      |
| 80   | 5.13   | 7.05    | 9.61    | 12.82  | 19.2   | 32.0   | 44.9  | 70.5   | 102.5  | 147.4  | 147.4  | 243.5  | 358.9  | 653.7      |
| 90   | 5.67   | 7.80    | 10.63   | 14.18  | 21.3   | 35.4   | 49.6  | 78.0   | 113.4  | 163.0  | 163.0  | 269.3  | 396.9  | 723.0      |
| 100  | 6.21   | 8.54    | 11.65   | 15.53  | 23.3   | 38.8   | 54.4  | 85.4   | 124.3  | 178.6  | 178.6  | 295.1  | 434.9  | 792.1      |
| 110  | 6.76   | 9.29    | 12.67   | 16.89  | 25.3   | 42.2   | 59.1  | 92.9   | 135.1  | 194.2  | 194.2  | 320.9  | 472.9  | 861.4      |
| 120  | 7.30   | 10.04   | 13.69   | 18.25  | 27.4   | 45.6   | 63.9  | 100.4  | 146.0  | 209.9  | 209.9  | 346.7  | 511.0  | 930.6      |
| 125  | 7.57   | 10.41   | 14.20   | 18.93  | 28.4   | 47.3   | 66.2  | 104.1  | 151.4  | 217.7  | 217.7  | 359.6  | 530.0  | 965.3      |
| 135  | 8.11   | 11.16   | 15.21   | 20.29  | 30.4   | 50.7   | 71.0  | 111.6  | 162.3  | 233.3  | 233.3  | 385.4  | 568.0  |            |
| 150  | 8.93   | 12.28   | 16.74   | 22.32  | 33.5   | 55.8   | 78.1  | 122.8  | 178.6  | 256.7  | 256.7  | 424.1  | 625.0  |            |
| 175  | 10.29  | 14.14   | 19.29   | 25.72  | 38.6   | 64.3   | 90.0  | 141.4  | 205.7  | 295.7  | 295.7  | 488.6  | 720.1  |            |
| 200  | 11.64  | 16.01   | 21.83   | 29.11  | 43.7   | 72.8   |       |        |        |        |        | 334.8  |        |            |
| 232  |        |         |         |        |        |        |       |        |        |        |        | 384.7  |        |            |

| HIGH PRESSURE METERS |  |       |
|----------------------|--|-------|
| MODEL                | 1M300  | 3M300 |
| RATING               | 1000   | 3000  |
| PSIG                 | Corrected Capacity at Metering Pressure — in MSCFH |       |
| 125                  | 9.5  | 28.4  |
| 150                  | 11.2   | 33.5  |
| 175                  | 12.9   | 38.6  |
| 200                  | 14.6   | 43.7  |
| 250                  | 18.0   | 53.9  |
| 300                  | 21.3   | 64.0  |

NOTE: All capacities listed are Standard Cubic Feet per Hour (SCFH) and based upon Average Atmospheric Pressure (14.4 PSIA), Base Pressure (14.73 PSIA), and Base Temperature (60°F). Tables do not take into account Supercompressibility. Please refer to RM-135 for further information on the Application of Temperature and/or Pressure Correction Factors in Gas Measurement.

### SIZING INSTRUCTIONS

To select the proper meter size, use the Minimum Operating Pressure and the Maximum Instantaneous Hourly Flow Rate. Do not exceed meter's maximum allowable operating pressure.

To prevent oversizing of a meter, sizing should be based upon the total connected load giving consideration to the load diversity. When using this method to size a meter, a selected diversity factor times the total connected load will be used as the Maximum Instantaneous Flow Rate for sizing purposes.

A diversity factor of 0.85 is commonly used for a single application where two or more major appliances are in use (i.e. boilers, furnaces, space heaters, etc.).

As the number of appliances considered when determining a connected load increases, the diversity factor will typically decrease. For applications such as multiple ranges and water heaters, some examples of commonly used diversity factors are:

| Qty | Factor | Qty | Factor* |
|-----|--------|-----|---------|
| 0-5 | 1      | 6   | 0.9     |
| 7   | 0.85   | 8   | 0.83    |

\* The diversity factors listed above are estimates. For proper sizing, consult your company or industry standards for determining accepted values.

| ENERGY VALUE |             |
|--------------|-------------|
| Gas          | BTU/Cu. Ft. |
| Acetylene    | 1498        |
| Butane       | 3200        |
| Ethane       | 1758        |
| Ethylene     | 1606        |
| Methane      | 997         |
| Natural      | 965/1055    |
| Propane      | 2550        |

## Metric Sizing Charts

| LINE MOUNTED - METRIC              |        |      |   |       |        |       |        |        |        |        |        |        |         |         | Foot Mount |         |        |  |        |  |        |  |        |  |         |  |
|------------------------------------|--------|------|---|-------|--------|-------|--------|--------|--------|--------|--------|--------|---------|---------|------------|---------|--------|--|--------|--|--------|--|--------|--|---------|--|
| MODEL                              | 8C175* |      | 11C175*15C175*  |       | 2M175* |       | 3M175* |        | 5M175* |        | 7M175  |        | 11M175  |         | 16M175     |         | 23M232 |  | 23M175 |  | 38M175 |  | 56M175 |  | 102M125 |  |
| *Also available in 200 PSIG Rating |        |      |   |       |        |       |        |        |        |        |        |        |         |         |            |         |        |  |        |  |        |  |        |  |         |  |
| RATING                             |        |      | 22,7  | 31,2  | 42,5   | 56,6  | 85     | 141,6  | 198,2  | 311,5  | 453,1  | 651,3  | 651,3   | 1076    | 1585,7     | 2888,3  |        |  |        |  |        |  |        |  |         |  |
| PSIG                               | kPa    | BAR  | Corrected Capacity at Metering Pressure – in Nm <sup>3</sup> /H |       |        |       |        |        |        |        |        |        |         |         |            |         |        |  |        |  |        |  |        |  |         |  |
| 1                                  | 6,9    | 0,1  | 23,7  | 32,6  | 44,4   | 59,2  | 88,8   | 148,0  | 207,2  | 325,7  | 473,7  | 680,9  | 680,9   | 1125,0  | 1657,9     | 3019,7  |        |  |        |  |        |  |        |  |         |  |
| 3                                  | 20,7   | 0,2  | 26,8  | 36,8  | 50,2   | 66,9  | 100,3  | 167,2  | 234,1  | 368,0  | 535,2  | 769,3  | 769,3   | 1271,1  | 1873,2     | 3411,9  |        |  |        |  |        |  |        |  |         |  |
| 5                                  | 34,5   | 0,3  | 29,8  | 41,0  | 55,9   | 74,6  | 111,9  | 186,5  | 261,1  | 410,2  | 596,7  | 857,8  | 857,8   | 1417,2  | 2088,5     | 3804,0  |        |  |        |  |        |  |        |  |         |  |
| 10                                 | 68,9   | 0,7  | 37,5  | 51,6  | 70,4   | 93,8  | 140,7  | 234,5  | 328,3  | 516,0  | 750,5  | 1078,9 | 1078,9  | 1782,4  | 2626,8     | 4784,5  |        |  |        |  |        |  |        |  |         |  |
| 15                                 | 103,4  | 1,0  | 45,2  | 62,2  | 84,8   | 113,0 | 169,6  | 282,6  | 395,6  | 621,7  | 904,3  | 1299,9 | 1299,9  | 2147,7  | 3165,0     | 5764,9  |        |  |        |  |        |  |        |  |         |  |
| 20                                 | 137,9  | 1,4  | 52,9  | 72,7  | 99,2   | 132,3 | 198,4  | 330,6  | 462,9  | 727,4  | 1058,1 | 1521,0 | 1521,0  | 2513,0  | 3703,3     | 6745,3  |        |  |        |  |        |  |        |  |         |  |
| 30                                 | 206,8  | 2,1  | 68,3  | 93,9  | 128,0  | 170,7 | 256,1  | 426,8  | 597,5  | 938,9  | 1365,7 | 1963,2 | 1963,2  | 3243,5  | 4779,8     | 8706,1  |        |  |        |  |        |  |        |  |         |  |
| 40                                 | 275,8  | 2,8  | 83,6  | 115,0 | 156,8  | 209,1 | 313,7  | 522,9  | 732,1  | 1150,4 | 1673,3 | 2405,3 | 2405,3  | 3974,0  | 5856,4     | 10667,0 |        |  |        |  |        |  |        |  |         |  |
| 50                                 | 344,7  | 3,4  | 99,0  | 136,2 | 185,7  | 247,6 | 371,4  | 619,0  | 866,6  | 1361,8 | 1980,8 | 2847,5 | 2847,5  | 4704,5  | 6932,9     | 12627,8 |        |  |        |  |        |  |        |  |         |  |
| 60                                 | 413,7  | 4,1  | 114,4   | 157,3 | 214,5  | 286,0 | 429,1  | 715,1  | 1001,2 | 1573,3 | 2288,4 | 3289,6 | 3289,6  | 5435,0  | 8009,4     | 14588,7 |        |  |        |  |        |  |        |  |         |  |
| 70                                 | 482,6  | 4,8  | 129,8   | 178,5 | 243,3  | 324,5 | 486,7  | 811,2  | 1135,8 | 1784,8 | 2596,0 | 3731,8 | 3731,8  | 6165,5  | 9086,0     | 16549,5 |        |  |        |  |        |  |        |  |         |  |
| 80                                 | 551,6  | 5,5  | 145,2   | 199,6 | 272,2  | 362,9 | 544,4  | 907,3  | 1270,3 | 1996,2 | 2903,6 | 4173,9 | 4173,9  | 6896,0  | 10162,5    | 18510,3 |        |  |        |  |        |  |        |  |         |  |
| 90                                 | 620,5  | 6,2  | 160,5   | 220,8 | 301,0  | 401,4 | 602,1  | 1003,5 | 1404,9 | 2207,7 | 3211,2 | 4616,1 | 4616,1  | 7626,5  | 11239,1    | 20471,2 |        |  |        |  |        |  |        |  |         |  |
| 100                                | 689,5  | 6,9  | 175,9   | 241,9 | 329,8  | 439,8 | 659,8  | 1099,6 | 1539,5 | 2419,2 | 3518,8 | 5058,2 | 5058,2  | 8357,0  | 12315,6    | 22432,0 |        |  |        |  |        |  |        |  |         |  |
| 125                                | 861,8  | 8,6  | 214,4   | 294,8 | 401,9  | 535,9 | 803,9  | 1339,9 | 1875,9 | 2947,8 | 4287,7 | 6163,6 | 6163,6  | 10183,3 | 15006,9    | 27334,1 |        |  |        |  |        |  |        |  |         |  |
| 150                                | 1034,2 | 10,3 | 252,8   | 347,7 | 474,0  | 632,0 | 948,1  | 1580,2 | 2212,3 | 3476,5 | 5056,7 | 7269,0 | 7269,0  | 12009,6 | 17698,3    |         |        |  |        |  |        |  |        |  |         |  |
| 175                                | 1206,6 | 12,1 | 291,2   | 400,5 | 546,1  | 728,2 | 1092,3 | 1820,5 | 2548,7 | 4005,2 | 5825,6 | 8374,4 | 8374,4  | 13835,8 | 20389,6    |         |        |  |        |  |        |  |        |  |         |  |
| 200                                | 1379,0 | 13,8 | 329,7   | 453,4 | 618,2  | 824,3 | 1236,5 | 2060,7 |        |        |        |        |         |         |            |         |        |  | 9479,7 |  |        |  |        |  |         |  |
| 232                                | 1599,6 | 16,0 |   |       |        |       |        |        |        |        |        |        | 10894,6 |         |            |         |        |  |        |  |        |  |        |  |         |  |

| HIGH PRESSURE METERS - METRIC |        |      |   |        |
|-------------------------------|--------|------|---|--------|
| MODEL                         | 1M300  |      | 3M300                                     |        |
| RATING                        | 28,3   |      | 85,0                                      |        |
| PSIG                          | Bar    | kPa  | Corrected Capacity at                     |        |
|                               |        |      | Metering Pressure - in Nm <sup>3</sup> /H |        |
| 125                           | 861,8  | 8,6  | 268,0                                     | 803,9  |
| 150                           | 1034,2 | 10,3 | 316,1                                     | 948,1  |
| 175                           | 1206,6 | 12,1 | 364,1                                     | 1092,3 |
| 200                           | 1379,0 | 13,8 | 412,2                                     | 1236,5 |
| 250                           | 1723,7 | 17,2 | 508,3                                     | 1524,8 |
| 300                           | 2068,4 | 20,7 | 604,5                                     | 1813,2 |

# POWER EQUIPMENT COMPANY

2011 WILLIAMSBURG ROAD  
RICHMOND, VIRGINIA 23231  
(804) 236-3800 (FAX) (804) 236-3882  
[www.peconet.com](http://www.peconet.com)

