



SERIES B3-HPC: 1M1480 ROOTS® Meter

	UNITS	Imperial	UNITS	Metric
Temperature Range	deg. F	-40 to +140	deg. C	-40 to +60
Base Rating (Q Max.)	acfh	1000	m ³ /h	28,3
Max. Operating Pressure (MAOP)	psig	1480	kPa	10200
Leak Test (125% MAOP)	psig	1850	kPa	12750
Static Test (2 x MAOP)	psig	2960	kPa	20400
Rangeability +/- 1%	ratio	18:1	ratio	18:1
Rangeability +/- 2%	ratio	33:1	ratio	33:1
Start Rate	cfh	2.5	m ³ /h	0,0708
Stop Rate	cfh	2	m ³ /h	0,0566
Flow Rate @ 0.5" w.c., Gas	cfh	1000+	m ³ /h	28,3+
Avg. Differential, 100% Flow	in. w.c.	0.4	mbar	0.7
Max. Pressurization Rate	psig/sec	5	kPa/sec	35
Max. Operating Speed	rpm	1125	rpm	1125
Gear Ratio	ratio	675:1	ratio	238,2352:1
Displaced Volume/Revolution	cf	0.014815	m ³	0,000420
Drive Rate, CD	cf/rev	10	m ³ /rev	0,1
Min. Odometer Reading	cf	0.2	m ³	0,002
Odometer Turnover	yrs.	10.5	yrs.	4,03
Nominal Pipe Size	in.	2	mm	50,8
Flange-to-Flange	in.	10-3/4	mm	273
Flange Connection	ANSI	600#RF	ANSI	600#RF
Bolts per Flange	qty.	8	qty.	8
Bolt Size ¹	in.	5/8 - 11	in.	5/8 - 11
Flange Bolt Hole Depth	in.	1-1/8	mm	28,6
Bolt Torque: Lubricated/Non-Lub.	ft.-lb.	80	N-m	108
Restricting Orifice (100%)	in.	0.265	mm	6,747
Oil Capacity - Side Inlet	oz.	4.2	ml	124
Oil Capacity - Top Inlet	oz.	11	ml	325
<i>Counter Version (CTR)²</i>				
Net Weight	lbs.	107	kg	48,5
Shipping Weight	lbs.	132	kg	59,9
Carton Size	in.	26 x 15 x 16	cm	66 x 38 x 40
<i>Counter with Instrument Drive (CD)²</i>				
Net Weight	lbs.	110	kg	49,9
Shipping Weight	lbs.	135	kg	61,2
Carton Size	in.	26 x 15 x 16	cm	66 x 38 x 40

NOTES:

¹ Bolt Length varies by application.

² Weights and dimensions available for CPS upon request.

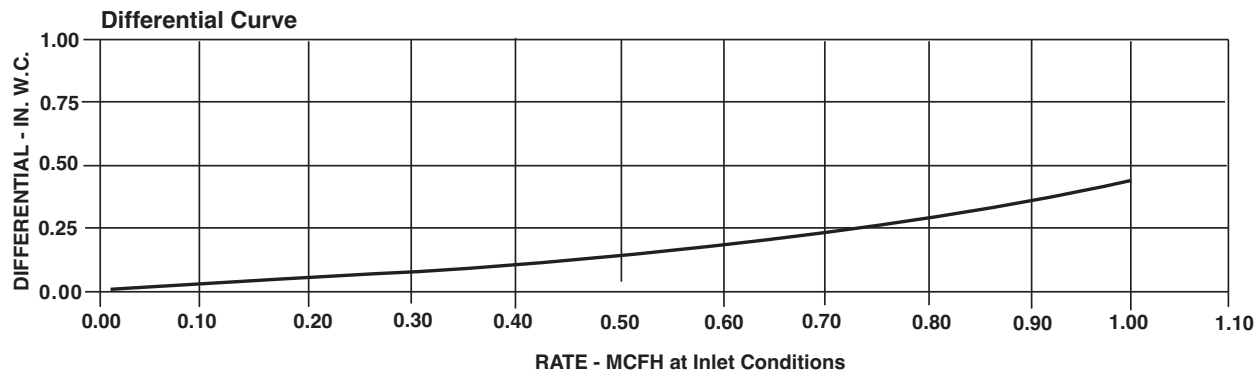
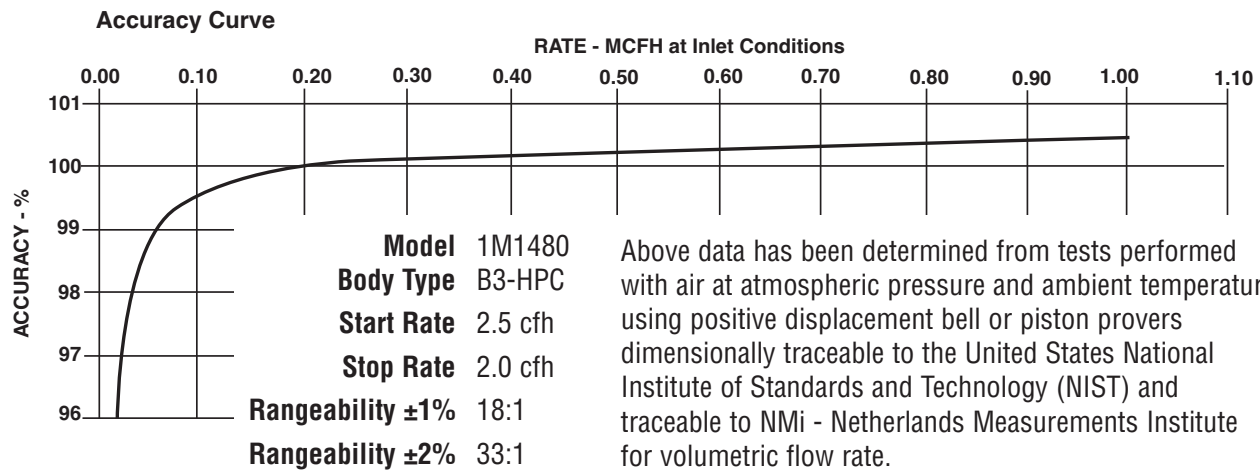

1M1480 Series B3-HPC	Overall Length		Overall Height		Width (Flange/Flange)		Centerline to Accessory End (CL-AU)		Request Detailed Drawing Number
	inches	mm	inches	mm	inches	mm	inches	mm	
CTR	16-1/32	407	8-5/8	218	10-3/4	273	10-1/4	260	D054757-000
CD	19-27/32	504	8-5/8	218	10-3/4	273	14-1/16	358	D054434-000
CPS	18-7/32	462	8-5/8	218	10-3/4	273	12-7/16	316	D054758-000

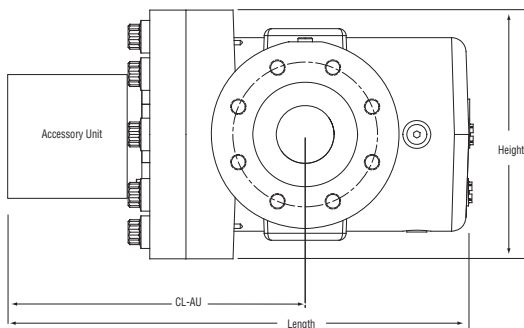

To order

Specify: Meter Series, Size and Type (i.e., ROOTS Meter Series B3-HPC 1M1480 CTR).

For CD, specify Inlet (Top or Side) and ID Rotation (CW-B or CCW-A).

For Pulser, specify Single or Dual Connectors and Connector Type (MS Circular, Conduit, or Cable Gland).

For more specific ordering information on the electronic products, request: TS:SSP or TS: MC.

Contact the factory for other available information, options, or special requests.

POWER EQUIPMENT COMPANY

2011 WILLIAMSBURG ROAD
 RICHMOND, VIRGINIA 23231
 (804) 236-3800 (FAX) (804) 236-3882
 www.peconet.com



www.dresser.com