

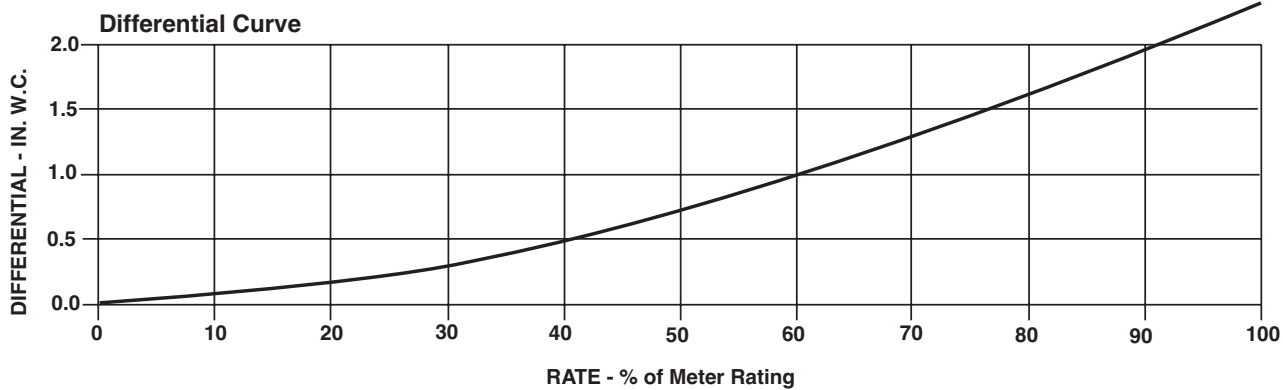

## SERIES B3: 56M175 ROOTS® Meter

	<b>UNITS</b>	<b>Imperial</b>	<b>UNITS</b>	<b>Metric</b>
Temperature Range	deg. F	-40 to +140	deg. C	-40 to +60
Base Rating (Q Max.)	acfh	56000	m <sup>3</sup> /h	1575
Max. Operating Pressure (MAOP)	psig	175	kPa	1200
Leak Test (125% MAOP)	psig	219	kPa	1510
Static Test (2 x MAOP)	psig	350	kPa	2400
Rangeability +/- 1%	ratio	53:1	ratio	53:1
Rangeability +/- 2%	ratio	109:1	ratio	109:1
Start Rate	cfh	40	m <sup>3</sup> /h	1,1327
Stop Rate	cfh	29	m <sup>3</sup> /h	0,8212
Flow Rate @ 0.5" w.c., Gas	cfh	23000	m <sup>3</sup> /h	651,3
Avg. Differential, 100% Flow	in. w.c.	2.2	mbar	5,5
Max. Pressurization Rate	psig/sec	5	kPa/sec	35
Max. Operating Speed	rpm	1344	rpm	1344
Gear Ratio	ratio	144:1	ratio	508,3120:1
Displaced Volume/Revolution	cf	0.69444	m <sup>3</sup>	0,019664
Drive Rate, CD	cf/rev	100	m <sup>3</sup> /rev	10
Min. Odometer Reading	cf	2.0	m <sup>3</sup>	0,02
Odometer Turnover	yrs.	2.0	yrs.	7,3
Nominal Pipe Size	in.	8	mm	200
Flange-to-Flange	in.	21	mm	533,4
Flange Connection	ANSI	150#FF	ANSI	150#FF
Bolts per Flange	qty.	8	qty.	8
Bolt Size <sup>1</sup>	in.	3/4 - 10	in.	3/4 - 10
Flange Bolt Hole Depth	in.	1-5/8	mm	41,2
Bolt Torque: Lubricated/Non-Lub.	ft.-lb.	80	N-m	108
Restricting Orifice (120%)	in.	2-1/4	mm	57,150
Oil Capacity - Side Inlet	oz.	40.2	ml	1189
Oil Capacity - Top Inlet	oz.	154	ml	4554
Counter Version (CTR) <sup>2</sup>				
Net Weight	lbs.	284	kg	128,8
Shipping Weight	lbs.	314	kg	142,4
Carton Size	in.	54 x 24 x 32	cm	137 x 61 x 81
Counter with Instrument Drive (CD) <sup>2</sup>				
Net Weight	lbs.	287	kg	130,2
Shipping Weight	lbs.	317	kg	143,8
Carton Size	in.	54 x 24 x 32	cm	137 x 61 x 81

**NOTES:**<sup>1</sup> Bolt Length varies by application.<sup>2</sup> Weights and dimensions available for CPS upon request.

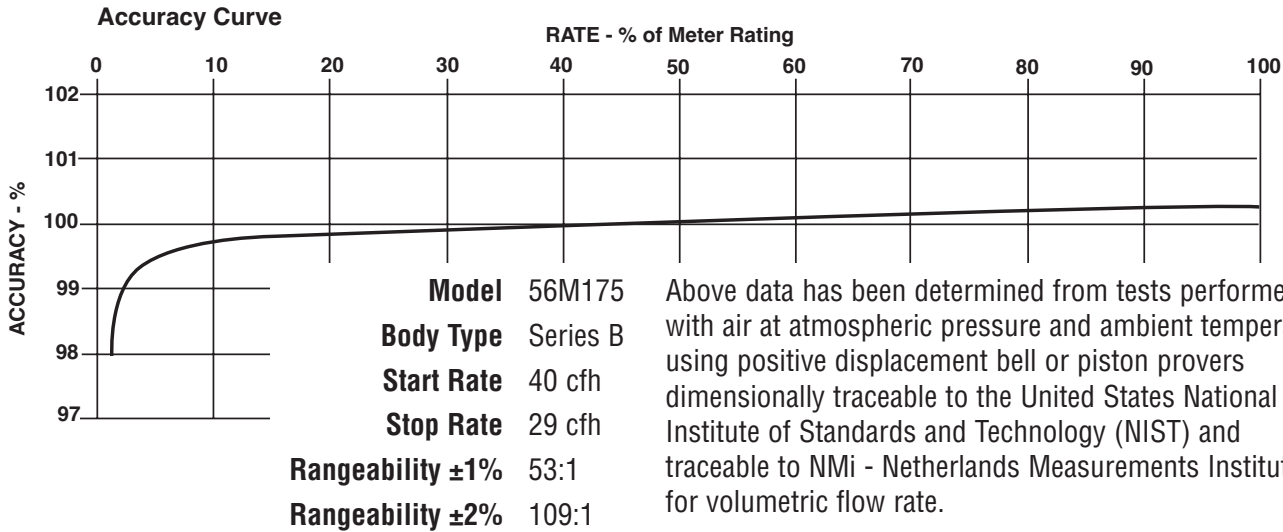

56M175 Series B3	Overall Length		Overall Height		Width (Flange/Flange)		Centerline to Accessory End (CL-AU)		Request Detailed Drawing Number
	inches	mm	inches	mm	inches	mm	inches	mm	
CTR	38-1/32	966	18	457	21	533	21-11/32	418	D054750-001
CD	42-1/2	1080	18	457	21	533	25-17/32	649	D054433-001
ICPW/ITPW/ICEX	39-19/32	1006	18	457	21	533	23-1/16	586	D057701-000
IMC/W2	42-13/32	1007	18	457	21	533	25-23/32	653	D057732-000

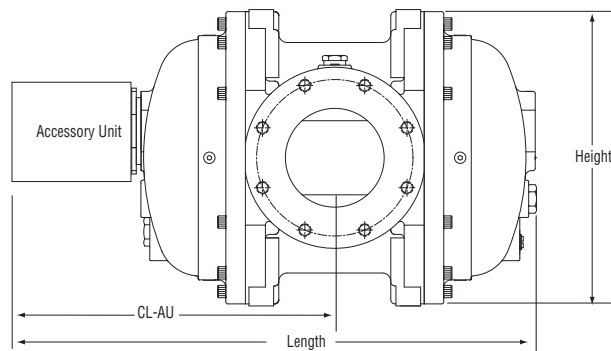

**To order**

Specify: Meter Series, Size and Type (i.e., ROOTS Meter Series B3 56M175 CD).

For CD, specify Inlet (Top or Side) and ID Rotation (CW-B or CCW-A).

For Pulsar, specify Single or Dual Connectors and Connector Type (MS Circular, Conduit or Cable Gland).

For more specific ordering information on the electronic products, request: TS:SSP or TS: IMCW2.

Contact the factory for other available information, options, or special requests.

**POWER EQUIPMENT COMPANY**  
 2011 WILLIAMSBURG ROAD  
 RICHMOND, VIRGINIA 23231  
 (804) 236-3800 (FAX) (804) 236-3882

