



SERIES B3: 38M175 ROOTS® Meter

	UNITS	Imperial	UNITS	Metric
Temperature Range	deg. F	-40 to +140	deg. C	-40 to +60
Base Rating (Q Max.)	acfh	38000	m ³ /h	1050
Max. Operating Pressure (MAOP)	psig	175	kPa	1200
Leak Test (125% MAOP)	psig	219	kPa	1510
Static Test (2 x MAOP)	psig	350	kPa	2400
Rangeability +/- 1%	ratio	90:1	ratio	90:1
Rangeability +/- 2%	ratio	110:1	ratio	110:1
Start Rate	cfh	27	m ³ /h	0,7646
Stop Rate	cfh	20	m ³ /h	0,5663
Flow Rate @ 0.5" w.c., Gas	cfh	20600	m ³ /h	583,3
Avg. Differential, 100% Flow	in. w.c.	1.9	mbar	4,7
Max. Pressurization Rate	psig/sec	5	kPa/sec	35
Max. Operating Speed	rpm	1140	rpm	1140
Gear Ratio	ratio	180:1	ratio	63,5771:1
Displaced Volume/Revolution	cf	0.555556	m ³	0,015723
Drive Rate, CD	cf/rev	100	m ³ /rev	1
Min. Odometer Reading	cf	2.0	m ³	0,02
Odometer Turnover	yrs.	3.0	yrs.	1,1
Nominal Pipe Size	in.	6	mm	150
Flange-to-Flange	in.	18	mm	457,2
Flange Connection	ANSI	150#FF	ANSI	150#FF
Bolts per Flange	qty.	8	qty.	8
Bolt Size ¹	in.	3/4 - 10	in.	3/4 - 10
Flange Bolt Hole Depth	in.	1-5/8	mm	41,2
Bolt Torque: Lubricated/Non-Lub.	ft.-lb.	80	N-m	108
Restricting Orifice (120%)	in.	1-29/32	mm	48,419
Oil Capacity - Side Inlet	oz.	40.2	ml	1189
Oil Capacity - Top Inlet	oz.	154	ml	4554
Counter Version (CTR) ²				
Net Weight	lbs.	244	kg	110,7
Shipping Weight	lbs.	274	kg	124,3
Carton Size	in.	44 x 24 x 21-3/4	cm	111 x 61 x 55
Counter with Instrument Drive (CD) ²				
Net Weight	lbs.	247	kg	112,0
Shipping Weight	lbs.	277	kg	125,7
Carton Size	in.	44 x 24 x 21-3/4	cm	111 x 61 x 55

NOTES:

¹ Bolt Length varies by application.
² Weights and dimensions available for CPS upon request.

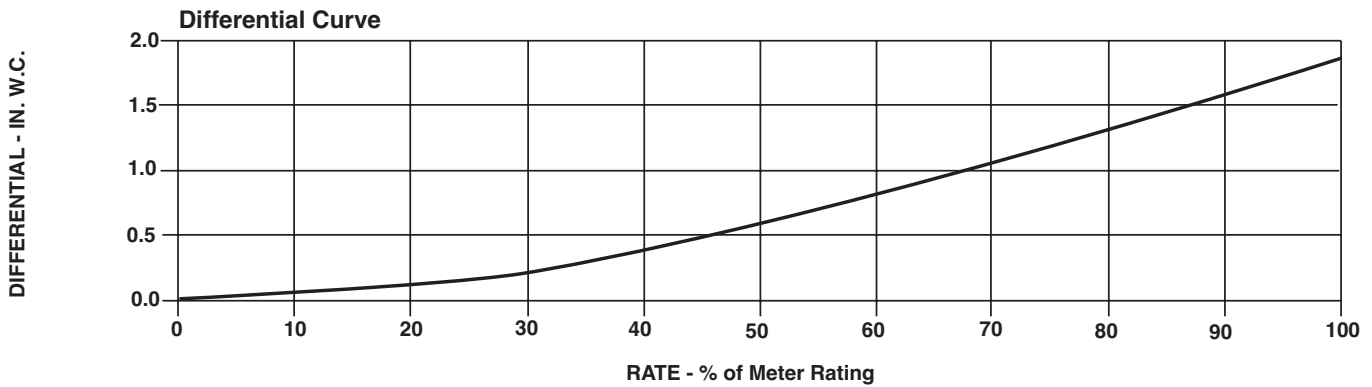
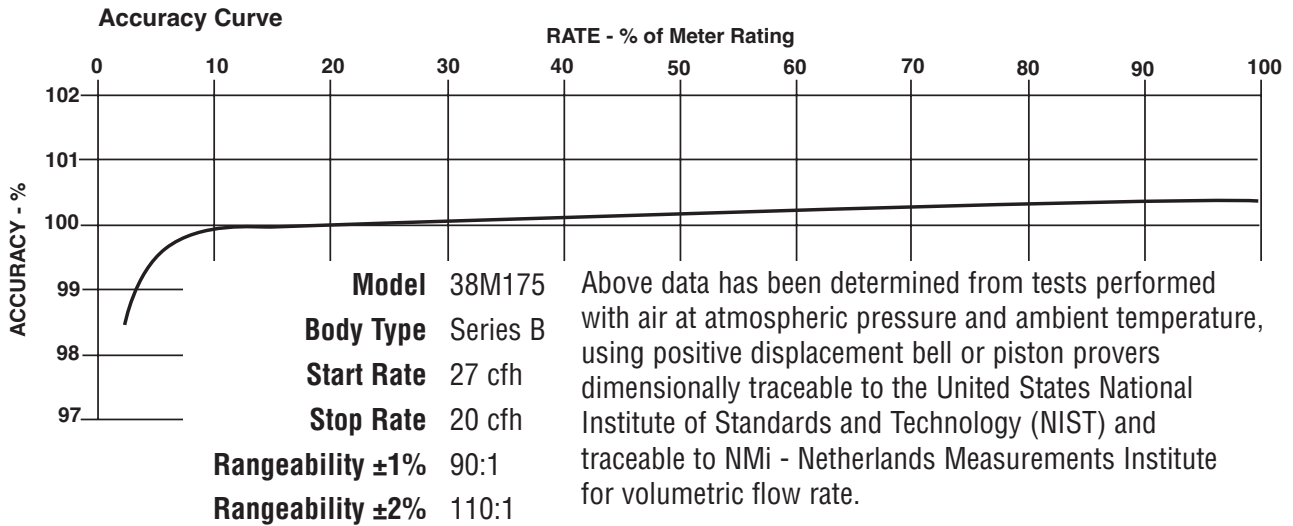

38M175 Series B3	Overall Length		Overall Height		Width (Flange/Flange)		Centerline to Accessory End (CL-AU)		Request Detailed Drawing Number
	inches	mm	inches	mm	inches	mm	inches	mm	
CTR	34-5/8	879	18	457	18	457	14-25/32	375	D054750-001
CD	38-3/16	967	18	457	18	457	23-7/32	590	D054433-001
ICPW/ ITPW/ICEX	36-11/32	923	18	457	18	457	21-3/8	453	D057701-000
IMCW2	39	991	18	457	18	457	24-1/32	610	D057732-000

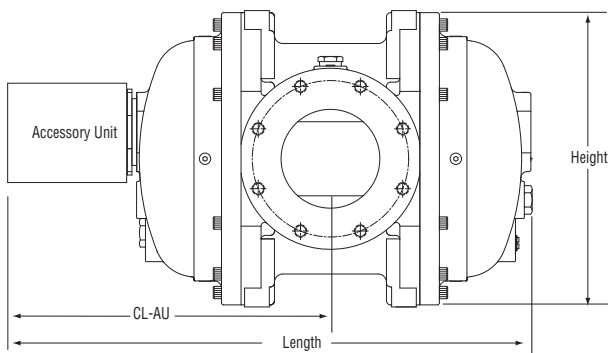

To order

Specify: Meter Series, Size and Type (i.e., ROOTS Meter Series B3 38M175 CD).

For CD, specify Inlet (Top or Side) and ID Rotation (CW-B or CCW-A).

For Pulser, specify Single or Dual Connectors and Connector Type (MS Circular, Conduit or Cable Gland).

For more specific ordering information on the electronic products, request: TS:SSP or TS:IMCW2.

Contact the factory for other available information, options, or special requests.

POWER EQUIPMENT COMPANY
 2011 WILLIAMSBURG ROAD
 RICHMOND, VIRGINIA 23231
 (804) 236-3800 (FAX) (804) 236-3882
 www.peconet.com

