

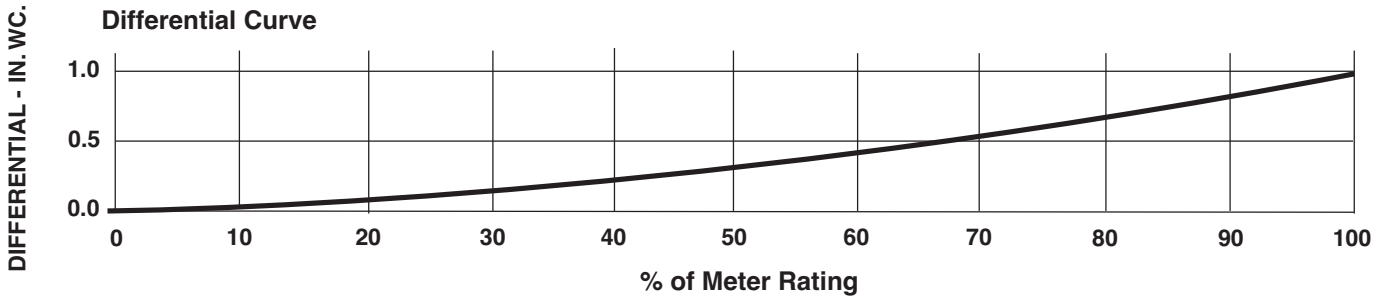

Series B3 ROOTS® Meter 1M300 High Pressure Rotary Meter

	UNITS	Imperial	UNITS	Metric
Temperature Range	deg. F	-40 to +140	deg. C	-40 to +60
Base Rating (Q Max.)	acfh	1000	m ³ /h	28,3
Max. Operating Pressure (MAOP)	psig	300	kPa	2065
Leak Test (125% MAOP)	psig	375	kPa	2575
Static Test (2 x MAOP)	psig	600	kPa	4130
Rangeability +/- 1%	ratio	30:1	ratio	30:1
Rangeability +/- 2%	ratio	59:1	ratio	59:1
Start Rate	cfh	1.9	m ³ /h	0,0538
Stop Rate	cfh	1.1	m ³ /h	0,0311
Flow Rate @ 0.5" w.c., Gas	cfh	>1000	m ³ /h	>28,32
Avg. Differential, 100% Flow	in. w.c.	0.2	mbar	0,5
Max. Pressurization Rate	psig/sec	5	kPa/sec	35
Max. Operating Speed	rpm	834	rpm	834
Gear Ratio	ratio	500:1	ratio	176,4705:1
Displaced Volume/Revolution	cf	0.02	m ³	0,000566
Drive Rate, CD	cf/rev	10	m ³ /rev	0,1
Min. Odometer Reading	cf	0.2	m ³	0,002
Odometer Turnover	yrs.	11.41	yrs.	4,03
Nominal Pipe Size	in.	1-1/2	mm	50,8
Flange-to-Flange	in.	6-3/4	mm	171
Flange Connection	ANSI	300#FF	ANSI	300#FF
Bolts per Flange	qty.	4	qty.	4
Bolt Size ¹	in.	3/4 - 10	in.	3/4 - 10
Flange Bolt Hole Depth	in.	15/16	mm	23,8
Bolt Torque: Lubricated/Non-Lub.	ft.-lb.	55/60	N-m	180
Restricting Orifice (100%)	in.	9/32	mm	7,144
Oil Capacity – Side Inlet	oz.	1.25	ml	37
Oil Capacity – Top Inlet	oz.	7.6	ml	225
<i>Counter Version (CTR)²</i>				
Net Weight	lbs.	26.5	kg	12,0
Shipping Weight	lbs.	28.5	kg	12,9
Carton Size	in.	26 x 10-5/16 x 17	cm	66 x 28 x 20
<i>Counter with Instrument Drive (CD)²</i>				
Net Weight	lbs.	29.5	kg	13,4
Shipping Weight	lbs.	31.5	kg	14,3
Carton Size	in.	14 x 29-3/4 x 11-1/2	cm	36 x 76 x 29

NOTES:¹ Bolt Length varies by application.² Weights and dimensions available for CPS upon request.

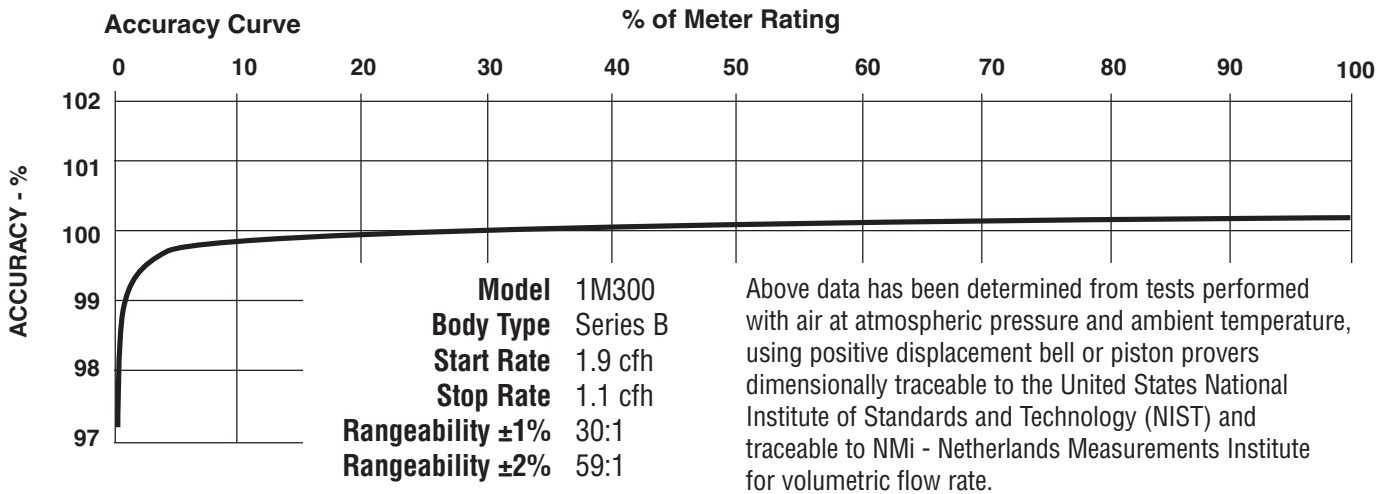

1M300 Series B3	Overall Length		Overall Height		Width (flange/flange)		Centerline to Accessory End (CL-AU)		Request Detailed Drawing Number
	inches	mm	inches	mm	inches	mm	inches	mm	
CTR	15-31/32	406	6-31/32	177	6-3/4	171	10-5/16	262	D054722-000
CD	19-25/32	503	6-31/32	177	6-3/4	171	14-1/8	359	D054439-000
CPW	18-1/16	459	6-31/32	177	6-3/4	171	12-13/32	316	D056121-000

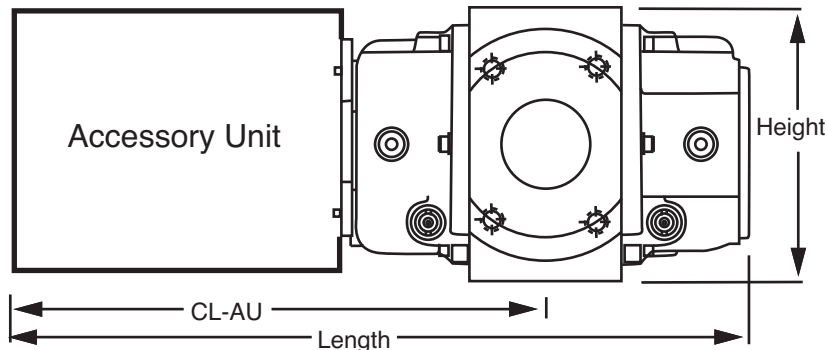

To order

Specify: Meter Series, Size and Type (i.e. ROOTS® Meter Series B3 1M300 CD).
 For CD, specify Inlet (Top or Side) and ID Rotation (CW-B or CCW-A).
 For Pulsar, specify Single or Dual Connectors and Connector Type (MS Circular, Conduit or Cable Gland).
 For more specific ordering information on the electronic products, request: TS:SSP or TS:MC.
 Contact the factory for other available information options, or special requests.

POWER EQUIPMENT COMPANY
 2011 WILLIAMSBURG ROAD
 RICHMOND, VIRGINIA 23231
 (804) 236-3800 (FAX) (804) 236-3882
www.peconet.com



www.dresser.com