

INDUSTRIAL VACUUM COMPONENTS

TUBING, BENDS,
FITTINGS & COUPLINGS



H-P Products, Inc. is an ISO 9002 Certified Company

Services

When Ordering,
Please Specify
Type of Material:

- Carbon
- Stainless
- Aluminum
- Galvanized Steel

INDEX

SERVICES	2-3
TUBING	4
STANDARD ELBOWS & BENDS	
Bending Capabilities	5
Standard Radius Elbows	6
Short Radius Elbows	6
Standard Long Radius Bends	7
FITTINGS	
Standard 90° TY's	8-9
Standard 45° YLs	10-11
Standard Double Y's	12
Standard Reducing Couplings	13
Standard Adapters	14-16
METHODS OF JOINING	
Slip Couplings	17
Shrink Sleeves	17
Wrapped Sleeves	17
METFLO® Compression Couplings	18-19
Cleaner	20
Slip Welding Rings	20
Tube Hangers, Plugs, Nipples	20
ACCESSORIES	
Inlet Valves	21
Escutcheon Plates	21
Valve Accessories	21
Installation Components	22-25

H-P Products, Inc., an ISO 9002 Certified Company, is a leading supplier of tubular components for industrial vacuum systems.

TUBING

Our standard catalog items include tube sizes from 2-1/8" through 14" OD in *Carbon, Stainless, Aluminum and Galvanized Steel*. 1-1/2" and 2" OD are available upon request.

Tube Dimensions

16 Gauge	=	.065"
14 Gauge	=	.083"
12 Gauge	=	.109"
11 Gauge	=	.120"

CATALOG PART VARIATIONS

DELIVERY

Fast delivery is available on a wide selection of in-stock METFLO® Tubing, Bends, Couplings, Fittings and Installation Components. We'll also make every effort to meet emergency requirements for non-stock items.

PRICING

All prices are FOB factory, Louisville, Ohio
Terms: Net 30 days
Prices are in U.S. dollars

Prices and specifications are subject to change without notice, and without obligation. All material is invoiced at the price in effect at time of shipment. All prices and discounts are based on one shipment to one destination. Please see current price list for pricing.

NOTE

Specifications subject to change without notice, without incurring any obligation on our part.

ISO 9002 CERTIFIED

H-P Products, Inc. is ISO 9002 Certified! This accomplishment was achieved after a two-year planning and implementation process to assure that our customers receive the highest quality products and service possible. ISO-9002 defines the correct and proper operation of a company in all aspects of quality, from sales to manufacturing and service. An accredited, third party assessor audited H-P Products to verify compliance with all documented procedures. H-P Products is in select company with few other central vacuum system manufacturers and fabricated air systems tubing suppliers with ISO certification.

*When Ordering,
Please Specify
Type of Material:*

- Carbon
- Stainless
- Aluminum
- Galvanized Steel

INSIDE AND OUTSIDE DIAMETERS POLISHING

Provides smooth ID (180 grit) and OD (150 grit) surfaces. For 2" - 6" OD Long Radius Bends and Straights.

CERAMIC LINING

Ceramic lined parts are used successfully in many pneumatic tube systems conveying highly abrasive materials. This ceramic compound helps many companies save money in material loss, production delays, clean-up and labor costs due to frequency of replacing conventional parts

Specifications

- Available in a single coat thickness (range of .006" to .008")
- Available in a double coat thickness (range of .010" to .012")
- All parts are baked to 1545 degrees F.
- On the Welch Hardness Scale, a scale from 1 to 10, this ceramic lining has a rating of 7. Using this measurement, diamond is the hardest with a rating of 10.
- Only carbon or stainless can be lined (no zinc-coated [galvanized] or aluminum).
- The maximum treatable straight length is 12 feet.

CERAMIC COATING

This wear-resistant ceramic material, is applied to the exterior surface of the part and significantly extends its life in systems conveying highly abrasive material. This special exterior coating helps save money, delays in production, and labor costs.

Specifications

- A wear-resistant ceramic compound, approximately 1/2" thick, is applied to the outside of the tube.
- An exterior fiberglass wrap maintains the grip and strength of the ceramic material.
- Once the interior of the tubular part wears through, the abrasion transfers to the ceramic compound.
- This "ceramic jacket" has a MOHS Hardness of 9, with 10 (diamond), the highest rating on the scale.
- Most of our standard catalog items are available with wear-resistant ceramic coatings
- These parts are modified to provide maximum durability at critical points.

WEB SITE -
WWW.PECONET.COM

Tubing

When Ordering,
Please Specify
Type of Material:

- Carbon
- Stainless
- Aluminum
- Galvanized Steel

Standard Tubing

- 2-1/8" through 14" OD
- Wall Thickness: 16, 14, 12, 11 Gauge
- Materials: Carbon, Stainless, Aluminum, Galvanized Steel

• WE ARE CAPABLE OF PROVIDING 1-1/2" - 14" OD

OD	GAUGE	NOMINAL WALL THICKNESS	CARBON	GALVANIZED STEEL	STAINLESS	ALUMINUM
2-1/8"	16	0.065"	16WT212C	16WT212Z	16WT212S	16ST212A
2-1/8"	11	0.120"	11WT212C	11WT212Z*	11WT212S	11ST212A
2-1/2"	16	0.065"	16WT250C	16WT250Z	16WT250S	16ST250A
2-1/2"	11	0.120"	11WT250C	11WT250Z*	11WT250S	11ST250A
3"	16	0.065"	16WT300C	16WT300Z	16WT300S	16ST300A
3"	11	0.120"	11WT300C	11WT300Z	11WT300S	11ST300A
3-1/2"	16	0.065"	16WT350C	16WT350Z	16WT350S	16ST350A
3-1/2"	11	0.120"	11WT350C	11WT350Z*	11WT350S	11ST350A
4"	16	0.065"	16WT400C	16WT400Z	16WT400S	16ST400A
4"	11	0.120"	11WT400C	11WT400Z	11WT400S	11ST400A
5"	14	0.083"	14WT500C	14WT500Z	14WT500S	14ST500A
5"	11	0.120"	11WT500C	11WT500Z	11WT500S	11ST500A
6"	14	0.083"	14WT600C	14WT600Z	14WT600S	14ST600A
6"	11	0.120"	11WT600C	11WT600Z	11WT600S	11ST600A
8"	14	0.083"	14WT800C	14WT800Z	14WT800S	14ST800A
8"	11	0.120"	11WT800C	11WT800Z	11WT800S	11ST800A
10"	12	0.109"	12WT1000C	12WT1000Z	12WT1000S	12ST1000A†
12"	12	0.109"	12WT1200C	12WT1200Z	12WT1200S	12ST1200A†
14"	12	0.109"	12WT1400C	12WT1400Z	**	**

• OUR STANDARD STOCK (UNLESS NOTED) IS 20 FT. LENGTHS, BUT WE WILL CUT TO YOUR SPECIFICATIONS
 * 10 FT. LENGTHS
 ** QUOTATION BASIS
 † 13 GAUGE

KEY

OD = Outside Diameter
 GALV = Galvanized
 All reference dimensions are nominal.

*When Ordering,
Please Specify
Type of Material:*

- Carbon
- Stainless
- Aluminum
- Galvanized Steel

Standard Specifications

- Inventories include a wide range of parts:
 - Standard Elbows (2-1/2" times OD)
 - Short Radius Elbows (1-1/2" times OD)
 - Long Radius Bends (over 2-1/2" times OD)
- Smooth, wrinkle free elbows
- Wall Thicknesses: 16, 14, 12, (11 Gauge Available in Straight Ends Only)
- (2-1/8" to 4" OD = 16 Gauge) (5" to 8" OD = 14 Gauge) (10" to 14" OD = 12 Gauge)
- Materials: Carbon, Stainless, Aluminum, Galvanized Steel

Tube Bending Capabilities

OD (IN.)	CENTER LINE RADIUS (IN.)	GAUGE	WALL THICKNESS (IN.)
1-1/2	1-3/4, 2-1/2, 3, 3-1/4, 4, 6, 7-1/2, 9, 12, 15, 18, 24, 30, 36	11, 14, 16, 18	.120, .083, .065, .049
1-5/8	2-1/8, 2-1/2	16	.065
1-3/4	2-1/2, 3, 4, 4-1/2, 6, 8, 9, 12, 15, 18, 24, 30, 36	11, 14, 16	.120, .083, .065
2	2, 2-1/2, 3, 3-1/2, 4, 5, 6, 8, 9, 12, 15, 18, 24, 30, 36, 48	11, 14, 16, 18, 20	.120, .083, .065, .049, .035
2-1/8	2-7/8, 3-1/2, 4-1/4, 5, 20, 24, 36	11, 16	.120, .065
2-1/4	2-1/2, 4, 5-1/2, 8, 9, 12, 15, 18, 24, 30, 36, 42	11, 13, 14, 16, 18, 20	.120, .095, .083, .065, .049, .035
2-3/8	2-3/8, 6, 8, 12, 18, 24, 30, 36, 48	16, 18	.065, .049
2-1/2	2-1/2, 3, 3-1/4, 3-3/4, 4, 5, 6, 9, 12, 15, 18, 24, 30, 36, 48	11, 13, 14, 16	.120, .095, .083, .065, .049
2-3/4	2-3/4, 3-7/8, 15, 24, 30	11, 14, 16, 18	.120, .083, .065, .049
2-7/8	9, 10, 10-1/2, 12, 24, 30, 36, 48, 60	15, 16	.072, .065
3	3, 4-1/2, 6, 7-1/2, 9, 12, 15, 18, 24, 30, 36, 38, 48, 60	11, 12, 13, 14, 16, 18	.120, .109, .095, .083, .065, .049
3-1/8	6	16	.065
3-1/2	4, 5, 6, 7-1/2, 8, 8-3/4, 9, 12, 13, 15, 18, 24, 30, 36, 48, 60	11, 14, 15, 16, 18	.120, .083, .072, .065, .049
4	4, 6, 8, 9, 10, 12, 18, 24, 30, 36, 48, 60	10, 11, 14, 16, 18	.134, .120, .083, .065, .049
4-1/4	60	11, 13, 14	.120, .095, .083
4-1/2	9, 12, 16, 20, 24, 30, 36, 48, 60	11, 14, 16	.120, .083, .065
5	5, 5-1/2, 7-1/2, 12-1/2, 18, 24, 30, 36, 48, 60, 72	10, 11, 14, 16	.134, .120, .083, .065
6	7, 9, 15, 24, 30, 36, 48, 60, 72	10, 11, 14, 16	.134, .120, .083, .065
8	12, 20, 32, 48, 60, 72	11, 14	.120, .083
10	20, 32, 48	11, 12	.120, .109

Pipe Bending Capabilities

NPS (INCHES)	OD (INCHES)	CENTER LINE RADIUS (INCHES)	SCHEDULE (INCHES)				
			5	10	40	80	OTHER
1-1/4	1.660	5, 12, 18	-	-	.140	-	-
1-1/2	1.900	6, 9, 12, 18, 36	-	-	.145	-	.200
2	2.375	2-3/8, 6, 8, 12, 18, 24, 30, 36, 48	.065	.109	.154	.218	.218
2-1/2	2.875	9, 10, 10-1/2, 12, 24, 30, 36, 48, 60	.083	.120	.203	.276	-
3	3.500	4, 5, 6, 7-1/2, 8, 8-3/4, 9, 12, 13, 15, 18, 24, 30, 32, 36, 48, 60	.083	.120	.216	.300	.188
3-1/2	4.000	4, 6, 8, 9, 10, 12, 18, 24, 30, 32, 36, 48, 60	.083	.120	-	.300	-
4	4.500	9, 12, 16, 18, 20, 24, 30, 32, 36, 48, 60	.083	.120	.237	.337	.188, .337
5	5.563	24, 30, 36, 48, 60, 72	-	.134	.258	.375	-
6	6.625	24, 30, 36, 48, 60, 72	-	.134	.280	.432	.188, .250
8	8.625	32, 48, 60, 72	-	.148	.322	-	.188, .250

KEY

OD = Outside Diameter
NPS = Nominal Pipe Size
All reference dimensions are nominal.



Standard Elbows & Bends

When Ordering,
Please Specify
Type of Material:

- Carbon
- Stainless
- Aluminum
- Galvanized Steel

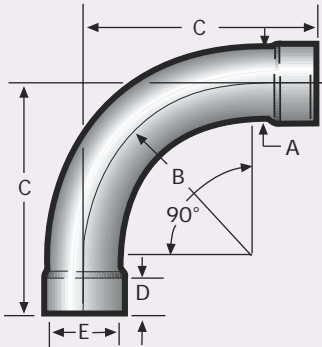

90° Standard Radius Elbow

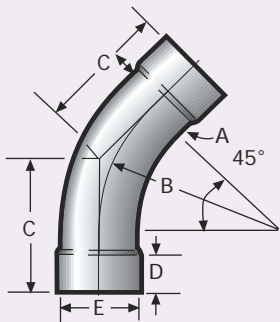

45° Standard Radius Elbow

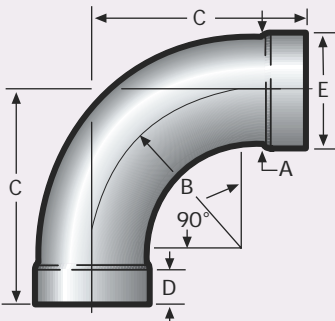

90° Short Radius Elbow

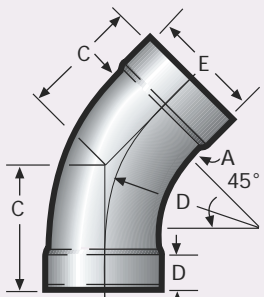

45° Short Radius Elbow

Standard Radius Elbows

- 30° AND 60° ELBOWS AVAILABLE
- 11 GAUGE ELBOWS AVAILABLE (STRAIGHT ENDS ONLY)
- EXPANDED ENDS STANDARD THROUGH 6" SIZE
- EXPANDED ONE END AVAILABLE
- STRAIGHT ENDS AVAILABLE ON ALL SIZES BY REQUEST

A (OD)	B (CLR)	GAUGE	TAN.	C	90° PART NO.	C	45° PART NO.
2-1/8"	5"	16	2"	7"	EL-212	4-5/16"	EL-211
2-1/2"	6"	16	2"	8"	EL-252	4-1/2"	EL-251
3"	7-1/2"	16	2"	9-1/2"	EL-302	5-1/8"	EL-301
3-1/2"	8-3/4"	16	2"	10-1/4"	EL-352	5-5/8"	EL-351
4"	10"	16	2"	12"	EL-402	6-1/8"	EL-401
5"	12-1/2"	14	2-5/8"	15-1/8"	EL-502	7-13/16"	EL-501
6"	15"	14	3-1/4"	18-1/4"	EL-602	9-15/32"	EL-601
8"	20"	14	4-1/4"	24-1/4"	EL-802	12-17/32"	EL-801
10"	32"	12	15"	47"	EL-1002*	28-1/4"	EL-1001*
12"	36"	12	6-1/4"	42-1/4"	EL-1202**	21-5/32"	EL-1201**
14"	36"	12	7-1/4"	43-1/4"	EL-1402**	22-5/32"	EL-1401**

- EXPANSION DEPTH FOR STANDARD AND SHORT RADIUS ELBOWS: 1-1/4" THROUGH 4" OD AND 1-1/2" FOR 5" AND 6" OD
- STAINLESS PARTS (10" OR LARGER OD) ARE SEGMENTED
- * STAINLESS PARTS ARE SEGMENTED
- ** SEGMENTED

Short Radius Elbows

- 30° AND 60° ELBOWS AVAILABLE
- 11 GAUGE ELBOWS AVAILABLE (STRAIGHT ENDS ONLY)
- EXPANDED ENDS STANDARD THROUGH 6" SIZE
- EXPANDED ONE END AVAILABLE
- STRAIGHT ENDS AVAILABLE ON ALL SIZES BY REQUEST

A (OD)	B (CLR)	GAUGE	TAN.	C	90° PART NO.	C	45° PART NO.
2-1/8"	3-1/2"	16	2"	5-1/2"	SR-212	3-7/16"	SR-211
2-1/2"	4"	16	2"	6"	SR-252	3-21/32"	SR-251
3"	4-1/2"	16	2"	6-1/2"	SR-342	3-7/8"	SR-341
3-1/2"	5"	16	2"	7"	SR-352	4-1/16"	SR-351
4"	6"	16	2"	8"	SR-442	4-1/2"	SR-441
5"	7-1/2"	14	2-5/8"	10-1/8"	SR-542	5-23/32"	SR-541
6"	9"	14	3-1/4"	12-1/4"	SR-642	6-31/32"	SR-641
8"	12"	14	4-1/4"	16-1/4"	SR-842	9-7/32"	SR-841

- EXPANSION DEPTH FOR STANDARD AND SHORT RADIUS ELBOWS: 1-1/4" THROUGH 4" OD AND 1-1/2" FOR 5" AND 6" OD

KEY

- OD = Outside Diameter
- CLR = Center Line Radius
- TAN = Tangent Length
- D = Expansion Depth 1-1/4" through 4" OD, 1-1/2" for 5" and 6" OD
- E = Inside Diameter (ID) = A Outside Diameter (OD)
- All reference dimensions are nominal.

When Ordering,
Please Specify
Type of Material:

- Carbon
- Stainless
- Aluminum
- Galvanized Steel

Standard Long Radius Bends

• EXPANDED ENDS AVAILABLE UPON REQUEST, EXCEPT ON 8" AND 10" BENDS & ALL 11 GAUGE BENDS

A (OD)	B (CLR)	GAUGE	C	90° PART NO.	C	45° PART NO.
2-1/8"	24"	16	30"	16-212242	15-15/16"	16-212241
2-1/8"	24"	11	30"	11-212242	15-15/16"	11-212241
2-1/8"	36"	16	42"	16-212362	20-15/16"	16-212361
2-1/8"	36"	11	42"	11-212362	20-15/16"	11-212361
2-1/2"	24"	16	30"	16-250242	15-15/16"	16-250241
2-1/2"	24"	11	30"	11-250242	15-15/16"	11-250241
2-1/2"	36"	16	42"	16-250362	20-15/16"	16-250361
2-1/2"	36"	11	42"	11-250362	20-15/16"	11-250361
3"	24"	16	30"	16-300242	15-15/16"	16-300241
3"	24"	11	30"	11-300242	15-15/16"	11-300241
3"	30"	16	36"	16-300302	18-7/16"	16-300301
3"	30"	11	36"	11-300302	18-7/16"	11-300301
3"	36"	16	42"	16-300362	20-15/16"	16-300361
3"	36"	11	42"	11-300362	20-15/16"	11-300361
3"	38"	16	44"	16-300382	21-3/4"	16-300381
3"	38"	11	44"	11-300382	21-3/4"	11-300381
3"	48"	16	54"	16-300482	25-7/8"	16-300481
3"	48"	11	54"	11-300482	25-7/8"	11-300481
3-1/2"	30"	16	37"	16-350302	19-7/16"	16-350301
3-1/2"	30"	11	37"	11-350302	19-7/16"	11-350301
3-1/2"	36"	16	43"	16-350362	21-15/16"	16-350361
3-1/2"	36"	11	43"	11-350362	21-15/16"	11-350361
3-1/2"	48"	16	55"	16-350482	26-7/8"	16-350481
3-1/2"	48"	11	55"	11-350482	26-7/8"	11-350481
4"	24"	16	32"	16-400242	17-15/16"	16-400241
4"	24"	11	32"	11-400242	17-15/16"	11-400241
4"	30"	16	38"	16-400302	20-7/16"	16-400301
4"	30"	11	38"	11-400302	20-7/16"	11-400301
4"	36"	16	44"	16-400362	22-15/16"	16-400361
4"	36"	11	44"	11-400362	22-15/16"	11-400361
4"	48"	16	56"	16-400482	27-7/8"	16-400481
4"	48"	11	56"	11-400482	27-7/8"	11-400481
4"	60"	16	68"	16-400602	32-7/8"	16-400601
4"	60"	11	68"	11-400602	32-7/8"	11-400601
5"	30"	14	40"	14-500302	22-7/16"	14-500301
5"	30"	11	40"	11-500302	22-7/16"	11-500301
5"	48"	14	58"	14-500482	29-7/8"	14-500481
5"	48"	11	58"	11-500482	29-7/8"	11-500481
6"	30"	14	42"	14-600302	24-7/16"	14-600301
6"	30"	11	42"	11-600302	24-7/16"	11-600301
6"	48"	14	60"	14-600482	31-7/8"	14-600481
6"	48"	11	60"	11-600482	31-7/8"	11-600481
6"	60"	14	72"	14-600602	36-7/8"	14-600601
6"	60"	11	72"	11-600602	36-7/8"	11-600601
8"	32"	14	48"	14-800322	25-1/4"	14-800321
8"	32"	11	48"	11-800322	25-1/4"	11-800321
8"	48"	14	64"	14-800482	31-7/8"	14-800481
8"	48"	11	64"	11-800482	31-7/8"	11-800481
10"	48"	12	70"	12-1000482*	41-7/8"	12-1000481*

- NOMINAL STANDARD TANGENT IS TWO TIMES TUBE OD, 6" MINIMUM
- ALL STANDARD BENDS HAVE STRAIGHT ENDS
- NOMINAL STANDARD TANGENT FOR 10" BEND IS 22"
- * STAINLESS PARTS ARE SEGMENTED

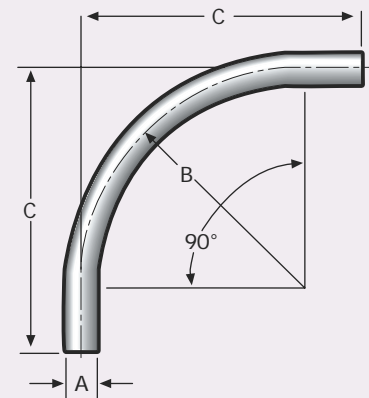

90° Long Radius Bend

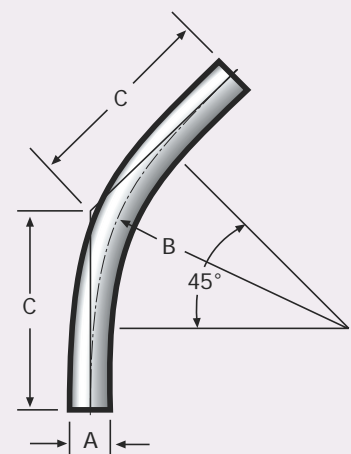

45° Long Radius Bend

KEY

OD = Outside Diameter
CLR = Center Line Radius
C = Center to end
All reference dimensions are nominal.

Fittings

When Ordering,
Please Specify
Type of Material:

- Carbon
- Stainless
- Aluminum
- Galvanized Steel

Standard 90° TY's

- 2-1/8" through 14" OD
- Wall Thickness: 16, 14, 12, (11 Gauge Available in Straight Ends Only)
- (16 Gauge: 2-1/8" to 4" OD) (14 Gauge: 5" to 8" OD) (12 Gauge: 10" to 14" OD)
- Materials: Carbon, Stainless, Aluminum, Galvanized Steel

- 11 GAUGE TY'S AVAILABLE (STRAIGHT ENDS ONLY)
- STRAIGHT AND EXPANDED COMBINATIONS AVAILABLE
- STRAIGHT ENDS AVAILABLE ON ALL SIZES BY REQUEST

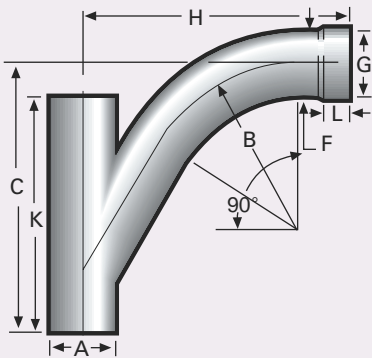

90° TY
(one end expanded)

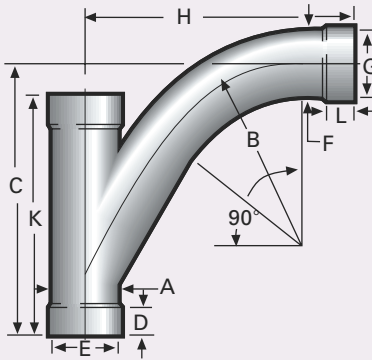

90° TY
(three ends expanded)

KEY

OD = Outside Diameter
D = Expansion Depth 1-1/4"
through 4" OD, 1-1/2" for
5" and 6" OD
A = Outside Diameter (OD) = E
Inside Diameter (ID)
F = Outside Diameter (OD) = G
Inside Diameter (ID)
L = Expansion Depth 1-1/4"
through 4" OD, 1-1/2" for
5" and 6" OD

All reference dimensions are
nominal.

SIZE	GAUGE	A (OD)	B	C	F (OD)	H	K	PART NO.
2-1/8"	16	2-1/8"	5"	9-5/32"	2-1/8"	8-13/16"	9-1/2"	TY-215
2-1/2" x 2-1/8"	16	2-1/2"	5"	9-11/32"	2-1/8"	9"	10"	TY-255
2-1/2"	16	2-1/2"	6"	10-1/2"	2-1/2"	10-1/32"	10"	TY-256
3" x 2-1/8"	16	3"	5"	9-19/32"	2-1/8"	9-1/4"	10-1/2"	TY-305
3" x 2-1/2"	16	3"	6"	10-3/4"	2-1/2"	10-9/32"	10-1/2"	TY-306
3"	16	3"	7-1/2"	12-3/8"	3"	11-25/32"	11-1/2"	TY-307
3-1/2" x 2-1/8"	16	3-1/2"	5"	9-27/32"	2-1/8"	9-1/2"	11"	TY-355
3-1/2" x 2-1/2"	16	3-1/2"	6"	11"	2-1/2"	10-17/32"	11"	TY-356
3-1/2" x 3"	16	3-1/2"	7-1/2"	12-5/8"	3"	12-1/32"	13"	TY-357
3-1/2"	16	3-1/2"	8-3/4"	14-1/8"	3-1/2"	13-11/32"	13"	TY-358
4" x 2-1/8"	16	4"	5"	10-3/32"	2-1/8"	9-3/4"	12"	TY-405
4" x 2-1/2"	16	4"	6"	11-1/4"	2-1/2"	10-25/32"	12"	TY-406
4" x 3"	16	4"	7-1/2"	12-7/8"	3"	12-9/32"	12"	TY-407
4" x 3-1/2"	16	4"	8-3/4"	14-3/8"	3-1/2"	13-19/32"	14"	TY-408
4"	16	4"	10"	15-7/8"	4"	14-29/32"	14"	TY-409
5" x 2-1/8"	14	5"	5"	10-19/32"	2-1/8"	10-1/4"	13"	TY-505
5" x 2-1/2"	14	5"	6"	11-3/4"	2-1/2"	11-9/32"	13"	TY-506
5" x 3"	14	5"	7-1/2"	13-3/8"	3"	12-25/32"	15-1/2"	TY-507
5" x 3-1/2"	14	5"	8-3/4"	14-7/8"	3-1/2"	14-3/32"	15-1/2"	TY-508
5" x 4"	14	5"	10"	16-3/8"	4"	15-13/32"	15-1/2"	TY-509
5"	14	5"	12-1/2"	19-3/8"	5"	18-5/8"	18-1/2"	TY-515
6" x 2-1/8"	14	6"	5"	11-3/32"	2-1/8"	10-3/4"	15"	TY-605
6" x 2-1/2"	14	6"	6"	12-1/4"	2-1/2"	11-25/32"	15"	TY-606
6" x 3"	14	6"	7-1/2"	13-7/8"	3"	13-9/32"	15"	TY-607
6" x 3-1/2"	14	6"	8-3/4"	15-3/8"	3-1/2"	14-19/32"	17"	TY-608
6" x 4"	14	6"	10"	16-7/8"	4"	15-29/32"	17"	TY-609
6" x 5"	14	6"	12-1/2"	19-7/8"	5"	19-1/8"	21"	TY-614
6"	14	6"	15"	22-7/8"	6"	22-11/32"	21"	TY-615
8" x 2-1/8"	14	8"	5"	12-3/32"	2-1/8"	11-3/4"	18"	TY-805
8" x 2-1/2"	14	8"	6"	13-1/4"	2-1/2"	12-25/32"	18"	TY-806
8" x 3"	14	8"	7-1/2"	14-7/8"	3"	14-9/32"	18"	TY-807
8" x 3-1/2"	14	8"	8-3/4"	16-3/8"	3-1/2"	15-19/32"	21"	TY-808
8" x 4"	14	8"	10"	17-7/8"	4"	16-29/32"	21"	TY-809
8" x 5"	14	8"	12-1/2"	20-7/8"	5"	20-1/8"	24"	TY-814
8" x 6"	14	8"	15"	23-7/8"	6"	23-11/32"	24"	TY-815
8"	14	8"	20"	29-7/8"	8"	29-17/32"	29"	TY-816
10" x 2-1/8"	12	10"	5"	13-3/32"	2-1/8"	12-3/4"	21"	TY-1005

- EXPANDED ENDS STANDARD THROUGH 6" SIZE
- * SEGMENTED

When Ordering,
Please Specify
Type of Material:

- Carbon
- Stainless
- Aluminum
- Galvanized Steel

Standard 90° TY's - cont.

- 11 GAUGE TY'S AVAILABLE (STRAIGHT ENDS ONLY)
- STRAIGHT AND EXPANDED COMBINATIONS AVAILABLE
- STRAIGHT ENDS AVAILABLE ON ALL SIZES BY REQUEST

SIZE	GAUGE	A (OD)	B	C	F (OD)	H	K	PART NO.
10" x 2-1/2"	12	10"	6"	14-1/4"	2-1/2"	13-25/32"	21"	TY-1006
10" x 3"	12	10"	7-1/2"	15-7/8"	3"	15-9/32"	21"	TY-1007
10" x 3-1/2"	12	10"	8-3/4"	17-3/8"	3-1/2"	16-17/32"	24"	TY-1008
10" x 4"	12	10"	10"	18-7/8"	4"	17-29/32"	24"	TY-1009
10" x 5"	12	10"	12-1/2"	21-7/8"	5"	21-1/8"	24"	TY-1014
10" x 6"	12	10"	15"	24-7/8"	6"	24-11/32"	28"	TY-1015
10" x 8"	12	10"	20"	30-7/8"	8"	30-17/32"	32"	TY-1016
10"	12	10"	32"	40-3/8"	10"	42-25/32"	36"	TY-1017
12" x 2-1/8"	12	12"	5"	14-3/32"	2-1/8"	13-3/4"	24"	TY-1205
12" x 2-1/2"	12	12"	6"	15-1/4"	2-1/2"	14-25/32"	24"	TY-1206
12" x 3"	12	12"	7-1/2"	16-7/8"	3"	16-9/32"	24"	TY-1207
12" x 3-1/2"	12	12"	8-3/4"	18-3/8"	3-1/2"	17-19/32"	27"	TY-1208
12" x 4"	12	12"	10"	19-7/8"	4"	18-29/32"	27"	TY-1209
12" x 5"	12	12"	12-1/2"	22-7/8"	5"	22-1/8"	27"	TY-1214
12" x 6"	12	12"	15"	25-7/8"	6"	25-11/32"	31"	TY-1215
12" x 8"	12	12"	20"	31-7/8"	8"	31-17/32"	35"	TY-1216
12" x 10"	12	12"	32"	41-3/8"	10"	43-25/32"	39"	TY-1217
12"	12	12"	36"*	46-7/8"	12"	49-1/8"	43"	TY-1218
14" x 8"	12	14"	20"	32-7/8"	8"	32-17/23"	38"	TY-1416
14" x 10"	12	14"	32"	42-3/8"	10"	44-25/32"	42"	TY-1417
14" x 12"	12	14"	36"*	47-7/8"	12"	50-1/8"	46"	TY-1418
14"	12	14"	36"*	51-3/8"	14"	50-3/4"	52"	TY-1419

- EXPANDED ENDS STANDARD THROUGH 6" SIZE
- * SEGMENTED

KEY

OD = Outside Diameter
 F = Outside Diameter (OD) = G = Inside Diameter (ID)
 L = Expansion Depth 1-1/4" through 4" OD, 1-1/2" for 5" and 6" OD
 All reference dimensions are nominal.

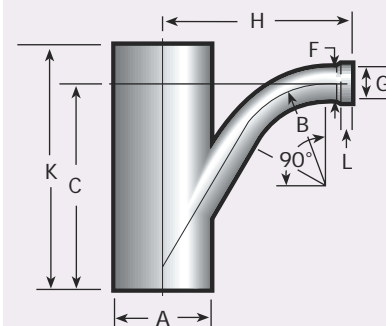

90° TY
(one end expanded)

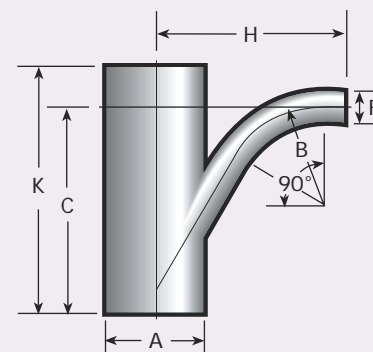

90° TY
(straight ends)

Fittings

When Ordering,
Please Specify
Type of Material:

- Carbon
- Stainless
- Aluminum
- Galvanized Steel

Standard 45° YL's

- 2-1/8" through 14" OD
- Wall Thickness: 16, 14, 12, (11 Gauge Available in Straight Ends Only)
- (16 Gauge: 2-1/8" to 4" OD) (14 Gauge: 5" to 8" OD) (12 Gauge: 10" to 14" OD)
- Materials: Carbon, Stainless, Aluminum, Galvanized Steel

- 11 GAUGE YL'S AVAILABLE (STRAIGHT ENDS ONLY)
- STRAIGHT AND EXPANDED COMBINATIONS AVAILABLE
- STRAIGHT ENDS AVAILABLE ON ALL SIZES BY REQUEST

SIZE	GAUGE	A (OD)	B	C	F (OD)	H	K	PART NO.
2-1/8"	16	2-1/8"	5"	9-3/32"	2-1/8"	4-11/16"	9-1/2"	YL-2151
2-1/2" X 2-1/8"	16	2-1/2"	5"	9-9/32"	2-1/8"	4-7/8"	10"	YL-2551
2-1/2"	16	2-1/2"	6"	10-5/32"	2-1/2"	5-3/16"	10"	YL-2561
3" X 2-1/8"	16	3"	5"	9-17/32"	2-1/8"	5-1/8"	10-1/2"	YL-3051
3" X 2-1/2"	16	3"	6"	10-13/32"	2-1/2"	5-7/16"	10-1/2"	YL-3061
3"	16	3"	7-1/2"	11-19/32"	3"	5-29/32"	11-1/2"	YL-3071
3-1/2" X 2-1/8"	16	3-1/2"	5"	9-25/32"	2-1/8"	5-3/8"	11"	YL-3551
3-1/2" X 2-1/2"	16	3-1/2"	6"	10-21/32"	2-1/2"	5-11/16"	11"	YL-3561
3-1/2" X 3"	16	3-1/2"	7-1/2"	11-27/32"	3"	6-5/32"	13"	YL-3571
3-1/2"	16	3-1/2"	8-3/4"	12-31/32"	3-1/2"	6-9/16"	13"	YL-3581
4" X 2-1/8"	16	4"	5"	10-1/32"	2-1/8"	5-5/8"	12"	YL-4051
4" X 2-1/2"	16	4"	6"	10-29/32"	2-1/2"	5-15/16"	12"	YL-4061
4" X 3"	16	4"	7-1/2"	12-3/32"	3"	6-13/32"	12"	YL-4071
4" X 3-1/2"	16	4"	8-3/4"	13-7/32"	3-1/2"	6-13/16"	14"	YL-4081
4"	16	4"	10"	14-11/32"	4"	7-1/4"	14"	YL-4091
5" X 2-1/8"	14	5"	5"	10-17/32"	2-1/8"	6-1/8"	13"	YL-5051
5" X 2-1/2"	14	5"	6"	11-13/32"	2-1/2"	6-7/16"	13"	YL-5061
5" X 3"	14	5"	7-1/2"	12-19/32"	3"	6-29/32"	15-1/2"	YL-5071
5" X 3-1/2"	14	5"	8-3/4"	13-23/32"	3-1/2"	7-5/16"	15-1/2"	YL-5081
5" X 4"	14	5"	10"	14-27/32"	4"	7-3/4"	15-1/2"	YL-5091
5"	14	5"	12-1/2"	17-9/16"	5"	9"	18-1/2"	YL-5151
6" X 2-1/8"	14	6"	5"	11-1/32"	2-1/8"	6-5/8"	15"	YL-6051
6" X 2-1/2"	14	6"	6"	11-29/32"	2-1/2"	6-15/16"	15"	YL-6061
6" X 3"	14	6"	7-1/2"	13-3/32"	3"	7-13/32"	15"	YL-6071
6" X 3-1/2"	14	6"	8-3/4"	14-7/32"	3-1/2"	7-13/16"	17"	YL-6081
6" X 4"	14	6"	10"	15-11/32"	4"	8-1/4"	17"	YL-6091
6" X 5"	14	6"	12-1/2"	18-1/16"	5"	9-1/2"	21"	YL-6141
6"	14	6"	15"	20-25/32"	6"	10-25/32"	21"	YL-6151
8" X 2-1/8"	14	8"	5"	12-1/32"	2-1/8"	7-5/8"	18"	YL-8051
8" X 2-1/2"	14	8"	6"	12-29/32"	2-1/2"	7-15/16"	18"	YL-8061
8" X 3"	14	8"	7-1/2"	14-3/32"	3"	8-13/32"	18"	YL-8071
8" X 3-1/2"	14	8"	8-3/4"	15-7/32"	3-1/2"	8-13/16"	21"	YL-8081
8" X 4"	14	8"	10"	16-11/32"	4"	9-1/4"	21"	YL-8091
8" X 5"	14	8"	12-1/2"	19-1/16"	5"	10-1/2"	24"	YL-8141
8" X 6"	14	8"	15"	21-25/32"	6"	11-25/32"	24"	YL-8151
8"	14	8"	20"	27"	8"	14-5/32"	29"	YL-8161
10" X 2-1/8"	12	10"	5"	13-1/32"	2-1/8"	8-5/8"	21"	YL-10051

- EXPANDED ENDS STANDARD THROUGH 6" SIZE
- * SEGMENTED

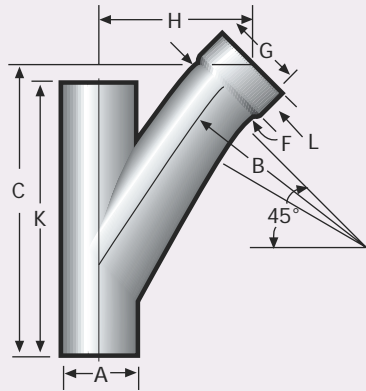

45° YL
(one end expanded)

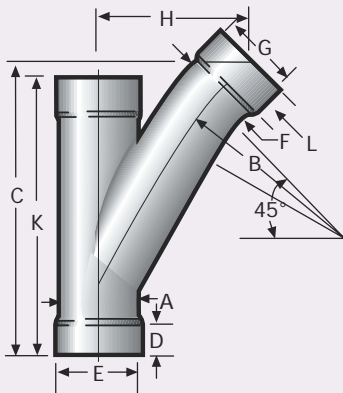

45° YL
(three ends expanded)

OD = Outside Diameter
 D = Expansion Depth 1-1/4"
 through 4" OD, 1-1/2" for
 5" and 6" OD
 A = Outside Diameter (OD) = E
 Inside Diameter (ID)
 F = Outside Diameter (OD) = G
 Inside Diameter (ID)
 L = Expansion Depth 1-1/4"
 through 4" OD, 1-1/2" for
 5" and 6" OD

All reference dimensions are
 nominal.

When Ordering,
Please Specify
Type of Material:

- Carbon
- Stainless
- Aluminum
- Galvanized Steel

Standard 45° YL's - cont.

- 11 GAUGE YL'S AVAILABLE (STRAIGHT ENDS ONLY)
- STRAIGHT AND EXPANDED COMBINATIONS AVAILABLE
- STRAIGHT ENDS AVAILABLE ON ALL SIZES BY REQUEST

SIZE	GAUGE	A (OD)	B	C	F (OD)	H	K	PART NO.
10" X 2-1/2"	12	10"	6"	13-29/32"	2-1/2"	8-15/16"	21"	YL-10061
10" X 3"	12	10"	7-1/2"	15-3/32"	3"	9-13/32"	21"	YL-10071
10" X 3-1/2"	12	10"	8-3/4"	16-7/32"	3-1/2"	9-13/16"	24"	YL-10081
10" X 4"	12	10"	10"	17-11/32"	4"	10-1/4"	24"	YL-10091
10" X 5"	12	10"	12-1/2"	20-1/16"	5"	11-1/2"	24"	YL-10141
10" X 6"	12	10"	15"	22-3/4"	6"	12-25/32"	28"	YL-10151
10" X 8"	12	10"	20"	28"	8"	15-5/32"	32"	YL-10161
10"	12	10"	32"	34-11/16"	10"	18-5/8"	36"	YL-10171
12" X 2-1/8"	12	12"	5"	14-1/32"	2-1/8"	9-5/8"	24"	YL-12051
12" X 2-1/2"	12	12"	6"	14-29/32"	2-1/2"	9-31/32"	24"	YL-12061
12" X 3"	12	12"	7-1/2"	16-3/32"	3"	10-13/32"	24"	YL-12071
12" X 3-1/2"	12	12"	8-3/4"	17-7/32"	3-1/2"	10-13/16"	27"	YL-12081
12" X 4"	12	12"	10"	18-11/32"	4"	11-1/4"	27"	YL-12091
12" X 5"	12	12"	12-1/2"	21-1/16"	5"	12-1/2"	27"	YL-12141
12" X 6"	12	12"	15"	23-3/4"	6"	13-25/32"	31"	YL-12151
12" X 8"	12	12"	20"	29"	8"	16-5/32"	35"	YL-12161
12" X 10"	12	12"	32"	35-11/16"	10"	19-5/8"	39"	YL-12171
12"	12	12"	36**	40-3/4"	12"	21-27/32"	43"	YL-12181
14" X 8"	12	14"	20"	30"	8"	17-5/32"	38"	YL-14161
14" X 10"	12	14"	32"	36-11/32"	10"	20-5/8"	42"	YL-14171
14" X 12"	12	14"	36**	41-3/4"	12"	22-27/32"	46"	YL-14181
14"	12	14"	36**	45-15/16"	14"	24-13/32"	52"	YL-14191

- EXPANDED ENDS STANDARD THROUGH 6" SIZE
- * SEGMENTED

KEY

OD = Outside Diameter
 F = Outside Diameter (OD) = G = Inside Diameter
 L = Expansion Depth 1-1/4" through 4" OD, 1-1/2" for 5" and 6" OD
 All reference dimensions are nominal.

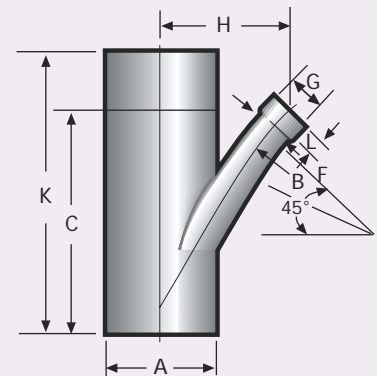

45° YL
(one end expanded)

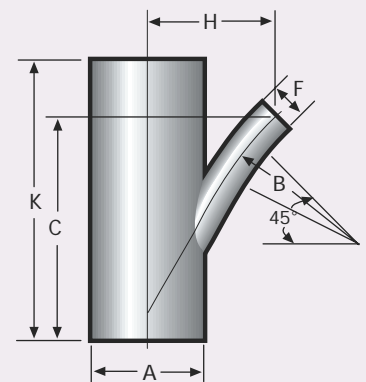

45° YL
(straight ends)

Fittings

When Ordering,
Please Specify
Type of Material:

- Carbon
- Stainless
- Aluminum
- Galvanized Steel

Standard Double Y's

- 2-1/8" through 6" OD
- Wall Thickness: 16, 14, (11 Gauge Available in Straight Ends Only)
- (16 Gauge: 2-1/8" to 4" OD) (14 Gauge: 5" to 6" OD)
- Materials: Carbon, Stainless, Aluminum, Galvanized Steel

Standard Double 90° TY's

- 11 GAUGE Y'S AVAILABLE (STRAIGHT ENDS ONLY)
- STRAIGHT AND EXPANDED COMBINATIONS AVAILABLE
- STRAIGHT ENDS AVAILABLE ON ALL SIZES BY REQUEST

SIZE	GAUGE	A (OD)	B	C	F (OD)	H	K	PART NO.
2-1/8"	16	2-1/8"	5"	9-5/32"	2-1/8"	8-13/16"	9-1/2"	DTY-215
2-1/2"	16	2-1/2"	6"	10-1/2"	2-1/2"	10-1/32"	10"	DTY-256
3"	16	3"	7-1/2"	12-3/8"	3"	11-25/32"	11-1/2"	DTY-307
3-1/2"	16	3-1/2"	8-3/4"	14-1/8"	3-1/2"	13-11/32"	13"	DTY-358
4"	16	4"	10"	15-7/8"	4"	14-29/32"	14"	DTY-409
5"	14	5"	12-1/2"	19-3/8"	5"	18-5/8"	18-1/2"	DTY-515
6"	14	6"	15"	22-7/8"	6"	22-11/32"	21"	DTY-615

- EXPANDED ENDS STANDARD

Standard Double 45° YL's

- 11 GAUGE Y'S AVAILABLE (STRAIGHT ENDS ONLY)
- STRAIGHT AND EXPANDED COMBINATIONS AVAILABLE
- STRAIGHT ENDS AVAILABLE ON ALL SIZES BY REQUEST

SIZE	GAUGE	A (OD)	B	C	F (OD)	H	K	PART NO.
2-1/8"	16	2-1/8"	5"	9-3/32"	2-1/8"	4-11/16"	9-1/2"	DYL-2151
2-1/2"	16	2-1/2"	6"	10-5/32"	2-1/2"	5-3/16"	10"	DYL-2561
3"	16	3"	7-1/2"	11-19/32"	3"	5-29/32"	11-1/2"	DYL-3071
3-1/2"	16	3-1/2"	8-3/4"	12-31/32"	3-1/2"	6-9/16"	13"	DYL-3581
4"	16	4"	10"	14-11/32"	4"	7-1/4"	14"	DYL-4091
5"	14	5"	12-1/2"	17-9/16"	5"	9"	18-1/2"	DYL-5151
6"	14	6"	15"	20-25/32"	6"	10-15/32"	21"	DYL-6151

- EXPANDED ENDS STANDARD

Standard Double 90° Y's

- 11 GAUGE Y'S AVAILABLE (STRAIGHT ENDS ONLY)
- STRAIGHT AND EXPANDED COMBINATIONS AVAILABLE
- STRAIGHT ENDS AVAILABLE ON ALL SIZES BY REQUEST

SIZE	GAUGE	A (OD)	B	C	F (OD)	H	K	PART NO.
2-1/8"	16	2-1/8"	5"	7"	2-1/8"	7"	-	DY-215
2-1/2"	16	2-1/2"	6"	8"	2-1/2"	8"	-	DY-256
3"	16	3"	7-1/2"	9-1/2"	3"	9-1/2"	-	DY-307
3-1/2"	16	3-1/2"	8-3/4"	10-3/4"	3-1/2"	10-3/4"	-	DY-358
4"	16	4"	10"	12"	4"	12"	-	DY-409
5"	14	5"	12-1/2"	15-1/8"	5"	15-1/8"	-	DY-515
6"	14	6"	15"	18-1/4"	6"	18-1/4"	-	DY-615

- EXPANDED ENDS STANDARD

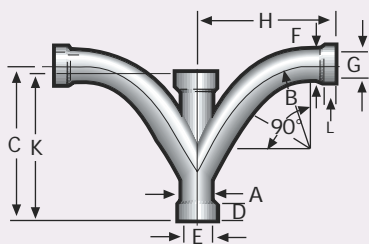

Standard Double 90° TY

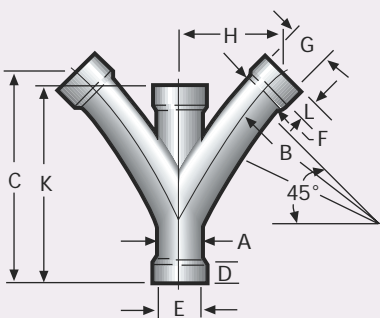

Standard Double 45° YL

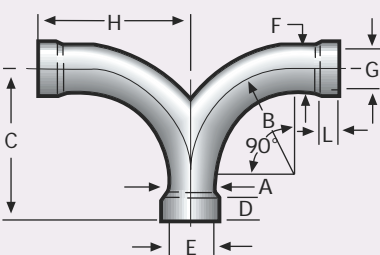

Standard Double 90° Y

KEY

OD = Outside Diameter
 D = Expansion Depth 1-1/4" through
 4" OD, 1-1/2" for 5" and 6" OD
 A = Outside Diameter (OD) = E - Inside
 Diameter (ID)
 F = Outside Diameter (OD) = G - Inside
 Diameter (ID)
 L = Expansion Depth 1-1/4" through
 4" OD, 1-1/2" for 5" and 6" OD
 All reference dimensions are nominal.

When Ordering,
Please Specify
Type of Material:

- Carbon
- Stainless
- Aluminum
- Galvanized Steel

Standard Reducing Couplings

- 2-1/8" through 14" OD
- Wall Thickness: 16, 14, 12, (11 Gauge Available in Straight Ends Only)
- Materials: Carbon, Stainless, Aluminum, Galvanized Steel

- 11 GAUGE AVAILABLE (STRAIGHT ENDS ONLY)
- STRAIGHT ENDS AVAILABLE ON ALL SIZES BY REQUEST

SIZE	GAUGE	A (OD)	C	D	E (ID) / F (OD)	GAUGE	K	PART NO.
2-1/8" x 2"	16	2-1/8"	4"	1-1/8"	2" ID	16	2"	RC-212
2-1/2" x 2-1/8"	16	2-1/2"	4-1/2"	1-1/4"	2-1/8" ID	16	1-1/2"	RC-254
3" x 2-1/8"	16	3"	8-3/4"	1-1/4"	2-1/8" ID	16	2"	RC-3041
3" x 2-1/2"	16	3"	5"	1-1/4"	2-1/2" ID	16	1-1/2"	RC-304
3-1/2" X 2-1/8"	16	3-1/2"	11"	1-1/4"	2-1/8" ID	16	2"	RC-3541
3-1/2" X 2-1/2"	16	3-1/2"	9-1/4"	1-1/4"	2-1/2" ID	16	2-7/8"	RC-3542
3-1/2" X 3"	16	3-1/2"	5-1/2"	1-1/4"	3" ID	16	1-1/2"	RC-354
4" X 2-1/8"	16	4"	13-1/2"	1-1/4"	2-1/8" ID	16	2"	RC-4041
4" X 2-1/2"	16	4"	10-1/2"	1-1/4"	2-1/2" ID	16	2"	RC-4042
4" X 3"	16	4"	9-1/4"	1-1/4"	3" ID	16	2"	RC-4043
4" X 3-1/2"	16	4"	6"	1-1/4"	3-1/2" ID	16	1-1/2"	RC-404
5" X 2-1/8"	14	5"	19-1/4"	1-1/4"	2-1/8" ID	16	2-3/4"	RC-5041
5" X 2-1/2"	14	5"	17-1/2"	1-1/4"	2-1/2" ID	16	2-3/4"	RC-5042
5" X 3"	14	5"	15"	1-1/4"	3" ID	16	2-3/4"	RC-5043
5" X 3-1/2"	14	5"	12-1/2"	1-1/4"	3-1/2" ID	16	2-3/4"	RC-5044
5" X 4"	16	5"	8"	1-1/4"	4" ID	16	1-3/4"	RC-504
6" X 2-1/8"	14	6"	24-3/4"	1-1/4"	2-1/8" ID	16	3-1/4"	RC-6041
6" X 2-1/2"	14	6"	23"	1-1/4"	2-1/2" ID	16	3-1/4"	RC-6042
6" X 3"	14	6"	20-1/2"	1-1/4"	3" ID	16	3-1/4"	RC-6043
6" X 3-1/2"	14	6"	18"	1-1/4"	3-1/2" ID	16	3-1/4"	RC-6044
6" X 4"	14	6"	15-3/4"	1-1/4"	4" ID	16	3-1/4"	RC-6045
6" X 5"	14	6"	10"	1-1/2"	5" ID	14	1-3/4"	RC-604
8" X 4"	14	8"	26-1/4"	1-1/4"	4" ID	16	4-1/4"	RC-8044
8" X 5"	14	8"	21-7/8"	1-1/2"	5" ID	14	4-1/4"	RC-8045
8" X 6"	14	8"	17-1/2"	1-1/2"	6" ID	14	3-5/8"	RC-804
10" X 6"	12	10"	28-1/2"	1-1/2"	6" ID	14	5-1/4"	RC-10046
10" X 8"	12	10"	18-1/4"	2-1/2"	8" OD	14	5-1/4"	RC-1004
12" X 8"	12	12"	29-1/4"	2-1/2"	8" OD	14	6-1/4"	RC-12048
12" X 10"	12	12"	19-3/4"	3"	10" OD	12	6-1/4"	RC-1204
14" X 10"	12	14"	30"	3"	10" OD	12	7-1/4"	RC-1404
14" X 12"	12	14"	20"	4"	12" OD	12	7-1/4"	RC-1405

- EXPANDED ENDS STANDARD THROUGH 6" SIZE (ON SMALL END OF REDUCER)

KEY

OD = Outside Diameter

ID = Inside Diameter

All reference dimensions are nominal.

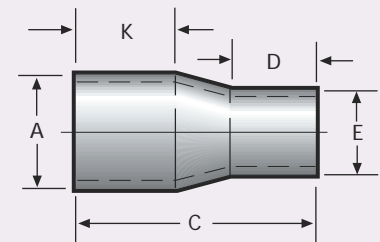

Standard Reducing Coupling
(straight end)

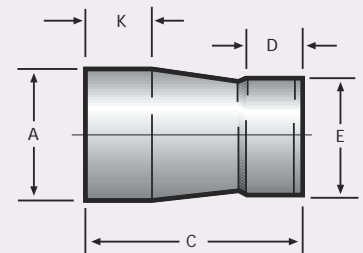

Standard Reducing Coupling
(expanded end)

Fittings

When Ordering,
Please Specify
Type of Material:

- Carbon
- Stainless
- Aluminum
- Galvanized Steel

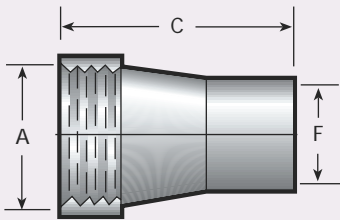

Female Adapter

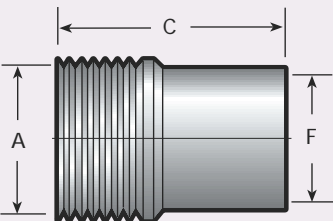

Male Adapter

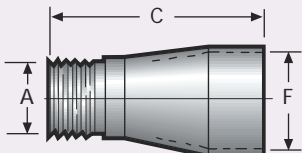

Male Adapter

Standard Adapters

Female and Male Adapters

- 2" to 12"
- Wall Thickness: 16, 14, 12, 11 Gauge
- Materials: Carbon, Stainless, Aluminum, Galvanized Steel

Female Adapters

• 11 GAUGE AVAILABLE

SIZE	GAUGE	A-FNPT	C	F (OD)	PART NO.
2" to 2"	16	2"	6"	2"	FA-201
2" to 2-1/8"	16	2"	6"	2-1/8"	FA-211
2-1/2" to 2-1/2"	16	2-1/2"	6"	2-1/2"	FA-251
3" to 3"	16	3"	6"	3"	FA-301
3-1/2" to 3-1/2"	16	3-1/2"	6"	3-1/2"	FA-351
4" to 4"	16	4"	6-1/2"	4"	FA-401
5" to 5"	14	5"	6-3/4"	5"	FA-501
6" to 6"	14	6"	7"	6"	FA-601
8" to 8"	14	8"	9"	8"	FA-801
10" to 10"	12	10"	11"	10"	FA-1001
12" to 12"	12	12"	13"	12"	FA-1201

Male Adapters

• 11 GAUGE AVAILABLE

SIZE	GAUGE	A-MNPT	C	F (OD)	PART NO.
2" to 2"	16	2"	6"	2"	MA-202
2" to 2-1/8"	16	2"	6"	2-1/8"	MA-212
2-1/2" to 2-1/2"	16	2-1/2"	6"	2-1/2"	MA-252
3" to 3"	16	3"	6"	3"	MA-302
3-1/2" to 3-1/2"	16	3-1/2"	6"	3-1/2"	MA-352
4" to 4"	16	4"	6"	4"	MA-402
5" to 5"	14	5"	6-1/2"	5"	MA-502
6" to 6"	14	6"	7"	6"	MA-602
8" to 8"	14	8"	8"	8"	MA-802
10" to 10"	12	10"	8-1/2"	10"	MA-1002
12" to 12"	12	12"	9"	12"	MA-1202

Male Adapters

- 2-1/8"
- Materials: Carbon, Stainless, Aluminum, Galvanized Steel

SIZE	A-MNPT	C	D	F (ID)	F (OD)	PART NO.
2-1/8" x 1-1/4"	1-1/4"	5-3/4"	-	-	2-1/8"	MA-16
2-1/8" x 1-1/2"	1-1/2"	5-3/4"	-	-	2-1/8"	MA-17
2-1/8" x 1-1/4"	1-1/4"	5-3/4"	1-1/4"*	2-1/8"	-	MA-18
2-1/8" x 1-1/2"	1-1/2"	5-3/4"	1-1/4"*	2-1/8"	-	MA-19

* EXPANSION DEPTH

KEY

FNPT = Female National Pipe Thread
OD = Outside Diameter
MNPT = Male National Pipe Thread
ID = Inside Diameter
All reference dimensions are nominal.

When Ordering,
Please Specify
Type of Material:

- Carbon
- Stainless
- Aluminum
- Galvanized Steel

Standard Adapters - cont.

Female and Male Adapter Expanded

- 2" to 6"
- Wall Thickness: 16, 14, 12 Gauge
- Materials: Carbon, Stainless, Aluminum, Galvanized Steel

Female Adapter Expanded

SIZE	GAUGE	A-FNPT	C	D	E (ID)	PART NO.
2" to 2"	16	2"	4"	1-1/8"	2"	FA-203
2" to 2-1/8"	16	2"	4"	1-1/4"	2-1/8"	FA-213
2-1/2" to 2-1/2"	16	2-1/2"	5"	1-1/4"	2-1/2"	FA-253
3" to 3"	16	3"	5-1/4"	1-1/4"	3"	FA-303
3-1/2" to 3-1/2"	16	3-1/2"	5-1/2"	1-1/4"	3-1/2"	FA-353
4" to 4"	16	4"	6-1/2"	1-1/4"	4"	FA-403
5" to 5"	14	5"	6-3/4"	1-1/2"	5"	FA-503
6" to 6"	14	6"	7"	1-1/2"	6"	FA-603

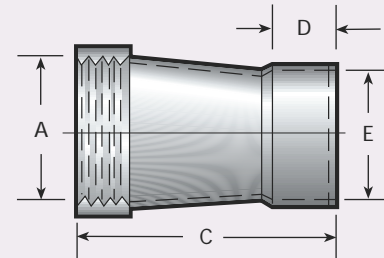

Female Adapter Expanded

Male Adapter Expanded

SIZE	GAUGE	A-MNPT	C	D	E (ID)	PART NO.
2" to 2"	16	2"	4"	1-1/8"	2"	MA-204
2" to 2-1/8"	16	2"	4"	1-1/4"	2-1/8"	MA-214
2-1/2" to 2-1/2"	16	2-1/2"	4"	1-1/4"	2-1/2"	MA-254
3" to 3"	16	3"	4-3/4"	1-1/4"	3"	MA-304
3-1/2" to 3-1/2"	16	3-1/2"	4-3/4"	1-1/4"	3-1/2"	MA-354
4" to 4"	16	4"	4-3/4"	1-1/4"	4"	MA-404
5" to 5"	14	5"	5"	1-1/2"	5"	MA-504
6" to 6"	14	6"	5-1/4"	1-1/2"	6"	MA-604

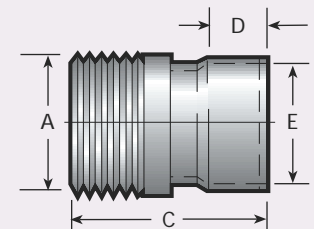

Male Adapter Expanded

90° Adapter Elbow

- 2-1/8" to 2"
- Available only in Cast Gray Iron, Zinc, Nickel Plated or Cast Aluminum

SIZE	C	D	E (ID)	H	L-FNPT	PART NO.
2-1/8" to 2"	2-9/16"	1-1/16"	2-1/8"	1-5/8"	2"	AE-211*

* AVAILABLE ONLY IN CAST GRAY IRON, ZINC, NICKEL PLATED OR CAST ALUMINUM

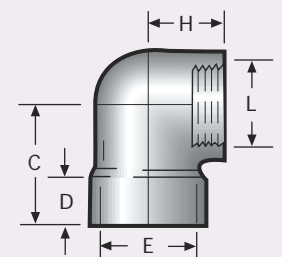

90° Adapter Elbow

Adapter Tees

- 2-1/8" to 4"

• 11 GAUGE ADAPTERS AVAILABLE

SIZE	C	D	E (ID)	H	L-FNPT	PART NO.
2-1/8" to 2"	4-13/16"	1-1/16"	2-1/8"	1-9/16"	2"	AT-212*
2-1/2" to 2"	6-1/2"	1-1/4"	2-1/2"	2-1/8"	2"	AT-250
3" to 2"	6-1/2"	1-1/4"	3"	2-3/4"	2"	AT-302
3-1/2" to 2"	6-7/8"	1-1/4"	3-1/2"	3-7/16"	2"	AT-352
4" to 2"	6-7/8"	1-1/4"	4"	3-7/16"	2"	AT-402

* AVAILABLE ONLY IN CAST GRAY IRON, ZINC, NICKEL PLATED OR CAST ALUMINUM & NOT 11 GAUGE

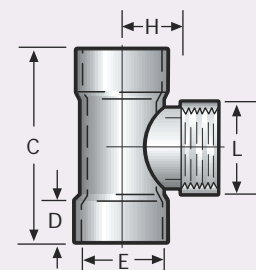

Adapter Tee

KEY

FNPT = Female National Pipe Thread
ID = Inside Diameter
MNPT = Male National Pipe Thread
All reference dimensions are nominal.

Fittings

When Ordering,
Please Specify
Type of Material:

- Carbon
- Stainless
- Aluminum
- Galvanized Steel

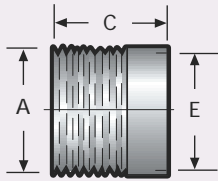

Male Adapter Nipple

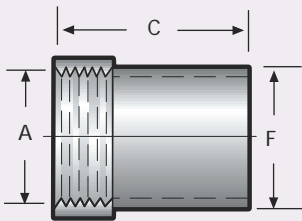

Female Reducing Adapter

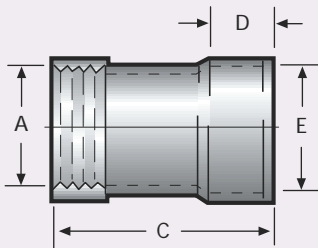

Female Reducing Adapter Expanded

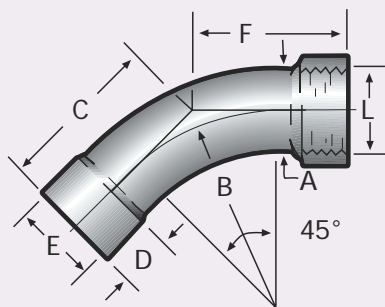

45° Female Adapter Elbow

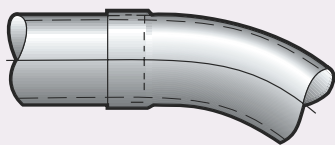

Expanded Fitting

Standard Adapters - cont.

Male Adapter Nipple

- 2-1/8"
- Materials: Carbon, Stainless, Aluminum, Galvanized Steel

SIZE	A-MNPT	C	E (ID)	PART NO.
2-1/8"	2"	2"	2-1/8"	MA-20

Female Reducing Adapter

- 2" to 2-1/2"
- Wall Thickness: 16 Gauge
- Materials: Carbon, Stainless, Aluminum, Galvanized Steel

SIZE	GAUGE	A-FNPT	C	F (OD)	PART NO.
2" to 2-1/2"	16	2"	4-1/4"	2-1/2"	FA-205

Female Reducing Adapter Expanded

- 2" to 2-1/2"
- Wall Thickness: 16 Gauge

SIZE	GAUGE	A-FNPT	C	D	E (ID)	PART NO.
2" to 2-1/2"	16	2"	4-1/4"	1-1/4"	2-1/2"	FA-206

45° Female Adapter Elbow

- 2-1/8" to 2-1/2" OD
- Wall Thickness: 16, (11 Gauge Available in Straight Ends Only)
- Materials: Carbon, Stainless, Aluminum, Galvanized Steel

SIZE	A (OD)	GAUGE	B	C	D	E (ID)	L-FNPT	PART NO.
2-1/8" to 2"	2-1/8"	16	5"	4-1/16"	1-1/4"	2-1/8"	2"	AE-2111
2-1/2" to 2"	2-1/2"	16	6"	4-1/2"	1-1/4"	2-1/2"	2"	AE-2511
2-1/2" to 2-1/2"	2-1/2"	16	6"	4-1/2"	1-1/4"	2-1/2"	2-1/2"	AE-2512

Expanded Fittings

This type of connection enables a straight section of tubing to slip inside the expanded end of the fitting. The two pieces can then be "locked" together by any one of several techniques - brazing, welding, industrial adhesive or shrink sleeve. Not available in 11 gauge material. Joining methods are for use in low pressure (under 15 PSIG) systems. Slotted joining method also available.

KEY

MNPT = Male National Pipe Thread
ID = Inside Diameter
FNPT = Female National Pipe Thread
OD = Outside Diameter
All reference dimensions are nominal.

When Ordering, Please Specify Type of Material:

- Carbon
- Stainless
- Aluminum
- Galvanized Steel

Slip Couplings

Can be used for joining any two straight ends of tubing or fittings. The slip coupling is a solid sleeve that fits the OD of the joint which can then be glued, brazed, welded, or covered by a shrink sleeve.

- 2-1/8" through 14" OD
- Wall Thickness: 16, 14, 12 Gauge
- Materials: Carbon, Stainless, Aluminum, Galvanized Steel

• SLOTTED JOINING METHOD ALSO AVAILABLE

SIZE	C	ID	GAUGE	PART NO.
2-1/8"	3"	2-1/8"	16	SC-213
2-1/2"	3-1/2"	2-1/2"	16	SC-253
3"	4"	3"	16	SC-303
3-1/2"	4-1/2"	3-1/2"	16	SC-353
4"	5"	4"	16	SC-403
5"	6"	5"	14	SC-503
6"	7"	6"	14	SC-603*
8"	8"	8"	14	SC-803
10"	10"	10"	12	SC-1003
12"	12"	12"	12	SC-1203
14"	14"	14"	12	SC-1403

• JOINING METHODS ARE FOR USE IN LOW PRESSURE (UNDER 15 PSIG) SYSTEMS
 * 6" GALVANIZED SLIP COUPLING IS 16 GAUGE. ALL OTHER MATERIALS ARE 14 GAUGE

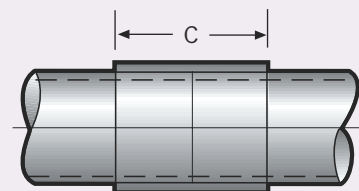

Slip Coupling

Shrink Sleeves

A heat shrinkable polyolefin band that literally shrinks and encircles the connection giving it mechanical strength and a positive seal. It can be used in conjunction with a slip coupling or when using expanded fittings. Gluing, brazing and welding operations are eliminated.

• SLOTTED JOINING METHOD ALSO AVAILABLE

FOR TUBE OD SIZE	SLEEVE LENGTH	PART NO.
2" - 2-1/8"	4"	SS-212
2-1/2" - 3"	4"	SS-300
3-1/4"	4"	SS-400
5"	4"	SS-500
6"	4"	SS-600
8"	9"	SS-800
10"	9"	SS-1000
12"	9"	SS-1200

• JOINING METHODS ARE FOR USE IN LOW PRESSURE (UNDER 15 PSIG) SYSTEMS

Wrapped Sleeve

This kit contains a sheet of black material 18" wide and a sealing strip. The wrapped sleeve comes in a polyolefin shell with a semi-crystalline adhesive.

WIDTH	TUBE LENGTH	PART NO.
18"	14"	WS-1400

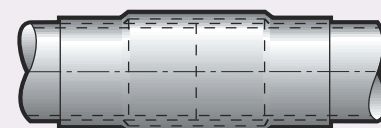

Shrink Sleeve

KEY

OD = Outside Diameter
 ID = Inside Diameter
 PSIG = Pounds per Square Inch Gravity
 All reference dimensions are nominal.

Methods of Joining

When Ordering,
Please Specify
Type of Material:

- Carbon
- Stainless
- Aluminum
- Galvanized Steel



METFLO® Compression Coupling

METFLO® Compression Couplings

"Our own signature coupling"

- Offers easy "tear down" function
- Straight end tubing or fittings butt together within the ID of the coupling, and the joint is mechanically locked simply by tightening the bolts which are attached.
- 2-1/8" to 14" OD
- Standard Material is Galvanized Steel
- Standard Coupling includes Black Neoprene Liner & Stainless Steel Grounding Strip.

- WE ARE CAPABLE OF STAINLESS AND ALUMINUM COMPRESSION COUPLINGS
- OTHER GASKETS ARE AVAILABLE: WHITE NITRILE, RED RUBBER, SILICONE, EPDM AND VITON
- STAINLESS STEEL GASKET PROTECTORS ARE ALSO AVAILABLE
- WE CAN FURNISH YOU WITH REPLACEMENT NUTS, BOLTS, GASKETS AND STATIC STRIPS

OD	NO. BOLT	GASKET	PROTECTOR	COUPLING LENGTH	PART NO.
2-1/8"	2	BLACK	-	4	21252B10
2-1/8"	2	BLACK	YES	4	21252B11
2-1/8"	3	BLACK	-	6	21253B10
2-1/8"	3	BLACK	YES	6	21253B11
2-1/2"	2	BLACK	-	4	25002B10
2-1/2"	2	BLACK	YES	4	25002B11
2-1/2"	3	BLACK	-	6	25003B10
2-1/2"	3	BLACK	YES	6	25003B11
2-1/2"	4	BLACK	-	8	25004B10
2-1/2"	4	BLACK	YES	8	25004B11
3"	2	BLACK	-	4	30002B10
3"	2	BLACK	YES	4	30002B11
3"	3	BLACK	-	6	30003B10
3"	3	BLACK	YES	6	30003B11
3"	4	BLACK	-	8	30004B10
3"	4	BLACK	YES	8	30004B11
3-1/2"	2	BLACK	-	4	35002B10
3-1/2"	2	BLACK	YES	4	35002B11
3-1/2"	3	BLACK	-	6	35003B10
3-1/2"	3	BLACK	YES	6	35003B11
3-1/2"	4	BLACK	-	8	35004B10
3-1/2"	4	BLACK	YES	8	35004B11
4"	2	BLACK	-	4	40002B10
4"	2	BLACK	YES	4	40002B11
4"	3	BLACK	-	4	40003B10
4"	3	BLACK	YES	4	40003B11
4"	4	BLACK	-	8	40004B10
4"	4	BLACK	YES	8	40004B11
5"	2	BLACK	-	4	50002B10
5"	2	BLACK	YES	4	50002B11
5"	3	BLACK	-	6	50003B10
5"	3	BLACK	YES	6	50003B11
5"	4	BLACK	-	8	50004B10

- FOR COUPLINGS 1-1/4" THROUGH 2-7/8" OD THE BOLT SIZE IS 1/2" X 2"
- FOR COUPLINGS 3" THROUGH 7-1/2" OD THE BOLT SIZE IS 5/8" X 2-1/4"
- FOR COUPLINGS 8" THROUGH 14" OD THE BOLT SIZE IS 3/4" X 3"
- JOINING METHODS ARE FOR USE IN LOW PRESSURE (UNDER 15 PSIG) SYSTEMS

KEY

ID = Inside Diameter
OD = Outside Diameter
PSIG = Pounds per Square
Inch Gravity
All reference dimensions
are nominal.

When Ordering,
Please Specify
Type of Material:

- Carbon
- Stainless
- Aluminum
- Galvanized Steel

METFLO® Compression Couplings - cont.

"Our own signature coupling"

- WE ARE CAPABLE OF STAINLESS AND ALUMINUM COMPRESSION COUPLINGS
- OTHER GASKETS ARE AVAILABLE: WHITE NITRILE, RED RUBBER, SILICONE, EPDM AND VITON
- STAINLESS STEEL GASKET PROTECTORS ARE ALSO AVAILABLE
- WE CAN FURNISH YOU WITH REPLACEMENT NUTS, BOLTS, GASKETS AND STATIC STRIPS

OD	NO. BOLT	GASKET	PROTECTOR	COUPLING LENGTH	PART NO.
5"	4	BLACK	YES	8	50004B11
6"	2	BLACK	-	4	60002B10
6"	2	BLACK	YES	4	60002B11
6"	3	BLACK	-	6	60003B10
6"	3	BLACK	YES	6	60003B11
6"	4	BLACK	-	8	60004B10
6"	4	BLACK	YES	8	60004B11
6"	5	BLACK	-	10	60005B10
6"	5	BLACK	YES	10	60005B11
8"	2	BLACK	-	6	80002B10
8"	2	BLACK	YES	6	80002B11
8"	3	BLACK	-	8	80003B10
8"	3	BLACK	YES	8	80003B11
8"	4	BLACK	-	10	80004B10
8"	4	BLACK	YES	10	80004B11
8"	5	BLACK	-	12	80005B10
8"	5	BLACK	YES	12	80005B11
10"	3	BLACK	-	8	100003B10
10"	3	BLACK	YES	8	100003B11
10"	4	BLACK	-	10	100004B10
10"	4	BLACK	YES	10	100004B11
10"	5	BLACK	-	12	100005B10
10"	5	BLACK	YES	12	100005B11
12"	3	BLACK	-	8	120003B10
12"	3	BLACK	YES	8	120003B11
12"	4	BLACK	-	10	120004B10
12"	4	BLACK	YES	10	120004B11
12"	5	BLACK	-	12	120005B10
12"	5	BLACK	YES	12	120005B11
14"	4	BLACK	-	10	140004B10
14"	4	BLACK	YES	10	140004B11
14"	5	BLACK	-	12	140005B10
14"	5	BLACK	YES	12	140005B11

- FOR COUPLINGS 1-1/4" THROUGH 2-7/8" OD THE BOLT SIZE IS 1/2" X 2"
- FOR COUPLINGS 3" THROUGH 7-1/2" OD THE BOLT SIZE IS 5/8" X 2-1/4"
- FOR COUPLINGS 8" THROUGH 14" OD THE BOLT SIZE IS 3/4" X 3"
- JOINING METHODS ARE FOR USE IN LOW PRESSURE (UNDER 15 PSIG) SYSTEMS



METFLO® Compression Coupling

KEY

OD = Outside Diameter
PSIG = Pounds per Square Inch Gravity.
All reference dimensions are nominal.

Methods of Joining

When Ordering,
Please Specify
Type of Material:

- Carbon
- Stainless
- Aluminum
- Galvanized Steel

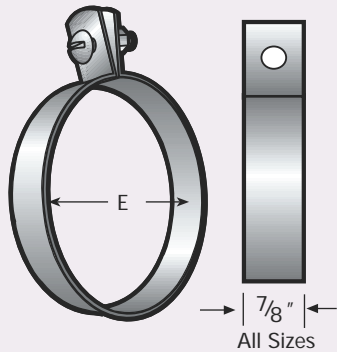

Tube Hanger

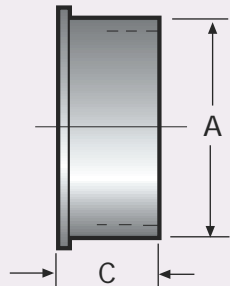

Tube Plug

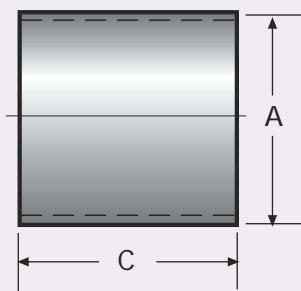

Tube Nipple

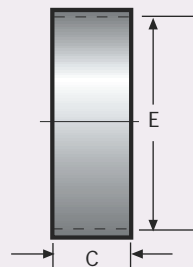

Slip Welding Ring

Cleaner

AMOUNT	PART NO.
Quart	2868

Slip Welding Rings

- 8" to 14" OD
- Materials: Carbon, Stainless, Aluminum, Galvanized Steel

SIZE	C	E (ID)	GAUGE	PART NO.
8"	3"	8"	14	WR-8035
10"	3"	10"	12	WR-10035
12"	3"	12"	12	WR-12035
14"	3"	14"	12	WR-14035

Tube Hangers

- 2-1/8" to 14" ID
- Wall Thickness: 16 gauge
- Available only in Galvanized Steel

SIZE	E (ID)	GAUGE	PART NO.
2-1/8"	2-1/8"	16	TH-212
2-1/2"	2-1/2"	16	TH-250
3"	3"	16	TH-300
3-1/2"	3-1/2"	16	TH-350
4"	4"	16	TH-400
5"	5"	16	TH-500
6"	6"	16	TH-600
8"	8"	16	TH-800
10"	10"	16	TH-1000
12"	12"	16	TH-1200
14"	14"	16	TH-1400

KEY

ID = Inside Diameter
OD = Outside Diameter
All reference dimensions are nominal.

Tube Plugs

- 2-1/8" to 14" OD/ID
- Wall Thickness: 16, 14, 12 Gauge

• AVAILABLE IN 11 GAUGE

SIZE	A (OD)/(ID)	GAUGE	C	PART NO.
2-1/8"	2-1/8" OD	16	1-3/8"	TP-210
2-1/2"	2-1/2" OD	16	1-3/8"	TP-260
3"	3" OD	16	1-3/8"	TP-310
3-1/2"	3-1/2" OD	16	1-3/8"	TP-360
4"	4" OD	16	1-3/8"	TP-410
5"	5" OD	14	1-5/8"	TP-510
6"	6" OD	14	1-5/8"	TP-610
8"	8" ID	14	1-3/4"	TP-810
10"	10" ID	12	2"	TP-1010
12"	12" ID	12	2"	TP-1210
14"	14" ID	12	2"	TP-1410

Tube Nipples

- 2-1/8" to 14" OD
- Wall Thickness: 16, 14, 12 Gauge

• AVAILABLE IN 11 GAUGE

SIZE	A (OD)	GAUGE	C	PART NO.
2-1/8"	2-1/8"	16	2-1/2"	TN-211
2-1/2"	2-1/2"	16	2-1/2"	TN-261
3"	3"	16	2-1/2"	TN-311
3-1/2"	3-1/2"	16	2-1/2"	TN-361
4"	4"	16	2-1/2"	TN-411
5"	5"	14	3"	TN-511
6"	6"	14	3"	TN-611
8"	8"	14	4"	TN-811
10"	10"	12	5"	TN-1011
12"	12"	12	6"	TN-1211
14"	14"	12	7"	TN-1411

When Ordering,
Please Specify
Type of Material:

- Carbon
- Stainless
- Aluminum
- Galvanized Steel

Inlet Valves

Heavy duty inlet valves provide for a quick connection of the male hose coupling to the vacuum cleaning system. These parts are designed for insertion into a 2" FNPT threaded fitting adapting to a 2-1/8" tube size. Valves have self-closing covers and are available in galvanized and stainless steel, as well as nickel plated models. Escutcheon plates allow for a more attractive wall installation.

The same body is used for all three valves...only the bore varies. IV-150 and IV-200 use a slight taper for hose adapter retention. IV-200-CLIP and IV-180 utilize a clip on the valve lid for retention instead. Hose adapters are constructed of heavy-duty galvanized steel.

Inlet Valves

BORE	MNPT	PART NO.
1.5"	2.0"	IV-150
1.8"	2.0"	IV-180
2.0"	2.0"	IV-200
2.0"	2.0"	IV-200-CLIP

Escutcheon Plates

TYPE	PART NO.
Zinc	10253
Stainless	23939
Nickel	25079

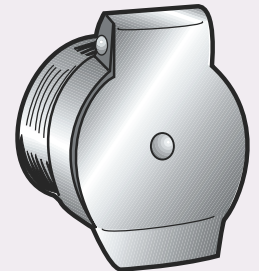

Inlet Valve

(For use with open tubing or when a flush mounting is not required)

Valve Accessories for Installation & Operation

HOSE ADAPTER PART NO.	FOR HOSE SIZE	INLET VALVE PART NO.	WRENCH PART NO.
HA-150	1-1/2" ID	IV-150 accepts 1-1/2" OD Hose Adapter	VW-150
HA-180	1-1/2" ID	IV-180 accepts 1.8" OD Hose Adapter	VW-180
HA-200	2" ID	IV-200 accepts 2" OD Hose Adapter	VW-180
HA-200-RING	2" ID	IV-200-CLIP accepts 2" OD Hose Adapter	VW-180

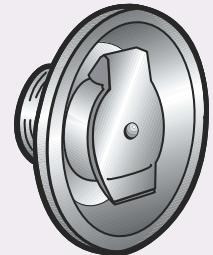

Inlet Valve with escutcheon
(For a flush mounted installation)

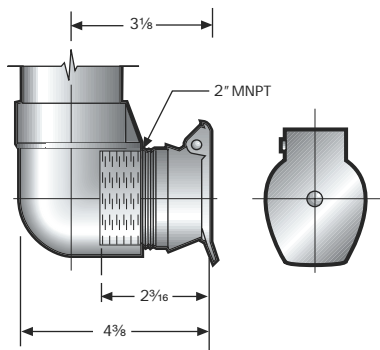

Valve shown in 90° adapter elbow (Part No. AE-211)

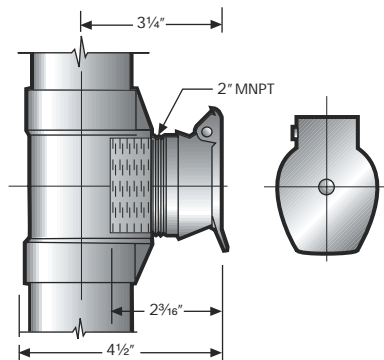

Valve shown in tube fitting (Part No. AT-212)

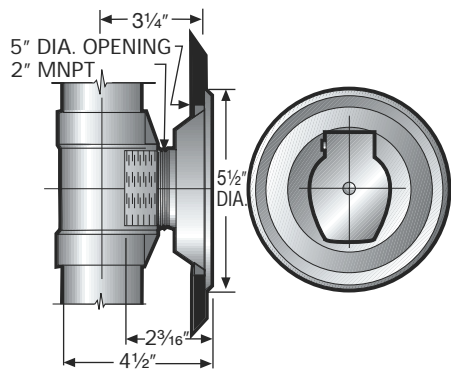

Valve with escutcheon and tee fitting.
Can also be used with 90° adapter elbow

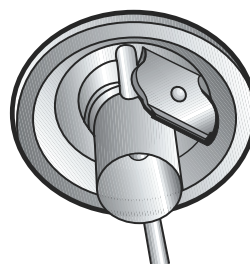

Inlet Valve with escutcheon being tightened into place with installation wrench

KEY FNPT = Female National Pipe Thread
MNPT = Male National Pipe Thread

Floor Valves

Our floor valve is a convenient alternative when wall valves aren't possible. It's built to resist wear and tear, even in heavy traffic areas.

The valve cap is easily removed, but remains flush with the body when not in use. Available in bronze and nickel-plated. Please call customer service for pricing.

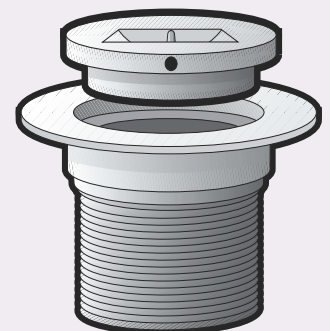

Anchor

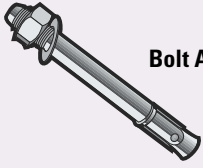

Bolt Anchor

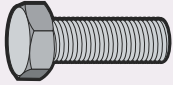

Hex Head Cap Screw
3/8" x 1"

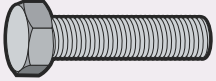

Hex Head Cap Screw
3/8" x 1-1/4"



Hex Nut



Split Lock Washer



Flat Washer

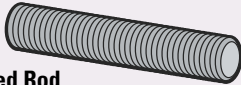

Threaded Rod

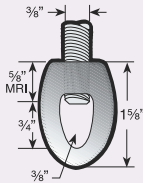

Eye Nut

Coupler Nut

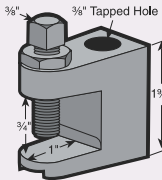
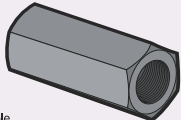

Beam Clamp

Beam Clamp

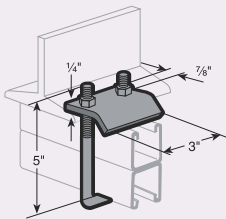

MRI = Minimum Rod Insertion
Zinc = Galvanized
Carbon Steel
OD = Outside Diameter
All reference dimensions are nominal.

KEY

Installation Components

H-P Products, Inc. gives you everything you need to get your system up and running, all in one complete installation package. If you're searching for a particular installation component, we'll be glad to help you find whatever you're looking for. Our "one-stop-shopping" will help you lower your inventory costs and spend less time looking for parts. And, when it's time for installation, you'll have all the components you need on-the-spot.

DESCRIPTION	SIZE	MATERIAL	PKGD.	PART NO.
Anchor , Hilti®	3/8" x 1-9/16" (Length)	Zinc	50 pc.	ANC-0380
Bolt Anchor , Includes Washer and Hex Nut	3/8" x 3-3/4" (Overall Length) 1-1/8" Thread Length	Zinc	100 pc.	ANC-0381
Features: Comprehensive performance testing in concrete, lightweight concrete, and grout-filled block base materials. Can be installed in a bottomless hole. Anchor size is same as hole size for easy installation. Hilti® Kwik Bolt II Stud Anchor System.				
Hex Head Cap Screw	3/8" x 1" (Length)	Zinc	50 pc.	HCS-0380
Hex Head Cap Screw <i>"More Length When You Need It"</i>	3/8" x 1-1/4" (Length)	Zinc	50 pc.	HCS-0381
Hex Nut	3/8"	Zinc	50 pc.	HXN-0380
Flat Washer	3/8"	Zinc	50 pc.	FW-0380
Split Lock Washer	3/8"	Zinc	50 pc.	LKW-0380
Threaded Rod	3/8" x 6' (Length)	Zinc	each	ATR-100
Eye Nut , Maximum Allowable Load is 610 lbs. <i>"Works Great With MetFlo™ Tube Hangers"</i>	3/8" Tapped Hole	Malleable Iron - Plain.	each	EN-0380
Coupler Nut	3/8" x 1-3/4" (Length)	Zinc	each	CN-0380
Beam Clamp with Zinc Set Screw and Lock Nut. Maximum Allowable Load, in top or bottom position, is 550 lbs.	3/8" Tapped Hole	Malleable Iron - Galv.	each	BC-037T
Beam Clamp with Set Screw and Lock Nut. Maximum Allowable Load, in top position, is 500 lbs.; in bottom position, 250 lbs. <i>"The Cost-Effective Solution When You Don't Need Our Heavy-Duty Beam Clamp (BC-037T)"</i>	3/8" Tapped Hole	Malleable Iron - Plain	each	BC-100
Beam Clamp with U-Bolt and 3/8" Hex Nuts included, for use with Beams up to 3/4" Flanges. Design Load is 1000 lbs. Use in pairs only		Zinc	2 pc.	BC-2786

Installation Components - cont.

DESCRIPTION	SIZE	MATERIAL	PKGD.	PART NO.
Channel Nut , without spring	3/8"	Zinc	each	CHN-0380
Saddlenut Assembly <i>"Replaces Square Washer Plate and a Channel Nut Combination"</i>		Zinc	25	SN-0380
Hanger Rod Stiffener Assembly <i>"Adds Rigidity to all Threaded Rod / Strut Channel Combinations where Earthquake Activity is a Concern"</i>		Zinc	each	SA-100
Slotted Strut , 14 Gauge	13/16"(D) x 1-5/8", 10' Length	Zinc	each	UN-100
Slotted Strut , 14 Gauge <i>"An Economical Alternative When You Don't Require Our Heavy-Duty Strut (UN-202)"</i>	1-5/8"(D) x 1-5/8", 10' Length	Zinc	each	UN-201
Slotted Strut , 12 Gauge	1-5/8"(D) x 1-5/8", 10' Length	Zinc	each	UN-202
Strut , 12 Gauge	9/16" Hole Strut 1-5/8"(D) x 1-5/8", 10' Length	Zinc	each	UN-200
90° Strut Bracket	2 x 2, 9/16" Holes	Zinc	each	BRKT-0900
90° Strut Bracket	2 x 1, 9/16" Holes	Zinc	each	BRKT-0901
45° Strut Bracket	9/16" Holes	Zinc	each	BRKT-0450
Square Washer Plate	7/16" Hole for 3/8" Bolt Size	Zinc	100 pc.	SQW-0380
Tube Hanger , includes Bolt and Nut	For 1-1/2" OD Tube	Zinc	each	TH-150
Tube Hanger , includes Bolt and Nut	For 2" OD Tube	Zinc	each	TH-200
Tube Hanger , includes Bolt and Nut	For 2-1/8" and 2-1/4" OD Tube	Zinc	each	TH-212
Tube Hanger , includes Bolt and Nut	For 2-1/2" OD Tube	Zinc	each	TH-250
Tube Hanger , includes Bolt and Nut	For 3" OD Tube	Zinc	each	TH-300
Tube Hanger , includes Bolt and Nut	For 3-1/2" OD Tube	Zinc	each	TH-350
Tube Hanger , includes Bolt and Nut	For 4" OD Tube	Zinc	each	TH-400
Tube Hanger , includes Bolt and Nut	For 4-1/2" OD Tube	Zinc	each	TH-450
Tube Hanger , includes Bolt and Nut	For 5" OD Tube	Zinc	each	TH-500
Tube Hanger , includes Bolt and Nut	For 6" OD Tube	Zinc	each	TH-600
Tube Hanger , includes Bolt and Nut	For 8" OD Tube	Zinc	each	TH-800
Tube Hanger , includes Bolt and Nut	For 10" OD Tube	Zinc	each	TH-1000
Tube Hanger , includes Bolt and Nut	For 12" OD Tube	Zinc	each	TH-1200
Tube Hanger , includes Bolt and Nut	For 14" OD Tube	Zinc	each	TH-1400

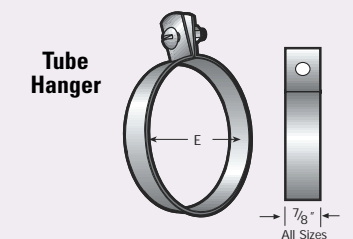
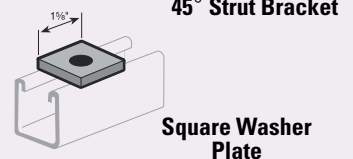
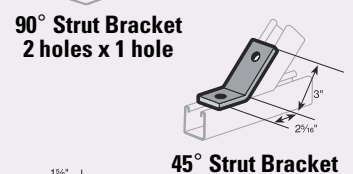
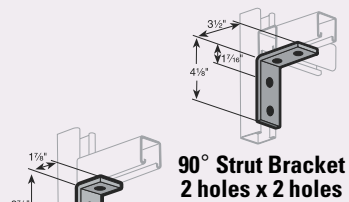
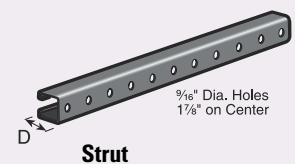
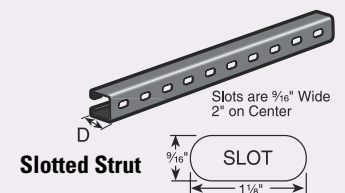
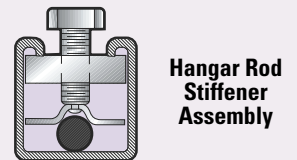
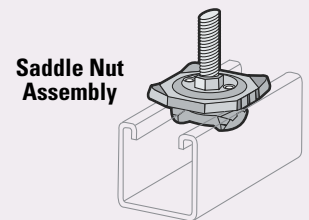
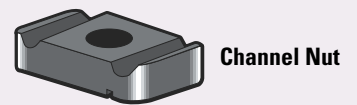

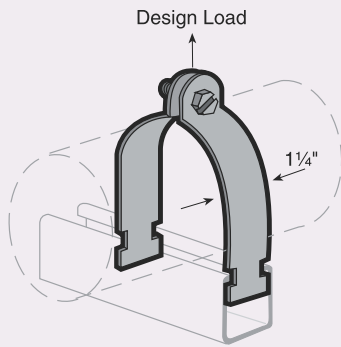

Pipe Clamp

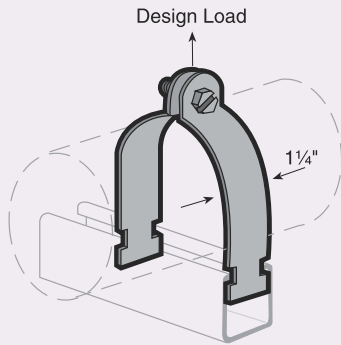

Tube Clamp

Installation Components - cont.

DESCRIPTION	SIZE	MATERIAL	PKGD.	PART NO.
Pipe Clamp , includes Slotted Hex Head Screw and Nut, Design Load 800 lbs.	For 1-1/2" Pipe Size	Zinc	4 pc.	PCL-150
Pipe Clamp , includes Slotted Hex Head Screw and Nut, Design Load 800 lbs.	For 2" Pipe Size	Zinc	4 pc.	PCL-200
Pipe Clamp , includes Slotted Hex Head Screw and Nut, Design Load 800 lbs.	For 2-1/2" Pipe Size	Zinc	4 pc.	PCL-250
Pipe Clamp , includes Slotted Hex Head Screw and Nut, Design Load 800 lbs.	For 3" Pipe Size	Zinc	4 pc.	TCL-350*
Pipe Clamp , includes Slotted Hex Head Screw and Nut, Design Load 1000 lbs.	For 3-1/2" Pipe Size	Zinc	4 pc.	TCL-400*
Pipe Clamp , includes Slotted Hex Head Screw and Nut, Design Load 1000 lbs.	For 4" Pipe Size	Zinc	4 pc.	TCL-450*
Pipe Clamp , includes Slotted Hex Head Screw and Nut, Design Load 1000 lbs.	For 5" Pipe Size	Zinc	4 pc.	PCL-500
Pipe Clamp , includes Slotted Hex Head Screw and Nut, Design Load 1000 lbs.	For 6" Pipe Size	Zinc	4 pc.	PCL-600
Pipe Clamp , includes Slotted Hex Head Screw and Nut, Design Load 1000 lbs.	For 8" Pipe Size	Zinc	4 pc.	PCL-800**
* Tube Clamp also fits this pipe size.				
** 2 piece package				
Tube Clamp , includes Slotted Hex Head Screw and Nut, Design Load 600 lbs.	For 1-1/2" OD Tube	Zinc	4 pc.	TCL-150
Tube Clamp , includes Slotted Hex Head Screw and Nut, Design Load 800 lbs.	For 2" OD Tube	Zinc	4 pc.	TCL-200
Tube Clamp , includes Slotted Hex Head Screw and Nut, Design Load 800 lbs.	For 2-1/8" OD Tube	Zinc	4 pc.	TCL-212
Tube Clamp , includes Slotted Hex Head Screw and Nut, Design Load 800 lbs.	For 2-1/2" OD Tube	Zinc	4 pc.	TCL-250
Tube Clamp , includes Slotted Hex Head Screw and Nut, Design Load 800 lbs.	For 3" OD Tube	Zinc	4 pc.	TCL-300
Tube Clamp , includes Slotted Hex Head Screw and Nut, Design Load 800 lbs.	For 3-1/2" OD Tube	Zinc	4 pc.	TCL-350
Tube Clamp , includes Slotted Hex Head Screw and Nut, Design Load 1000 lbs.	For 4" OD Tube	Zinc	4 pc.	TCL-400
Tube Clamp , includes Slotted Hex Head Screw and Nut, Design Load 1000 lbs.	For 4-1/2" OD Tube	Zinc	4 pc.	TCL-450
Tube Clamp , includes Slotted Hex Head Screw and Nut, Design Load 1000 lbs.	For 5" OD Tube	Zinc	4 pc.	TCL-500
Tube Clamp , includes Slotted Hex Head Screw and Nut, Design Load 1000 lbs.	For 6" OD Tube	Zinc	4 pc.	TCL-600
Tube Clamp , includes Slotted Hex Head Screw and Nut, Design Load 1000 lbs.	For 8" OD Tube	Zinc	4 pc.	TCL-800**
** 2 piece package				

KEY

OD = Outside Diameter
 Zinc = Galvanized
 Carbon Steel
 All reference dimensions
 are nominal.

Installation Components - cont.

DESCRIPTION	SIZE	MATERIAL	PKGD.	PART NO.
Cable Tie Features: One-piece construction. Easy to use. Permanent lock. Designed to withstand 90 lbs. of force. Richco Brand.	23" Length	Nylon	100 pc.	TIE-100
Cable Tie Features: One-piece construction. Easy to use. Permanent lock. Designed to withstand 60 lbs. of force. Catamount Brand. <i>"When Our Heavy-Duty Cable Tie (TIE-100) Isn't Necessary"</i>	24" Length	Nylon	50 pc.	TIE-101
Cable Tie Features: One-piece construction. Easy to use. Permanent lock. Designed to withstand 25 lbs. of force. Catamount Brand. <i>"A Light-Duty, Shorter Length Tie"</i>	14" Length	Nylon	100 pc.	TIE-200

Firestop Sealant

4-gallon Bucket

-

each

FSB-100

A non-sag silicone which remains flexible after curing for simple metal pipe penetrations and fire-rated joints where the ability to absorb movement and/or vibration is required.

Features: Just 1/4" layer provides up to a 3-hour fire rating when backed with 4" of mineral wool. Superior adhesion characteristics. Resistant to smoke and water. Excellent elongation/compression properties. Distributed by Hilti®.

Firestop Sealant

10.5-oz. Tube

-

each

FST-100

Metal Sealant

Quart Can

-

each

2084-QT

An aluminum-colored, medium viscosity, synthetic rubber sealant with excellent adhesion to many metal, glass, wood and other surfaces.

Features: Adheres to metal, wood and glass. Seals metal to glass in windows and doors. Resists weather, water, oil and gasoline. Solids wt. approx. 46%, Flash Point (closed cup) 0° F, heavy liquid consistency, aluminum color (dry), brush or flow application. Drying time is 24 hours (1/8" dia. bead), service temp. range of -30° to 200° F. 3M Scotch-Seal™ 2084 Metal Sealant repackaged by H-P Products, Inc.

Cable Ties

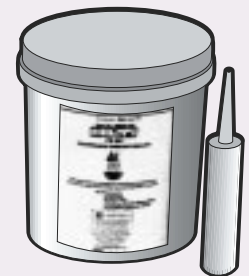
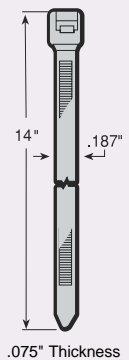
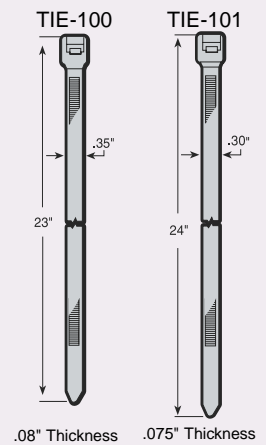

Firestop Sealant



Metal Sealant

"Surface dries tack-free in approx. 5 min."



A division of H-P Products, Inc.

Represented By:
Power Equipment Company
2011 Williamsburg Road
Richmond, VA 23231
Ph: 804-236-3800 Fax: 804-236-3882
www.peconet.com